



SAN FERNANDO CITY COUNCIL
REGULAR MEETING NOTICE AND AGENDA
DECEMBER 7, 2015 – 6:00 PM

COUNCIL CHAMBERS
117 MACNEIL STREET
SAN FERNANDO, CA 91340

CALL TO ORDER/ROLL CALL

Mayor Joel Fajardo
Vice Mayor Sylvia Ballin
Councilmember Robert C. Gonzales
Councilmember Antonio Lopez
Councilmember Jaime Soto

PLEDGE OF ALLEGIANCE

Police Explorer Alfredo Mendoza

APPROVAL OF AGENDA

PRESENTATIONS

- a) PRESENTATION BY CITY OF VERNON MAYOR W. MICHAEL MCCORMICK REGARDING
DONATED VEHICLES
Police Chief Anthony Vairo
- b) PROGRESS UPDATE ON NEW CITY WEBSITE
City Manager Brian Saeki

PUBLIC STATEMENTS – WRITTEN/ORAL

There will be a three (3) minute limitation per each member of the audience who wishes to make comments relating to City Business. Anyone wishing to speak, please fill out the blue

SAN FERNANDO CITY COUNCIL**Regular Meeting Notice and Agenda – December 7, 2015**Page 2 of 6

form located at the Council Chambers entrance and submit it to the City Clerk. When addressing the City Council please speak into the microphone and voluntarily state your name and address.

CONSENT CALENDAR

Items on the Consent Calendar are considered routine and may be disposed of by a single motion to adopt staff recommendation. If the City Council wishes to discuss any item, it should first be removed from the Consent Calendar.

- 1) CONSIDERATION TO ADOPT RESOLUTION NO. 15-121 APPROVING THE WARRANT REGISTER**

- 2) CONSIDERATION TO APPROVE CALENDAR YEAR 2016 BUSINESS LICENSE PERMITS FOR CERTAIN BUSINESS TYPES AS REQUIRED BY THE CITY CODE**

Recommend that the City Council approve 2016 Business License Permits for businesses falling within certain business types, as required by Article III of Chapter 22 of the City Code.

- 3) CONSIDERATION TO ADOPT A RESOLUTION APPROVING DESIGNATED LEVEL I RESERVE POLICE OFFICERS**

Recommend that the City Council adopt Resolution No. 7714 approving Designated Level I Reserve Police Officers.

- 4) CONSIDERATION TO ADOPT RESOLUTIONS AMENDING THE SALARY SCHEDULE AND THE TABLE OF ORGANIZATION FOR FISCAL YEAR (FY) 2015-2016**

Recommend that the City Council:

- a. Adopt Resolution No. 7716 amending the Salary Schedule for FY 2015-2016; and
- b. Adopt Resolution No. 7717 approving the Table of Organization for FY 2015-2016.

- 5) CONSIDERATION TO ADOPT AN ORDINANCE AMENDING THE CITY CODE REGARDING THE APPOINTMENT, REMOVAL, AND RULES OF DECORUM FOR CITY COMMISSIONERS**

Recommend that the City Council waive full reading of Ordinance No. 1648 and adopt by title only, "An Ordinance of the City Council of the City of San Fernando Amending Division

SAN FERNANDO CITY COUNCIL**Regular Meeting Notice and Agenda – December 7, 2015**Page 3 of 6

I (Generally) of Article V (Boards, Commissions, Committees, Agencies, and Authorities) of Chapter 2 (Administration) Regarding the Appointment, Removal, and Rules of Decorum for City Commissioners”

6) RATIFICATION AND RE-APPROVAL OF CITY CLERK EMPLOYMENT AGREEMENT ORIGINALLY APPROVED ON NOVEMBER 16, 2015 SUBJECT TO CERTAIN CLARIFYING AMENDMENTS AND MODIFICATIONS TO MORE PRECISELY EFFECTUATE THE INTENT OF THE PARTIES

Recommend that the City Council:

- a. Ratify and re-approve the City Clerk Employment Agreement (Contract No. 1804) originally approved by the City Council at its meeting of November 16, 2015 subject to certain clarifying amendments and modifications set forth in the updated agreement document; and
- b. Adopt Resolution No. 7718 regarding Public Employee Retirement System, paying and reporting the value of Employer Paid Member Contributions.

7) PREPAREDNESS ACTIVITIES FOR PREDICTED EL NIÑO WINTER STORM EVENTS

Recommend that the City Council receive and file this report.

8) CONSIDERATION TO REPLACE HEATING, VENTILATION AND COOLING SYSTEM (HVAC) EQUIPMENT AT CITY FACILITIES

Recommend that the City Council:

- a. Authorize the City Manager to execute a Purchase Order using the Purchasing Association of Cooperative Entities competitive purchasing agreement with Lennox Industries Inc. for the purchase of HVAC package units, in an amount of \$45,339;
- b. Authorize the City Manager to execute a Services Agreement (Contract No. 1806) using the Purchasing Association of Cooperative Entities competitive purchasing agreement with Comfort Systems USA for the installation and commissioning of HVAC system components, in an amount of \$27,241; and
- c. Establish a contingency of \$11,000 (approximately 15%) for unforeseen conditions associated with this work.

SAN FERNANDO CITY COUNCIL

Regular Meeting Notice and Agenda – December 7, 2015

Page 4 of 6

9) CONSIDERATION TO ADOPT RESOLUTIONS PERTAINING TO THE ADDITION OF PROPERTY ASSESSED CLEAN ENERGY (PACE) FINANCING PROGRAM PROVIDER TO CITY PACE PROGRAM

Recommend that the City Council:

- a. Adopt Resolution Nos. 7719 and 7720, approving membership in the California Home Finance Authority (CHF) and consenting to the inclusion of properties within the City to participate in CHF Community Facilities District No. 2014-1, which will enable property owners to finance permanently fixed renewable energy and water efficiency improvements, and electric vehicle charging infrastructure on their properties; and
- b. Authorize the City Manager to execute any related agreement or documents to facilitate participation in the CHF Property Assessed Clean Energy (PACE) financing programs, which will allow local property owners to participate in this PACE Program.

10) CONSIDERATION TO APPROVE CONSULTANT AGREEMENT AND MEMORANDUM OF UNDERSTANDING RELATED TO STATE OF CALIFORNIA DEPARTMENT OF TRANSPORTATION (CALTRANS) COMMUNITY SUSTAINABLE TRANSPORTATION PLANNING GRANT

Recommend that the City Council:

- a. Adopt Resolution No. 7715, appropriating \$144,200 in grant funding under the Caltrans Sustainable Transportation Planning Grant Program;
- b. Following receipt of a Notice to Proceed from Caltrans related to this grant, confirm the selection of Evans Brooks and Associates for consultant services related to this program (to be funded entirely by grant funding) using the City's existing on-call services agreement (Contract No. 1802 (7 of 16));
- c. Authorize the City Manager or designee to execute a Professional Services Agreement (Contract No. 1807) with the California Center for Public Health Advocacy for outreach services related to this program (to be funded entirely by grant funding); and
- d. Authorize the City Manager or designee to execute a Memorandum of Understanding (MOU) (Contract No. 1808) with the County of Los Angeles Department of Public Health for services related to the preparation of an Active Transportation Program Plan for the City of San Fernando at no cost to the City.

SAN FERNANDO CITY COUNCIL

Regular Meeting Notice and Agenda – December 7, 2015

Page 5 of 6

PUBLIC HEARING**11) CONSIDERATION TO ADOPT AN URGENCY INSTITUTING AN INTERIM MORATORIUM ON THE APPLICATION FILING, PROCESSING, APPROVAL AND ISSUANCE OF PERMITS FOR MULTIPLE-FAMILY DWELLING PROJECTS**

Recommend that the City Council:

- a. Conduct a Public Hearing; and
- b. Pending public testimony, waive full reading and adopt Urgency Ordinance No. U-1649 by title only, "An Urgency Ordinance of the City Council of the City of San Fernando Instituting An Interim Moratorium on the Application Filing, Processing, Approval and Issuance of Permits for Multiple-Family Dwelling Projects." This Ordinance is introduced pursuant to Government Code Section 36937(b) and requires a four-fifths (4/5ths) vote for adoption.

ADMINISTRATIVE REPORTS**12) REVIEW OF TRANSIT SERVICES FOR DEVELOPMENT OF TRANSIT SERVICE PROVIDER REQUEST FOR PROPOSALS (RFP)**

Recommend that the City Council review and provide comments related to key components of the City's Transportation Program.

13) CONSIDERATION TO SUBMIT AN APPLICATION FOR THE FOOD INSECURITY NUTRITION INCENTIVE GRANT PROGRAM AND POTENTIAL IMPLEMENTATION OF A FARMER'S MARKET

This item is placed on the agenda by Mayor Joel Fajardo.

14) DISCUSSION OF PIONEER PARK - PLAY EQUIPMENT UPGRADES AND FENCING

This item is placed on the agenda by Councilmember Jaime Soto.

15) DISCUSSION OF AN APPEAL OF THE PLANNING AND PRESERVATION COMMISSION'S ACTION ON OCTOBER 6, 2015 RELATED TO THE TRANSIT ORIENTED DEVELOPMENT OVERLAY PROJECT

This item is placed on the agenda by Councilmember Jaime Soto.

SAN FERNANDO CITY COUNCIL**Regular Meeting Notice and Agenda – December 7, 2015**Page 6 of 6

COMMITTEE/COMMISSION LIAISON UPDATES**GENERAL COUNCIL COMMENTS****STAFF COMMUNICATION****ADJOURNMENT**

I hereby certify under penalty of perjury under the laws of the State of California that the foregoing agenda was posted on the City Hall bulletin board not less than 72 hours prior to the meeting.

Julie M. Fernandez, Deputy City Clerk

Signed and Posted: December 2, 2015 (2:00 pm)

Agendas and complete Agenda Packets (including staff reports and exhibits related to each item) are posted on the City's Internet Web site (www.sfcity.org). These are also available for public reviewing prior to a meeting in the City Clerk's Office. Any public writings distributed by the City Council to at least a majority of the Councilmembers regarding any item on this regular meeting agenda will also be made available at the City Clerk's Office at City Hall located at 117 Macneil Street, San Fernando, CA, 91340 during normal business hours. In addition, the City may also post such documents on the City's Web Site at www.sfcity.org. In accordance with the Americans with Disabilities Act of 1990, if you require a disability-related modification/accommodation to attend or participate in this meeting, including auxiliary aids or services please call the City Clerk's Office at (818) 898-1204 at least 48 hours prior to the meeting.

Regular Meeting

San Fernando City Council

*This Page
Intentionally
Left Blank*

*This Page
Intentionally
Left Blank*



AGENDA REPORT

To: Mayor Joel Fajardo and Councilmembers

From: Brian Saeki, City Manager
By: Nick Kimball, Finance Director

Date: December 7, 2015

Subject: Consideration to Adopt Resolution No. 15-121 Approving the Warrant Register

RECOMMENDATION:

It is recommended that the City Council adopt Resolution No. 15-121 (Attachment "A") approving the Warrant Register.

BACKGROUND:

For each City Council meeting the Finance Department prepares a Warrant Register for Council approval. The Register includes all recommended payments for the City. Checks, other than handwritten checks, generally are not released until after the Council approves the Register. The exceptions are for early releases to avoid penalties and interest, excessive delays and in all other circumstances favorable to the City to do so. Handwritten checks are those payments required to be issued between Council meetings such as insurance premiums and tax deposits. Staff reviews requests for expenditures for budgetary approval and then prepares a Warrant Register for Council approval and or ratification. Items such as payroll withholding tax deposits do not require budget approval.

The Finance Director hereby certifies that all requests for expenditures have been signed by the department head, or designee, receiving the merchandise or services thereby stating that the items or services have been received and that the resulting expenditure is appropriate. The Finance Director hereby certifies that each warrant has been reviewed for completeness and that sufficient funds are available for payment of the warrant register.

ATTACHMENT:

A. Resolution No. 15-121

ATTACHMENT "A"

RESOLUTION NO. 15-121

RESOLUTION OF THE CITY COUNCIL OF THE CITY OF SAN FERNANDO ALLOWING AND APPROVING FOR PAYMENT DEMANDS PRESENTED ON DEMAND/ WARRANT REGISTER NO. 15-121

THE CITY COUNCIL OF THE CITY OF SAN FERNANDO DOES HEREBY RESOLVE, FIND, DETERMINE AND ORDER AS FOLLOWS:

1. That the demands (EXHIBIT "A") as presented, having been duly audited, for completeness, are hereby allowed and approved for payment in the amounts as shown to designated payees and charged to the appropriate funds as indicated.

2. That the City Clerk shall certify to the adoption of this Resolution and deliver it to the City Treasurer.

PASSED, APPROVED, AND ADOPTED this 7th day of December, 2015.

Joel Fajardo, Mayor

ATTEST:

Elena G. Chávez, City Clerk

STATE OF CALIFORNIA)
COUNTY OF LOS ANGELES) ss
CITY OF SAN FERNANDO)

I HEREBY CERTIFY that the foregoing Resolution was approved and adopted at a regular meeting of the City Council held on the 7th day of December, 2015, by the following vote to wit:

AYES:

NOES:

ABSENT:

Elena G. Chávez, City Clerk

EXHIBIT "A"

vchlist Page: 1
 12/01/2015 1:16:51PM Voucher List
 CITY OF SAN FERNANDO

Bank code : bank

Voucher	Date	Vendor	Invoice	PO #	Description/Account	Amount
112073	12/7/2015	100020 A.G.O.P. SURPLUS STORES	11224		PATCH ORDER 001-222-0000-4300	457.71
			11225		UNIFORMS 001-222-0000-4300	792.68
			11227		UNIFORMS 001-222-0000-4300	468.58
			11229		DISCOUNT 001-222-0000-4300	-20.00
					Total :	1,698.97
112074	12/7/2015	100031 A-1 LAWNMOWER INC.	75328		BELT - PK2364 041-320-0390-4400	52.01
			75375		SPRING & IDLER - PK2364 041-320-0390-4400	64.88
					Total :	116.89
112075	12/7/2015	100101 VERIZON WIRELESS-LA	460851202		PD CELL PHONES 001-222-0000-4220	116.08
			870422920		PD CELL PHONES AND MDT MODEMS 001-222-0000-4220	947.07
			970459610		001-152-0000-4220 VARIOUS CELL PHONES	114.03
					001-105-0000-4220	33.21
					072-360-0000-4220	23.36
					001-101-0109-4220	32.33
					001-101-0111-4220	36.64
					001-101-0107-4220	33.21
					Total :	1,335.93
112076	12/7/2015	100141 ALVAREZ, LINA	321442		SENIOR TRIP REFUND 004-2383	25.00
			321505		SENIOR TRIP REFUND 004-2383	50.00
			321506		SENIOR TRIP REFUND 004-2383	10.00

Page: 1

vchlist Page: 2
 12/01/2015 1:16:51PM Voucher List
 CITY OF SAN FERNANDO

Bank code : bank

Voucher	Date	Vendor	Invoice	PO #	Description/Account	Amount
112076	12/7/2015	100141 100141 ALVAREZ, LINA	(Continued)			Total : 85.00
112077	12/7/2015	100164 AMERICAN PLANNING ASSOCIATION	154054-15104		ANNUAL MEMBERSHIP DUES 001-150-0000-4380	455.00
					Total :	455.00
112078	12/7/2015	100175 AMERICAN WATER WORKS ASSOC.	7001088321		CITY MEMBERSHIP RENEWAL #000344 070-381-0000-4370	420.00
					Total :	420.00
112079	12/7/2015	100222 ARROYO BUILDING MATERIALS, INC	155589		WATER SVC DRIVEWAY APPROACH RE 070-383-0000-4260	135.88
					Total :	135.88
112080	12/7/2015	100311 BARR ELECTRIC CO.	15230		SCADA REMOTE CONTROL OF WELL 4 070-384-0000-4260	748.26
					Total :	748.26
112081	12/7/2015	100466 CACEO	2015RG		CACEO CERTIFICATE 001-152-0000-4370	125.00
					Total :	125.00
112082	12/7/2015	100466 CACEO	200001711		SEMINAR REGISTRATION 001-152-0000-4370	50.00
					Total :	50.00
112083	12/7/2015	100532 STATE OF CALIFORNIA, DEPARTMENT OF JU:	128975		LIVE SCAN FINGERPRINTING - OCT 20 004-2386	3,986.00
			131159		EMPLOYEE SCREENING FINGERPRINT 001-106-0000-4270	32.00
					Total :	4,018.00
112084	12/7/2015	100886 LOS ANGELES DAILY NEWS	0010728716		LEGAL PUBLICATION OF PARKING RAT 001-150-0000-4230	410.20
					Total :	410.20
112085	12/7/2015	101028 TYLER TECHNOLOGIES, INC.	045-147675	11275	FY 15/16-ANNUAL MAINT. OF FINANCIA 072-360-0000-4320	10,367.75

Page: 2

vchlist Voucher List Page: 3
 12/01/2015 1:16:51PM CITY OF SAN FERNANDO

Bank code : bank

Voucher	Date	Vendor	Invoice	PO #	Description/Account	Amount
112085	12/7/2015	101028 TYLER TECHNOLOGIES, INC.	(Continued)	11275	001-135-0000-4260	30,626.57
Total :						40,994.32
112086	12/7/2015	101063 EMPLOYMENT DEVELOPMENT	944-0936-4		07/01/15- 09/30/15 UNEMPLOYMENT IN: 001-190-0420-4132 001-190-0222-4132	213.00 2,579.00
Total :						2,792.00
112087	12/7/2015	101147 FEDEX	5-223-46229 5-231-11077		COURIER SERVICE 001-190-0000-4280 COURIER SERVICE 001-190-0000-4280	59.08 54.61
Total :						113.69
112088	12/7/2015	101273 GARCIA, PATTY	REIMB. REIMB.		MILEAGE REIMB - VARIOUS MEETINGS 001-420-0000-4360 MILEAGE REIMB. - VARIOUS MEETING: 001-420-0000-4360	127.96 10.70
Total :						138.66
112089	12/7/2015	101302 VERIZON	8181811070 8181811075 8181811111 8181811114 8181811126 8181811136 8181811380 8181973210		POLICE PAGING 001-222-0000-4220 CITY HALL PAGING 001-190-0000-4220 MUSIC CHANNEL 001-190-0000-4220 CITY YARD AUTO DIALER 070-384-0000-4220 RADIO REPEATER 001-222-0000-4220 RADIO REPEATER 001-222-0000-4220 MWD METER 070-384-0000-4220 PD MAJOR PHONE LINES 001-222-0000-4220	42.10 42.10 47.51 46.17 46.92 46.92 46.17 1,556.33

Page: 3

vchlist Voucher List Page: 4
 12/01/2015 1:16:51PM CITY OF SAN FERNANDO

Bank code : bank

Voucher	Date	Vendor	Invoice	PO #	Description/Account	Amount
112089	12/7/2015	101302 VERIZON	(Continued) 8181990351 8183610901 8183612385 8183612472 8183613958 8183617825 8188315002 8188371509 8188377174 8188381841 8188384969 8188987385		PAC 50 TO SHERRIFFS 001-222-0000-4220 SEWER FLOW MONITOR 072-360-0000-4220 MTA PHONE LINE 007-440-0441-4220 001-190-0000-4220 PW PHONE LINE 070-384-0000-4220 CNG STATION 041-320-3661-4220 HERITAGE PARK IRRIG. SYSTEM 001-420-0000-4220 PD SPECIAL PROBLEMS 001-222-0000-4220 ANIMAL CONTROL & PW PHONE LINE 001-190-0000-4220 PD SPECIAL PROBLEMS 001-222-0000-4220 ENGINEERING FAX MODEM 001-310-0000-4220 PD ALARM PANEL 001-222-0000-4220 LP FAX LINE 001-420-0000-4220	524.47 54.50 106.80 53.40 279.55 48.34 53.39 48.77 21.02 21.23 27.24 16.80 27.69
Total :						3,157.42
112090	12/7/2015	101376 GRAINGER, INC.	9876342792 9876342800 9879620293 9883048960 9884792293		REPL FLUORESCENT LAMPS 043-390-0000-4300 SMALL TOOLS 043-390-0000-4340 O'RING FOR VALVES - CNG STATION 041-320-3661-4400 BIKEWAY SOLAR LIGHTS FASTENERS 043-390-0000-4300 MISC SPRINGS & PLATES - CNG STATI	95.28 19.46 90.23 63.07

Page: 4

vchlist		Voucher List				Page:	5
12/01/2015 1:16:51PM		CITY OF SAN FERNANDO					
Bank code : bank							
Voucher	Date	Vendor	Invoice	PO #	Description/Account	Amount	
112090	12/7/2015	101376 GRAINGER, INC.	(Continued)				
			9892688079		041-320-3661-4400 VALVE KIT; CNG COMPRESSOR - CNG 041-320-3661-4400	1,175.46 1,786.80	
					Total :	3,230.30	
112091	12/7/2015	101482 HERNANDEZ, JAIME	112115		SENIOR CLUB HOLIDAY DANCE-MUSIC 004-2380	900.00	
					Total :	900.00	
112092	12/7/2015	101528 THE HOME DEPOT CRC, ACCT#603532202490	1614060		WATER HEATER FOR 501 FIRST ST TR, 043-390-0000-4300	356.43	
			173910		SMALL TOOLS, BATTERIES & LP LIGHT 043-390-0000-4300	177.61	
			2564858		SMALL TOOLS - SHOP LIGHTS 041-320-0000-4340	76.15	
			2572439		SIGHT GLASS TUBES - PW1258 072-360-0000-4400	41.39	
			4062022		MAT'LS FOR INSTALLATION OF DOOR (C 043-390-0000-4300	37.33	
			4272030		GALV WIRE, SNIPPERS, STAPLES, STA 011-311-7510-4300	146.95	
			5281894		EXT POLE, FLASHLIGHTS, HEADLAMP; 001-311-0000-4600	146.45	
			5743365		SAFETY GEAR 070-384-0000-4310	78.61	
			6030314		REPLACEMENT OF STOLEN TOOLS & F 070-384-0000-4340	197.24	
			61228		PAINT TO REMOVE GRAFITTI 001-152-0000-4300	41.31	
					Total :	1,299.47	
112093	12/7/2015	101554 HURRICANE FENCE COMPANY	150511		FOOTHILL RES'R FENCE VANDALISM F 070-384-0000-4330	115.00	
					Total :	115.00	
112094	12/7/2015	101647 INTERSTATE BATTERY	30065109		BATTERY FOR FLEET		
							Page: 5

vchlist		Voucher List				Page:	6
12/01/2015 1:16:51PM		CITY OF SAN FERNANDO					
Bank code : bank							
Voucher	Date	Vendor	Invoice	PO #	Description/Account	Amount	
112094	12/7/2015	101647 INTERSTATE BATTERY	(Continued)				
					041-1215	181.72	
					Total :	181.72	
112095	12/7/2015	101666 DE LAGE LANDEN FINANCIAL SERVS	47737215		NOV 2015-LEASE PAYMENT - VARIOUS 001-135-0000-4260	849.08	
					103-420-0000-4260	101.36	
					104-420-0000-4260	101.36	
					070-381-0000-4290	146.70	
			47942002		DEC LEASE PAYMENT - PD COPIERS 001-135-0000-4260	638.12	
					Total :	1,836.62	
112096	12/7/2015	101688 J & R AUDIO	3459		SOUND/TECHNICIANS FOR DIA DE LOS 001-424-0000-4260	1,000.00	
					Total :	1,000.00	
112097	12/7/2015	101772 KING'S BRAKE AND PIONEER TIRE	005790		MOUNT TIRES & ALIGN - WA4573 070-383-0000-4400	135.11	
					Total :	135.11	
112098	12/7/2015	101848 LANGUAGE LINE SERVICES	36973032		TRANSLATION SERVICES 001-222-0000-4260	8.33	
					Total :	8.33	
112099	12/7/2015	101852 LARRY & JOE'S PLUMBING	2661771-0001-02		FAUCET UNDER SINK WATER LINE 043-390-0000-4300	16.70	
					Total :	16.70	
112100	12/7/2015	101920 LIEBERT CASSIDY WHITMORE	1412609		LEGAL SERVICES 001-112-0000-4270	368.50	
			1412610		LEGAL SERVICES 001-112-0000-4270	994.50	
					Total :	1,363.00	
112101	12/7/2015	101929 LINGO INDUSTRIAL ELECTRONICS	32287		TRAFFIC SIGNAL CONTROLLER REPL. 001-371-0301-4300	1,494.39	
			32292		TRAFFIC SIGNAL SOFTWARE REPL.		
							Page: 6

vchlist		Voucher List				Page:	7
12/01/2015 1:16:51PM		CITY OF SAN FERNANDO					
Bank code : bank							
Voucher	Date	Vendor	Invoice	PO #	Description/Account	Amount	
112101	12/7/2015	101929 LINGO INDUSTRIAL ELECTRONICS	(Continued)		001-371-0301-4300		1,417.00
					Total :		2,911.39
112102	12/7/2015	101971 L.A. MUNICIPAL SERVICES	4947501000		WATER - 12900 DRONFIELD	88.44	
			5007501000		ELECTRIC - 13665 FOOTHILL	182.10	
			5947501000		ELECTRIC - 12900 DRONFIELD	5,465.56	
			7577501000		WATER - 14060 SAYRE	105.69	
			7947501000		ELECTRIC - 13186 DRONFIELD	73.30	
					Total :		5,915.09
112103	12/7/2015	101974 LOS ANGELES COUNTY	OCT 2015		DEPT OF ANIMAL CARE & CONTROL F		4,622.03
					001-190-0000-4260		Total : 4,622.03
112104	12/7/2015	101990 L.A. COUNTY METROPOLITAN	800061214		TAP CARDS - JUNE 2015		1,320.00
			800062167		TAP CARDS - OCT 2015		1,180.00
					Total :		2,500.00
112105	12/7/2015	102003 LOS ANGELES COUNTY	RE-PW15100100818	11292	INDUSTRIAL WASTE CHARGES		6,176.28
			RE-PW-15102905079	11292	INDUSTRIAL WASTE CHARGES		2,054.00
			RE-PW-15102905098	11292	INDUSTRIAL WASTE CHARGES		4,957.78
					Total :		13,188.06
112106	12/7/2015	102007 L.A. COUNTY SHERIFFS DEPT.	161480SS		INMATE MEAL SERVICE - OCT 2015		1,146.13
					001-225-0000-4350		Total : 1,146.13

vchlist		Voucher List				Page:	8
12/01/2015 1:16:51PM		CITY OF SAN FERNANDO					
Bank code : bank							
Voucher	Date	Vendor	Invoice	PO #	Description/Account	Amount	
112107	12/7/2015	102051 M & M LANDSCAPE	7088		RES'R 3, 4&5 WEED ABATEMENT & CLE		500.00
					070-384-0000-4260		Total : 500.00
112108	12/7/2015	102148 METROPOLITAN WATER DISTRICT	8517		CAPACITY CHARGE		4,532.50
					070-384-0000-4450		Total : 4,532.50
112109	12/7/2015	102201 MIERZYNSKI, IRMGARD	SEPT-OCT 2015		LINE DANCE INSTRUCTOR		147.00
					017-420-1339-4260		Total : 147.00
112110	12/7/2015	102226 MISSION LINEN & UNIFORM	501247624		LAUNDRY		102.67
			501273802		LAUNDRY		92.58
			501293315		LAUNDRY		110.08
			501318921		LAUNDRY		92.58
			501338319		LAUNDRY		83.92
			501365135		LAUNDRY		92.01
					Total :		573.84
112111	12/7/2015	102307 HI WAY SAFETY RENTALS, INC.	38225		SAFETY VESTS		105.96
					072-360-0000-4310		Total : 105.96
112112	12/7/2015	102423 OCCU-MED, INC.	1015901		PRE-EMPLOYMENT PHYSICALS		467.50
					001-106-0000-4270		Total : 467.50
112113	12/7/2015	102431 THE ODYSSEY RESTAURANT	121715-3		SENIOR CLUB HOLIDAY DINNER-FINAL		5,772.00
					004-2380		Total : 5,772.00

vchlist Voucher List
 12/01/2015 1:16:51PM CITY OF SAN FERNANDO Page: 9

Bank code : bank

Voucher	Date	Vendor	Invoice	PO #	Description/Account	Amount
112114	12/7/2015	102432 OFFICE DEPOT	1855691392		ASCEP SUPPLIES	
					103-420-0000-4300	188.80
			1857010486		104-420-0000-4300	188.80
					HP CARTRIDGES	
			1857043262		001-222-0000-4300	136.24
					RETURNED ITEMS	
			1857400132		001-222-0000-4300	-136.24
					TONER	
			1862320438		001-222-0000-4300	44.74
					ASCEP SUPPLIES	
			1866399362		104-420-0000-4300	125.67
					CERTIFICATE SEALS	
			1867238267		001-101-0000-4300	14.58
					SUPPLIES	
			788449759001		001-222-0000-4300	25.55
					WARRANTY FOR KEYBOARD	
			790941252001		043-390-0000-4300	7.27
					WARRANTY CREDIT FOR RETURNED I	
			803615492001		043-390-0000-4300	-7.27
					CHAIR	
			803615493001		001-420-0000-4300	131.39
					PRINTER	
			803615494001		001-420-0000-4300	208.04
					CABLES	
			803943597001		001-420-0000-4300	5.97
					LASERJET CARTRIDGE	
			803944277001		001-152-0000-4300	185.49
					VOICEMAIL LOG	
			803975854001		001-152-0000-4300	6.01
					CORRECTION TAPE, TAPE & SUPPLIES	
			804043140001		001-222-0000-4300	100.43
					SHREDDER	
			804230426001		001-130-0000-4300	219.69
					SHREDDER RETURNED	
			804542170001		001-130-0000-4300	-219.69
					COPY PAPER	
					001-222-0000-4300	246.31

Page: 9

vchlist Voucher List
 12/01/2015 1:16:51PM CITY OF SAN FERNANDO Page: 10

Bank code : bank

Voucher	Date	Vendor	Invoice	PO #	Description/Account	Amount
112114	12/7/2015	102432 OFFICE DEPOT	(Continued)			
			804665805001		TELEPHONE CORDS	
					001-190-0000-4300	8.21
			804666093001		SIGN HERE FLAGS	
					001-130-0000-4300	11.96
			805368222001		TONERS	
					001-222-0000-4300	347.94
			805373173001		FILE FOLDERS, COPY PAPER AND BRE	
					070-384-0000-4300	328.58
			805373206001		BREAKROOM SUPPLIES	
					070-384-0000-4300	12.99
			805373207001		WIPES TO CLEAN ELECTRONICS	
					070-384-0000-4300	7.99
			805557140001		CNG STATION SUPPLIES	
					041-320-3661-4400	155.25
			806239400001		OFFICE SUPPLIES	
					001-115-0000-4300	48.67
			806239834001		OFFICE SUPPLIES	
					001-115-0000-4300	9.40
					Total :	2,402.77
112115	12/7/2015	102443 OKAFOR, MICHAEL	REIMB.		MILEAGE REIMB - EMPLOY. RELATION	
					001-106-0000-4390	34.73
					Total :	34.73
112116	12/7/2015	102472 ORANGE COUNTY SHERIFF'S DEPT.	TRAVEL		POST PLAN II TRAINING IN ANAHEIM O	
					001-224-0000-4360	80.00
					Total :	80.00
112117	12/7/2015	102506 PANTOJA, DANITZA	NOV 2015		COMMISSIONER'S REIMBURSEMENT	
					001-105-0000-4111	50.00
					Total :	50.00
112118	12/7/2015	102530 AT & T	818-270-2203		ISDN LINE/LASN NETWORK	
					001-222-0000-4220	129.99
					Total :	129.99

Page: 10

vchlist		Voucher List				Page:	11
12/01/2015 1:16:51PM		CITY OF SAN FERNANDO					
Bank code : bank							
Voucher	Date	Vendor	Invoice	PO #	Description/Account	Amount	
112119	12/7/2015	102623 PIONEER FIRE PROTECTION, INC.	328069		FIRE EXTINGUISHER REFILLS - PD0000 041-320-0225-4400	234.97	
					Total :	234.97	
112120	12/7/2015	102666 PREFERRED DELIVERY SYSTEMS INC	549-130		COURIER SERVICE 001-222-0000-4260	103.00	
					Total :	103.00	
112121	12/7/2015	102688 PROFESSIONAL PRINTING CENTERS	29495		PARKING CITE ENVELOPES 001-222-0000-4300	568.31	
					Total :	568.31	
112122	12/7/2015	102738 QUINTERO ESCAMILLA, VIOLETA	NOV 2015		SENIOR MUSIC INSTRUCTOR 017-420-1323-4260	240.00	
					Total :	240.00	
112123	12/7/2015	102779 RAMIREZ, THOMAS	NOV 2015		KARATE INSTRUCTOR 017-420-1326-4260	540.00	
					Total :	540.00	
112124	12/7/2015	102929 ROYAL PAPER CORPORATION	4553152		CANLINERS FOR ALL FACILITIES 043-390-0000-4300	512.46	
			4553935		CANLINERS RETURNED 043-390-0000-4300	-624.15	
			4555274		JANITORIAL SUPPLIES 043-390-0000-4300	394.20	
					Total :	282.51	
112125	12/7/2015	102930 ROYAL WHOLESALE ELECTRIC	8901-721586		STREET LIGHT LAMP REPLACEMENTS 027-344-0301-4300	400.58	
					Total :	400.58	
112126	12/7/2015	102978 SWRCB FEES	LW-1001779		LARGE WATER SYSTEM FEES 070-381-0000-4450	4,121.44	
					Total :	4,121.44	
112127	12/7/2015	102978 SWRCB FEES	WD-0112431		ANNUAL PERMIT FEE - 07/01/15-06/30/1 070-381-0000-4450	2,088.00	
							Page: 11

vchlist		Voucher List				Page:	12
12/01/2015 1:16:51PM		CITY OF SAN FERNANDO					
Bank code : bank							
Voucher	Date	Vendor	Invoice	PO #	Description/Account	Amount	
112127	12/7/2015	102978 102978 SWRCB FEES	(Continued)				Total : 2,088.00
112128	12/7/2015	103010 SAM'S CLUB DIRECT, #0402465855179	2845		BREAKROOM SUPPLIES 001-222-0000-4300	175.79	
			9677		ASCEP SUPPLIES 104-420-0000-4300	137.82	
					Total :	313.61	
112129	12/7/2015	103029 SAN FERNANDO, CITY OF	16207 - 16244		REIMBURSEMENT TO WORKERS COM 006-1035	14,113.32	
					Total :	14,113.32	
112130	12/7/2015	103057 SAN FERNANDO VALLEY SUN	9422		PUBLICATION OF ORD 1646-U 001-115-0000-4230	450.00	
			9426		PUBLICATION AD FOR PARK MASTER F 001-420-0000-4260	375.00	
			9443		PUBLICAITON OF ORD 1647-U 001-115-0000-4230	493.75	
					Total :	1,318.75	
112131	12/7/2015	103168 SIMPLEXGRINNELL LP	78132714		PD EMERGENCY GENERATOR LIGHT T 043-390-0000-4260	974.74	
					Total :	974.74	
112132	12/7/2015	103170 SIRCHIE FINGER PRINT	0230078-IN		FINGERPRINT POWDER 001-222-0000-4300	103.88	
					Total :	103.88	
112133	12/7/2015	103184 SMART & FINAL	116754		LP CLUB SUPPLIES 004-2380	300.85	
			116865		SNACKS FOR PARK CLEAN-UP VOLUN 001-420-0000-4300	16.76	
			119793		SENIOR CLUB SUPPLIES 004-2346	8.24	
					115-422-3750-4300	131.60	
					Total :	457.45	
112134	12/7/2015	103202 SOUTHERN CALIFORNIA EDISON CO.	2-02-682-7675		ELECTRIC - VARIOUS LOCATIONS (OC		
							Page: 12

vchlist		Voucher List				Page:	13
12/01/2015	1:16:51PM	CITY OF SAN FERNANDO					
Bank code : bank							
Voucher	Date	Vendor	Invoice	PO #	Description/Account	Amount	
112134	12/7/2015	103202 SOUTHERN CALIFORNIA EDISON CO.	(Continued)		043-390-0000-4210	5,319.85	
					Total :	5,319.85	
112135	12/7/2015	103205 THE GAS COMPANY	02132069002		GAS- 300 PARK 09/04/15-10/06/15 001-430-0000-4210	2,580.69	
					Total :	2,580.69	
112136	12/7/2015	103205 THE GAS COMPANY	0906206400		GAS - 120 MACNEIL (10/06/15-11/03/15) 070-381-0000-4210 072-360-0000-4210 043-390-0000-4210	3.69 3.69 7.38	
					Total :	14.76	
112137	12/7/2015	103206 SOUTHERN CALIFORNIA GAS CO.	176-827-9753		NATURAL GAS FOR CNG STATION 041-320-3661-4402	4,124.45	
					Total :	4,124.45	
112138	12/7/2015	103251 STANLEY PEST CONTROL	766390 771330		PEST CONTROL @ PD 043-390-0000-4260 PEST CONTROL @ PD 043-390-0000-4260	94.00 94.00	
					Total :	188.00	
112139	12/7/2015	103258 STERIS CORPORATION	5918594		CAL STAT HAND SANITIZER 001-222-0000-4300	529.44	
					Total :	529.44	
112140	12/7/2015	103318 TAG/AMS, INC.	2695605		RANDOM DRUG TESTING 001-106-0000-4270	405.50	
					Total :	405.50	
112141	12/7/2015	103349 THE HOUSE OF PRINTING, INC.	151349		#10 WINDOW ENVELOPES - FINANCE 001-130-0000-4300	382.59	
					Total :	382.59	
112142	12/7/2015	103439 UPS	831954405		COURIER SERVICE 001-190-0000-4280	156.64	
Page: 13							

vchlist		Voucher List				Page:	14
12/01/2015	1:16:51PM	CITY OF SAN FERNANDO					
Bank code : bank							
Voucher	Date	Vendor	Invoice	PO #	Description/Account	Amount	
112142	12/7/2015	103439 103439 UPS	(Continued)			156.64	
					Total :	156.64	
112143	12/7/2015	103444 ULTRA GREENS, INC	56362 56364		COMPOST FOR MACLAY PLANTER 011-311-7510-4300 COMPOST FOR MALL PLANTERS 001-341-0301-4300	43.60 65.40	
					Total :	109.00	
112144	12/7/2015	103449 USA BLUE BOOK	788224		WIKA PRESSURE GAUGE - HUIBBARD 070-384-0301-4300	302.98	
					Total :	302.98	
112145	12/7/2015	103458 U.S. HEALTHWORKS MEDICAL GROUP	2802966-CA		DOT EXAM/COLLECTIONS 001-106-0000-4270	129.00	
					Total :	129.00	
112146	12/7/2015	103463 U.S. POSTMASTER	DEMAND		PRESORTED FIRST CLASS POSTAGE - 070-382-0000-4300 072-360-0000-4300	638.68 638.67	
					Total :	1,277.35	
112147	12/7/2015	103503 UNITED STATES POSTAL SERVICE	15122187		REIMBURSEMENT OF POSTAGE MACH 001-190-0000-4280	1,500.00	
					Total :	1,500.00	
112148	12/7/2015	103619 CARL WARREN & CO.	1720177		LEGAL SERVICES 006-190-0000-4800	375.00	
					Total :	375.00	
112149	12/7/2015	103814 CERVANTES, JORGE	TRAVEL		POST PLAN II TRAINING IN ANAHEIM O 001-224-0000-4360	225.00	
					Total :	225.00	
112150	12/7/2015	103903 TIME WARNER CABLE	8448200540028882 8448200540196309 8448200540222204		CABLE - 11/13-12/12 001-420-0000-4260 INTERNET SERVICES - 11/23/15-12/22/1 001-190-0000-4220 CABLE-120 MACNEIL~	173.22 1,100.00	
Page: 14							

vchlist		Voucher List				Page:	15	
12/01/2015	1:16:51PM	CITY OF SAN FERNANDO						
Bank code :		bank						
Voucher	Date	Vendor	Invoice	PO #	Description/Account	Amount		
112150	12/7/2015	103903 TIME WARNER CABLE	(Continued)		043-390-0000-4260	182.55		
					Total :	1,455.77		
112151	12/7/2015	887296 ROBLEDO, OLIVIA	NOV 2015		COMMISSIONER'S REIMBURSEMENT 001-105-0000-4111	50.00		
					Total :	50.00		
112152	12/7/2015	887366 PIONEER MANUFACTURING COMPANY	INV579793		FIELD LINE SPRAYER & PAINT 017-420-1328-4300	757.56		
					Total :	757.56		
112153	12/7/2015	887454 MCCROMETER, INC.	467445RI		WELL 7A FLOWCOM W/4-20MA 070-384-0301-4300	284.02		
					Total :	284.02		
112154	12/7/2015	887568 TRANS TECH	011383		R&R TRANS REBUILD - PD4985 041-320-0225-4400	1,174.87		
					Total :	1,174.87		
112155	12/7/2015	887570 SIMPLOT PARTNERS	205031708		FIRE ANT BAIT & WEED KILLER 043-390-0000-4300	844.76		
					Total :	844.76		
112156	12/7/2015	887695 AL'S KUBOTA TRACTOR	52040		FRONT ROLLER & DISCHARGE TUBE - 041-320-0390-4400	83.72		
					Total :	83.72		
112157	12/7/2015	887810 CALGROVE RENTALS, INC.	60407		TRENCHING FOR SCADA CONDUIT @ 070-384-0000-4260	117.00		
					Total :	117.00		
112158	12/7/2015	888035 PACIFICA HOSPITL OF THE VALLEY	DR# 13-2246		BLOOD DRAW FOR DR#13-2246 001-224-0000-4270	35.00		
			DR# 14-1158		POST BOOKING MEDICAL EXAM FOR [E] 001-224-0000-4270	75.00		
					Total :	110.00		
						Page:	15	

vchlist		Voucher List				Page:	16	
12/01/2015	1:16:51PM	CITY OF SAN FERNANDO						
Bank code :		bank						
Voucher	Date	Vendor	Invoice	PO #	Description/Account	Amount		
112159	12/7/2015	888195 LEXIPOL LLC	15053		LAW ENFORCEMENT MANUAL FOR PD 001-222-0000-4260	2,850.00		
					Total :	2,850.00		
112160	12/7/2015	888204 ARREGUI, LULU	110515		BILINGUAL TESTING SERVICES 001-106-0000-4270	1,175.00		
					Total :	1,175.00		
112161	12/7/2015	888242 MCI COMM SERVICE	7DL39365		1100 PICO - ALARM LINE 001-420-0000-4220	27.47		
					Total :	27.47		
112162	12/7/2015	888254 MCCALLA COMPANY	41273		GLOVES 001-222-0000-4300	593.62		
					Total :	593.62		
112163	12/7/2015	888264 MISSION VALLEY SANITATION	131025		PORTABLE TOILET RENTAL @ 12900 D 043-390-0000-4260	139.96		
					Total :	139.96		
112164	12/7/2015	888356 ADVANCED AUTO REPAIR BODY &	1290		FUEL PUMP & ECU - PD4985 041-320-0225-4400	721.12		
			1291		REPLACE P/S GEAR BOX - WA4573 070-383-0000-4400	530.69		
			1292		REPLACE RIGHT REAR WINDOW REGI 041-320-0222-4400	164.79		
					Total :	1,416.60		
112165	12/7/2015	888390 WEST COAST ARBORISTS, INC.	110074		TREE TRIMMING SERVICES 011-311-0000-4260	1,849.15		
			110075	11253	TREE TRIMMING SERVICES 011-311-0000-4260	119.30		
			110076	11253	TREE TRIMMING SERVICES 011-311-0000-4260	1,491.25		
			110376	11253	TREE TRIMMING SERVICES 011-311-0000-4260	8,783.85		
			110410	11253	TREE TRIMMING SERVICES			
						Page:	16	

vchlist		Voucher List				Page:	17	
12/01/2015	1:16:51PM	CITY OF SAN FERNANDO						
Bank code :		bank						
Voucher	Date	Vendor	Invoice	PO #	Description/Account	Amount		
112165	12/7/2015	888390 WEST COAST ARBORISTS, INC.	(Continued)	11253	011-311-0000-4260			
					Total :	8,589.60	20,833.15	
112166	12/7/2015	888442 WESTERN EXTERMINATOR COMPANY	3620036		PEST CONTROL @ REC PARK	75.50		
			3620044		043-390-0000-4260	53.00		
			3620046		PEST CONTROL @ RUDY ORTEGA PAF	52.00		
			3641986		043-390-0000-4260	82.50		
					PEST CONTROL @ LP PARK			
					043-390-0000-4260			
					PEST CONTROL @ CITY HALL			
					043-390-0000-4260			
					Total :	263.00		
112167	12/7/2015	888443 BAVCO	735521		LEAD FREE 1/4" M X SAE TESTCOCK	113.82		
					070-383-0301-4300			
					Total :	113.82		
112168	12/7/2015	888468 MAJOR METROPOLITAN SECURITY	1074146		ALARM MONITORING - DEC 2015	15.00		
			1074147		043-390-0000-4260	15.00		
			1074148		ALARM MONITORING - DEC 2015	15.00		
			1074149		043-390-0000-4260	15.00		
			1074150		ALARM MONITORING - DEC 2015	15.00		
			1074151		070-381-0450-4260	15.00		
			1074152		ALARM MONITORING - DEC 2015	15.00		
			1074153		043-390-0000-4260	15.00		
			1074154		ALARM MONITORING - DEC 2015	15.00		
			1074155		043-390-0000-4260	15.00		
					ALARM MONITORING - DEC 2015			
						Page:	17	

vchlist		Voucher List				Page:	18	
12/01/2015	1:16:51PM	CITY OF SAN FERNANDO						
Bank code :		bank						
Voucher	Date	Vendor	Invoice	PO #	Description/Account	Amount		
112168	12/7/2015	888468 MAJOR METROPOLITAN SECURITY	(Continued)		043-390-0000-4260	15.00		
			1074156		ALARM MONITORING - DEC 2015	15.00		
			1074157		043-390-0000-4260	23.00		
			1074158		ALARM MONITORING - DEC 2015	23.00		
			1074159		070-384-0000-4260	23.00		
					ALARM MONITORING - DEC 2015			
					070-384-0000-4260			
					Total :	234.00		
112169	12/7/2015	888646 HD SUPPLY WATER WORKS, LTD	E537591		PARTS FOR NEW WATER SERVICE INS	2,164.27		
			E539229		070-385-0000-4500	-86.66		
			E699649		CREDIT - RETURNED METER BOXES &	552.64		
			E705259		070-383-0301-4300	1,861.15		
			E737026		CONCRETE METER BOXES, LIDS, REA	10.89		
			E742520		070-383-0301-4300	160.10		
					6" 18-TPI RECIPROCATING 5-PK BOSH			
					070-383-0301-4300			
					CONCRETE METER BOX COVERS W/R			
					070-383-0301-4300			
					Total :	4,662.39		
112170	12/7/2015	888682 ZOBEL-RODRIGUEZ, ANGELIQUE Y.	NOV 2015		COMMISSIONER'S REIMBURSEMENT	50.00		
					001-105-0000-4111			
					Total :	50.00		
112171	12/7/2015	888800 BUSINESS CARD	110415		ICA LUNCH MEETING	27.37		
			110415		001-150-0000-4370	27.37		
			110515		001-101-0111-4370	623.93		
					POLICE OFFICER GEAR	-72.69		
					001-222-0000-4300			
					CREDIT - HEADSET RETURNED			
					001-105-0000-4300			
						Page:	18	

vchlist Page: 19
 12/01/2015 1:16:51PM Voucher List
 CITY OF SAN FERNANDO

Bank code : bank

Voucher	Date	Vendor	Invoice	PO #	Description/Account	Amount
112171	12/7/2015	888800 BUSINESS CARD	(Continued) 110515		PARTS FOR THINK ELECTRONIC VEH 041-320-0000-4400	140.00
			110515		PARTS FOR THINK ELECTRONIC VEH 041-320-0000-4400	15.18
			110515		REPLACEMENT CHAIRS FOR IT ROOM 001-135-0000-4300	197.08
			111015		2015 LAUREL AWARDS - REGISTRATIO 001-101-0109-4370	125.00
			111215		WEB HOSTING - NOV 2015 001-190-0000-4260	169.00
			111315		HIGH-SPEED RAIL MEETING - LODGIN 001-101-0101-4370	140.12
			111315		LGBT LEADERS 2015 CONFERENCE - 001-101-0103-4370	295.00
			111315		SECURITY FOR RCS WEBSITE 001-420-0000-4260	100.00
			111315		TRIP GENERATION MANUAL 001-310-0000-4300	560.00
			111615		LGBT LEADERS 2015 CONF - AIRFARE 001-101-0103-4370	397.96
			111615		POST MANAGEMENT TRAINING 001-225-0000-4360	644.04
			111715		DINNER - SPECIAL CITY COUNCIL MEE 001-101-0000-4300	44.30
			111815		LGBT LEADERS 2015 CONF - LODGING 001-101-0103-4370	456.96
			111815		LGBT LEADERS 2015 CONF - LODGING 001-101-0103-4370	228.48
			111915		CIF - LUNCH FOR CHALK ARTISTS 053-101-0103-4430	321.55
			111915		YOUTH VOLUNTEER TRIP TICKETS 017-420-1399-4300	1,985.00
			112315		CONFERENCE PHONES 001-190-0000-4300	1,039.47
			112315		AD - RECRUITMENT OF REC SUPERVIS 001-106-0000-4230	75.00

Page: 19

vchlist Page: 20
 12/01/2015 1:16:51PM Voucher List
 CITY OF SAN FERNANDO

Bank code : bank

Voucher	Date	Vendor	Invoice	PO #	Description/Account	Amount
112171	12/7/2015	888800 888800 BUSINESS CARD	(Continued)			Total : 7,540.12
112172	12/7/2015	889037 AT&T MOBILITY	875587443		MODEM FOR MESSAGE BOARD 001-310-0000-4220	64.50 Total : 64.50
112173	12/7/2015	889043 ALADIN JUMPERS	102215		ITEMS RENTED FOR 5K EVENT 001-424-0000-4260	975.00 Total : 975.00
112174	12/7/2015	889118 LDI COLOR TOOLBOX	1021320		COPIES & MAINT CONTRACT 001-222-0000-4260	212.82
			1021514		COPIES & MAINT CONTRACT 001-222-0000-4260	458.37 Total : 671.19
112175	12/7/2015	889274 BOWDEN MORENO, LINDA	REIMB.		MILEAGE REIMB. 001-420-0000-4370	39.10 Total : 39.10
112176	12/7/2015	889328 FIRST TRANSIT, INC.	1152854	11282	CITY TRANSIT AND CITY TROLLEYS - C 007-440-0442-4260	43,047.84 Total : 43,047.84
112177	12/7/2015	889352 GOMEZ, ADRIANA	NOV 2015		COMMISSIONER'S REIMBURSEMENT 001-420-0000-4111	50.00 Total : 50.00
112178	12/7/2015	889457 NATIONAL METER & AUTOMATION	S1066189.001	11289	2" WATER METERS 070-385-0700-4500 070-385-0700-4500	15,100.00 1,434.50 Total : 16,534.50
112179	12/7/2015	889467 YOUNGBLOOD & ASSOCIATES	1921A		POLYGRAPH EXAM 001-222-0000-4260	200.00 Total : 200.00
112180	12/7/2015	889491 WILLDAN FINANCIAL SERVICES	010-29198		2015-16 LANDSCAPING & LIGHTING AS	

Page: 20

vchlist		Voucher List				Page: 21	
12/01/2015 1:16:51PM		CITY OF SAN FERNANDO					
Bank code : bank							
Voucher	Date	Vendor	Invoice	PO #	Description/Account		Amount
112180	12/7/2015	889491 WILLDAN FINANCIAL SERVICES	(Continued)	11210	027-344-0000-4260	Total :	2,505.00
							2,505.00
112181	12/7/2015	889503 JTB SUPPLY COMPANY, INC.	100060		PED MODULE TRAFFIC SIGNAL REPL 001-371-0301-4300	Total :	565.02
							565.02
112182	12/7/2015	889532 GILMORE, REVA.A.	10/31/15 - 11/13/15		FOOD SERVICE MANAGER 115-422-3750-4270		653.25
			11/14/15 - 11/27/15		FOOD SERVICE MANAGER 115-422-3752-4270		91.00
					FOOD SERVICE MANAGER 115-422-3750-4270		494.00
					FOOD SERVICE MANAGER 115-422-3752-4270	Total :	65.00
							1,303.25
112183	12/7/2015	889533 MARTINEZ, ANITA	10/31/15 - 11/13/15		FOOD SERVICE INTAKE CLERK 115-422-3750-4270		180.00
			11/14/15 - 11/27/15		FOOD SERVICE INTAKE CLERK 115-422-3750-4270	Total :	126.00
							306.00
112184	12/7/2015	889535 GOMEZ, GILBERT	10/31/15 - 11/13/15		HDM DRIVER 115-422-3752-4270		162.00
			11/14/15 - 11/27/15		HDM DRIVER 115-422-3752-4390		46.80
					HDM DRIVER 115-422-3752-4270		126.00
					HDM DRIVER 115-422-3752-4390	Total :	36.40
							371.20
112185	12/7/2015	889545 PEREZ, MARIBEL	REIMB.		MILEAGE REIMB - ENP TRAINING & CP 001-420-0000-4360	Total :	182.85
							182.85
112186	12/7/2015	889611 MORRISON MANAGEMENT SPECIALIST	18845201510310118		LP SENIOR MEALS - OCT 2015 115-422-3750-4260		4,815.00
					115-422-3752-4260		2,731.50
							Page: 21

vchlist		Voucher List				Page: 22	
12/01/2015 1:16:51PM		CITY OF SAN FERNANDO					
Bank code : bank							
Voucher	Date	Vendor	Invoice	PO #	Description/Account		Amount
112186	12/7/2015	889611 MORRISON MANAGEMENT SPECIALIST	(Continued)			Total :	7,546.50
							7,546.50
112187	12/7/2015	889626 ASSETWORKS, INC	MA15-677		ANNUAL RENEWAL FEE FOR ASSTEM# 001-135-0000-4260	Total :	1,400.00
							1,400.00
112188	12/7/2015	889627 VERIZON CONFERENCING	Z5594044		CONFERENCE CALLS - SEPT & OCT 20 001-190-0000-4220	Total :	17.69
							17.69
112189	12/7/2015	889644 VERIZON BUSINESS	61589830		CITY HALL LONG DISTANCE 001-190-0000-4220		48.58
			61589833		POLICE LONG DISTANCE 001-222-0000-4220		83.73
			61589834		CITY YARD LONG DISTANCE 070-384-0000-4220		9.71
			61589835		PARK LONG DISTANCE 001-420-0000-4220		14.92
			61590385		ENGINEERING LONG DISTANCE 001-310-0000-4220		4.87
			61590398		CITY HALL LINES 001-190-0000-4220		55.60
			61590399		CITY YARD LONG DISTANCE 070-384-0000-4220	Total :	14.56
							231.97
112190	12/7/2015	889681 VILLALPANDO, MARIA	10/31/15 - 11/13/15		FOOD SERVICE WORKER 115-422-3750-4270		202.50
			11/14/15 - 11/27/15		FOOD SERVICE WORKER 115-422-3752-4270		40.50
					FOOD SERVICE WORKER 115-422-3750-4270		189.00
					FOOD SERVICE WORKER 115-422-3752-4270	Total :	36.00
							468.00
112191	12/7/2015	889942 ATHENS SERVICES	1511199		STREET SWEEPING SERVICES - NOV 2 001-343-0000-4260		1,995.44
				11251	011-311-0000-4260		10,629.56
							Page: 22

vchlist		Voucher List				Page:	23	
12/01/2015	1:16:51PM	CITY OF SAN FERNANDO						
Bank code :		bank						
Voucher	Date	Vendor	Invoice	PO #	Description/Account	Amount		
112191	12/7/2015	889942 889942 ATHENS SERVICES	(Continued)			Total :	12,625.00	
112192	12/7/2015	889978 PERFORMANCE PIPELINE	7961	11233	CITY SEWER SYSTEM TVING 072-360-0000-4260	Total :	64,801.94 64,801.94	
112193	12/7/2015	890004 PACIFIC TELEMAGEMENT SERVICE	793036		PD PAY PHONE - DEC 2015 001-190-0000-4220	Total :	62.64 62.64	
112194	12/7/2015	890095 O'REILLY AUTO PARTS	4605-164186 4605-165817 4605-167726 4605-167865		SMALL TOOLS 041-320-0000-4340 TUBING CUTTER - PD2302 041-320-0225-4400 TURN SIGNAL SWITCH - PK4464 041-320-0390-4400 INSIDE DOOR HANDLE - PK8230 041-320-0390-4400	Total :	218.99 7.65 35.54 16.72 278.90	
112195	12/7/2015	890242 SAFEWAY SIGN COMPANY	4138		ASSORTED STREET SWEEPING SIGN I 001-370-0301-4300	Total :	493.54 493.54	
112196	12/7/2015	890360 HERRERA, NINAMARIE JULIA	NOV 2015		COMMISSIONER'S REIMBURSEMENT 001-420-0000-4111	Total :	50.00 50.00	
112197	12/7/2015	890411 ARC DOCUMENT SOLUTIONS, LLC	8335864		COPIES OF SEWER MAP 001-310-0000-4300	Total :	28.27 28.27	
112198	12/7/2015	890463 KJC LATENT PRINT SERVICE	SF00026		FINGERPRINT CLASSIFICATIONS 001-222-0000-4260	Total :	100.00 100.00	
112199	12/7/2015	890534 WHENTOWORK, INC.	60694185-30-12-15		ONLINE SCHEDULING SERVICE 001-420-0000-4260	Total :	200.00	
							Page:	23

vchlist		Voucher List				Page:	24	
12/01/2015	1:16:51PM	CITY OF SAN FERNANDO						
Bank code :		bank						
Voucher	Date	Vendor	Invoice	PO #	Description/Account	Amount		
112199	12/7/2015	890534 890534 WHENTOWORK, INC.	(Continued)			Total :	200.00	
112200	12/7/2015	890594 HEALTH AND HUMAN RESOURCE	131852		EAP - DEC 2015 001-106-0000-4260	Total :	235.30 235.30	
112201	12/7/2015	890833 THOMSON REUTERS	832817503		LA CLEAR - INVEST TOOL 001-224-0000-4270	Total :	165.96 165.96	
112202	12/7/2015	890834 SPARKLING IMAGE CORP	64778		CAR WASHES - OCT 2015 001-222-0000-4320	Total :	140.00 140.00	
112203	12/7/2015	890838 BLUE TARP FINANCIAL	34024595 34032570 34039035		NO FLAT, TIRES (WHEEL BARROW) - PI 041-320-0390-4400 TRUCK RACK - ME4412 041-320-0320-4400 ENGINE FOR PRESSURE WASHER - P 041-320-0311-4400	Total :	101.96 196.38 1,742.29 2,040.63	
112204	12/7/2015	890879 EUROFINS EATON ANALYTICAL, INC	L0223263A L0240386 L0240392 L0240603 L0240607 L0240608 L0240613 L0240614		CREDITED TWICE ON FOLDER 541939 070-384-0000-4260 WATER ANALYSIS - F560280 070-384-0000-4260 WATER ANALYSIS - F560885 070-384-0000-4260 WATER ANALYSIS - F558961 070-384-0000-4260 WATER ANALYSIS - F560609 070-384-0000-4260 WATER ANALYSIS - F560610 070-384-0000-4260 WATER ANALYSIS - F561418 070-384-0000-4260 WATER ANALYSIS - F561667	Total :	129.20 139.60 139.60 900.00 80.00 139.60 139.60	
							Page:	24

vchlist		Voucher List				Page:	25
12/01/2015	1:16:51PM	CITY OF SAN FERNANDO					
Bank code : bank							
Voucher	Date	Vendor	Invoice	PO #	Description/Account	Amount	
112204	12/7/2015	890879 EUROFINS EATON ANALYTICAL, INC	(Continued)				
			L0240842		070-384-0000-4260 WATER ANALYSIS - F562019 070-384-0000-4260	139.60 139.60 Total : 1,946.80	
112205	12/7/2015	890897 EVAN BROOKS ASSOCIATES, INC	150010-14	11277	CONTRACT PLANNER SERVICERS 001-150-0000-4270	3,180.00	
			150011-10	11229	ENG DESIGN SERVICES FOR SAFE RC 010-370-3636-4600	2,400.00 Total : 5,580.00	
112206	12/7/2015	890970 WEX BANK	42771750		FUEL FOR CITY FLEET 041-320-0152-4402 041-320-0221-4402 041-320-0222-4402 041-320-0224-4402 041-320-0225-4402 041-320-0226-4402 041-320-0228-4402 041-320-0311-4402 041-320-0312-4402 041-320-0320-4402 041-320-0346-4402 041-320-0370-4402 041-320-0371-4402 041-320-0390-4402 041-320-0420-4402 007-313-3630-4402 027-344-0000-4402 029-335-0000-4402 070-381-0000-4402 070-383-0000-4402 070-384-0000-4402 072-360-0000-4402 070-382-0000-4402	517.04 192.47 214.06 581.66 3,490.93 18.68 515.39 1,054.51 2.00 195.67 4.00 385.17 189.20 1,002.21 4.00 1,871.38 124.76 448.49 39.19 1,373.53 281.19 533.34 198.49	
						Page:	25

vchlist		Voucher List				Page:	26
12/01/2015	1:16:51PM	CITY OF SAN FERNANDO					
Bank code : bank							
Voucher	Date	Vendor	Invoice	PO #	Description/Account	Amount	
112206	12/7/2015	890970 890970 WEX BANK	(Continued)			Total : 13,237.36	
112207	12/7/2015	890994 PONCE, JOE	NOV 2015		COMMISSIONER'S REIMBURSEMENT 001-420-0000-4111	50.00 Total : 50.00	
112208	12/7/2015	891054 MEJIA, YVONNE G	NOV 2015		COMMISSIONER'S REIMBURSEMENT 001-105-0000-4111	50.00 Total : 50.00	
112209	12/7/2015	891121 RIVERA, NICOLE	OCT 2015		MMAP MENTOR INSTRUCTOR 109-424-3637-4260	240.00 Total : 240.00	
112210	12/7/2015	891209 AUTONATION SSC	209613		DOOR LOCK SWITCH - PD3030 041-320-0225-4400	39.04 Total : 39.04	
112211	12/7/2015	891253 SAN FERNANDO SMOG TEST ONLY	3971		SMOG TEST - 1079883 041-320-0000-4260	50.00 Total : 50.00	
112212	12/7/2015	891311 TORRES, RITA	10/31/15 - 11/13/15 11/14/15 - 11/27/15		ENP SUBSTITUTE 115-422-3750-4270 ENP SUBSTITUTE 115-422-3750-4270 115-422-3752-4270	47.25 200.25 9.00 Total : 256.50	
112213	12/7/2015	891329 MIKE'S TIRE MAN INC	0045719		FRONT TIRES - WA4573 070-383-0000-4400	314.08 Total : 314.08	
112214	12/7/2015	891344 P & E PROMOTIONS	3238		SAFETY VESTS REPLACEMENTS 029-335-0301-4300	222.36 Total : 222.36	
112215	12/7/2015	891377 REYES, JOSE	10/31/15 - 11/13/15		HDM DRIVER		
						Page:	26

vchlist		Voucher List				Page:	27	
12/01/2015	1:16:51PM	CITY OF SAN FERNANDO						
Bank code :		bank						
Voucher	Date	Vendor	Invoice	PO #	Description/Account	Amount		
112215	12/7/2015	891377 REYES, JOSE	(Continued)		115-422-3752-4270	162.00		
			11/14/15 - 11/27/15		115-422-3752-4390	56.16		
					HDM DRIVER			
					115-422-3752-4270	144.00		
					115-422-3752-4390	49.92		
					Total :	412.08		
112216	12/7/2015	891502 BLUE VIOLET NETWORKS LLC	6350	11092	TELECOM AUDIT SERVICES			
					001-190-0000-4220	2,500.00		
					Total :	2,500.00		
112217	12/7/2015	891531 WILLDAN ENGINEERING	00320513	11285	ST. RESURFACING PRJ. ENGINEERING			
					072-365-0560-4600	9,607.99		
					Total :	9,607.99		
112218	12/7/2015	891542 MR "B" PRINTING INC.	33177		MARKETING MATERIALS			
					001-423-0000-4300	255.06		
					Total :	255.06		
112219	12/7/2015	891571 WESTERN STAMP, INC	35056		(2) CHIEF'S OFFICE STAMPS			
					001-222-0000-4300	92.71		
					Total :	92.71		
112220	12/7/2015	891587 ABLE MAILING INC.	23128		ENVELOPE STORAGE - OCT 2015			
					070-382-0000-4300	12.50		
					072-360-0000-4300	12.50		
			23129	11238	NOV BILLS- FULFILLMENT; FOLD TWO			
				11238	070-382-0000-4300	87.80		
					072-360-0000-4300	87.80		
			23154		FULFILLMENT SERVICE - POSTAGE & I			
					070-382-0000-4300	16.11		
					072-360-0000-4300	16.10		
					Total :	232.81		
112221	12/7/2015	891622 FARMER BROTHERS	62465165		BREAKROOM SUPPLIES			
					001-222-0000-4300	258.85		
							Page: 27	

vchlist		Voucher List				Page:	28	
12/01/2015	1:16:51PM	CITY OF SAN FERNANDO						
Bank code :		bank						
Voucher	Date	Vendor	Invoice	PO #	Description/Account	Amount		
112221	12/7/2015	891622 891622 FARMER BROTHERS	(Continued)				Total : 258.85	
112222	12/7/2015	891711 CHIEF LAW ENFORCEMENT SUPPLY	402172		BULLETPROOF VESTS			
			409568		001-222-0000-4300	1,597.25		
					BULLETPROOF VESTS			
					001-222-0000-4300	1,592.25		
					Total :	3,189.50		
112223	12/7/2015	891739 ALAS MEDIA	201481		FILMING OF TOD MEETING AUG 2015			
					001-150-0000-4270	400.00		
			201511		FILMING OF TOD MEETING - 10/06/15			
					001-150-0000-4270	470.00		
					Total :	870.00		
112224	12/7/2015	891741 L.J. LE BLANC	15-018		ON CALL ENGINEERING SERVICES - O			
					001-310-0000-4270	798.00		
					Total :	798.00		
112225	12/7/2015	891766 RODRIGUEZ, PATRICIA	10/18/15 - 11/21/15		LATIN JAM WORKOUT INSTRUCTOR			
					017-420-1337-4260	100.00		
					Total :	100.00		
112226	12/7/2015	891767 CHAVEZ, ELIZABETH	10/18/15 - 11/21/15		ZUMBA INSTRUCTOR			
					017-420-1337-4260	140.00		
					Total :	140.00		
112227	12/7/2015	891777 IRRIGATION EXPRESS	15030153-00		NITRATE PROJECT PARTS			
			15033241-00		070-384-0301-4300	13.95		
			15033634-00		MAT'LS FOR CITY HALL WATER LEAK F			
					043-390-0000-4300	24.29		
			15033731-00		MAT'LS FOR CITY HALL WATER LEAK F			
					043-390-0000-4300	16.12		
					MAT'LS FOR CITY HALL WATER LEAK F			
					043-390-0000-4300	83.94		
					Total :	138.30		
112228	12/7/2015	891794 KIMBALL, NICK	REIMB.		WELLNESS BENEFIT REIMB. FY15-16			
					001-130-0000-4140	600.00		
							Page: 28	

vchlist		Voucher List				Page:	29
12/01/2015 1:16:51PM		CITY OF SAN FERNANDO					
Bank code : bank							
Voucher	Date	Vendor	Invoice	PO #	Description/Account	Amount	
112228	12/7/2015	891794 891794 KIMBALL, NICK	(Continued)			Total :	600.00
112229	12/7/2015	891841 NAVA STUDIO AND DESIGN	INV.CSF.001-03	11224	LANDSCAPE ARCHITECTURAL/ENG DE 029-335-0000-4600	Total :	10,000.00 10,000.00
112230	12/7/2015	891849 SHI INTERNATIONAL CORP	B04249039	11290	ADOBE ACROBAT PRO 001-420-0000-4300	Total :	365.00 365.00
112231	12/7/2015	891860 CARL WARREN & COMPANY	10026-10040		REIMB. TO ITF ACCT (LIABILITY CLAIM# 006-1037	Total :	16,051.31 16,051.31
112232	12/7/2015	891881 REMENIH, MICHAEL	NOV 2015		COMMISSIONER'S REIMBURSEMENT 001-105-0000-4111	Total :	50.00 50.00
112233	12/7/2015	891885 GANIR-MARTINEZ, ARLENE	10/18/15 - 11/21/15		YOGA INSTRUCTOR 017-420-1337-4260	Total :	40.00 40.00
112234	12/7/2015	891896 A CLASSY LIMOSINE SERVICE	4871		SENIOR TRIP- TRANSPORTATION 004-2384	Total :	450.00 450.00
112235	12/7/2015	891902 P.F. SERVICES INC.	11836		REGULATOR REPAIR - CNG STATION 041-320-3661-4400	Total :	542.52 542.52
112236	12/7/2015	891905 OLIMPIO, SONIA	10/18/15 - 11/21/15		ZUMBA INSTRUCTOR 017-420-1337-4260	Total :	140.00 140.00
112237	12/7/2015	891969 ADVANCED PURE WATER SOLUTIONS	36495711-1215		DRINKING WATER 001-222-0000-4300	Total :	102.33 102.33
							Page: 29

vchlist		Voucher List				Page:	30
12/01/2015 1:16:51PM		CITY OF SAN FERNANDO					
Bank code : bank							
Voucher	Date	Vendor	Invoice	PO #	Description/Account	Amount	
112238	12/7/2015	891990 SEVERN TRENT DE NORA, LLC	1130127	11281	WELL 4A ELECTROLYTIC CELL ASSEMI 041-320-0000-4320 041-320-0000-4320	Total :	419.58 4,306.47 4,726.05
112239	12/7/2015	891993 HERNANDEZ, ALBINO	10/18/15 - 11/21/15		TOTAL BODY CONDITIONING & CYCLIN 017-420-1337-4260	Total :	140.00 140.00
112240	12/7/2015	892001 SPORTABLE SCOREBOARDS	INV-0106925	11271	SCOREBOARDS 017-420-1328-4300	Total :	10,879.23 10,879.23
112241	12/7/2015	892010 SOTO JR., JAIME	111215 NOV - DEC 2015		GENERAL MAINTENANCE 001-424-0000-4260 FIELD PREP 017-420-1328-4260	Total :	30.00 350.00 380.00
112242	12/7/2015	892023 PAETEC	5726123		PHONE SERVICE 11/18-12/17 001-222-0000-4220 001-420-0000-4220 070-384-0000-4220 001-190-0000-4220	Total :	765.49 1,091.56 498.05 491.02 2,846.12
112243	12/7/2015	892026 KTB CONSTRUCTION	NO. 3	11283 11283	BRAND BLVD WATERWISE LANDSCAPI 032-311-0178-4600 070-385-0178-4600 032-2037 070-2037	Total :	9,900.00 27,141.88 -990.00 -2,714.19 33,337.69
112244	12/7/2015	892032 KUHFUSS, DESIREE	10/18/15 - 11/21/15		MAT PILATES INSTRUCTOR 017-420-1337-4260	Total :	100.00 100.00
112245	12/7/2015	892033 A PANORAMA FLOWERS	111815		LP CLUB - PLANTS & FUNERAL WREAT		
							Page: 30

vchlist		Voucher List				Page:	31	
12/01/2015 1:16:51PM		CITY OF SAN FERNANDO						
Bank code :		bank						
Voucher	Date	Vendor	Invoice	PO #	Description/Account		Amount	
112245	12/7/2015	892033 A PANORAMA FLOWERS	(Continued)		004-2380		459.93	
						Total :	459.93	
112246	12/7/2015	892059 COMMERCIAL VEHICLE	1035		BIT INSPECTION CONSULTING FEE 072-360-0000-4260		500.00	
						Total :	500.00	
112247	12/7/2015	892060 JCL TRAFFIC	81372		EQUIPMENT RENTAL FOR 5K EVENT 001-420-0000-4260		247.25	
						Total :	247.25	
112248	12/7/2015	892061 LOPEZ, SHERLINE	103115		HONORARIUM FOR NATIONAL ANTHEM 004-2359		100.00	
						Total :	100.00	
112249	12/7/2015	892062 KEENE MUSIC SERVICES, LLC	112315		HOLIDAY CAROLERS FOR TREE LIGHT 001-424-0000-4260		525.00	
						Total :	525.00	
112250	12/7/2015	892063 MARTINEZ, BERNANDO	321475		SENIOR TRIP REFUND 004-2384		20.00	
						Total :	20.00	
112251	12/7/2015	892064 GALVAN, JUANITA	321443		SENIOR TRIP REFUND 004-2383		25.00	
						Total :	25.00	
112252	12/7/2015	892065 GITTINS, SILVA	321498		SENIOR CLUB TRIP REFUND 004-2383		5.00	
			757363		SENIOR CLUB TRIP 004-2384		50.00	
						Total :	55.00	
112253	12/7/2015	892066 PACHECO, HORTENCIA	110315		SENIOR CLUB THANKSGIVING DANCE 004-2380		900.00	
						Total :	900.00	
						Page:	31	

vchlist		Voucher List				Page:	32	
12/01/2015 1:16:51PM		CITY OF SAN FERNANDO						
Bank code :		bank						
Voucher	Date	Vendor	Invoice	PO #	Description/Account		Amount	
112254	12/7/2015	892067 RIVERA, ALMA	2000213.001		FACILITY RENTAL REFUND 001-3777-0000		70.00	
						Total :	70.00	
112255	12/7/2015	892068 PEREZ, CAROLINA	2000212.001		FACILITY RENTAL REFUND 001-3777-0000		225.00	
						Total :	225.00	
112256	12/7/2015	892069 GOVEA, RALPH	2000214.001		FACILITY RENTAL REFUND 001-3777-0000		520.00	
						Total :	520.00	
112257	12/7/2015	892070 HOLD FAST PRODUCTIONS, LLC	PFP2015-12.2		FILMING REFUND - UNDERSTAFFED H 001-3715-0000		490.00	
						Total :	490.00	
112258	12/7/2015	892071 ROBLES, J.	REIMB.		REIMB OF UNIFORM PURCHASED 001-222-0000-4300		204.81	
						Total :	204.81	
112259	12/7/2015	892072 HARO, YOLANDA	NOV 2015		COMMISSIONER'S REIMBURSEMENT 001-420-0000-4111		50.00	
						Total :	50.00	
187 Vouchers for bank code :		bank				Bank total :	483,643.57	
187 Vouchers in this report						Total vouchers :	483,643.57	
Voucher Registers are not final until approved by Council.								
						Page:	32	

*This Page
Intentionally
Left Blank*



AGENDA REPORT

To: Mayor Joel Fajardo and Councilmembers

From: Brian Saeki, City Manager
By: Nick Kimball, Finance Director

Date: December 7, 2015

Subject: Consideration to Approve Calendar Year 2016 Business License Permits for Certain Business Types as Required by the City Code

RECOMMENDATION:

It is recommended that the City Council approve 2016 Business License Permits for businesses falling within certain business types (Attachment "A"), as required by Article III of Chapter 22 of the City Code.

BACKGROUND:

1. On August 31, 2015, Business License Permit Renewal Applications for calendar year 2016 were mailed to certain businesses that fall within certain business types that require City Council approval per Article III of Chapter 22 of the City Code. The applications were due on September 30, 2015.
2. On October 26, 2015, all completed applications received by the Finance Department were submitted to the Community Development Department for review of zoning and building requirements. All applications were subsequently approved.
3. On November 5, 2015, all completed applications received by the Finance Department and approved by the Community Development Department were submitted to the Police Department for approval. All applications were approved.
4. On November 10, 2015, all completed applications received by the Finance Department and approved by the Community Development and Police Departments were submitted to the Public Works Department for review and approval. All applications requiring their approval were approved.

Consideration to Approve Calendar Year 2016 Business License Permits for Certain Business Types as Required by the City CodePage 2 of 4

ANALYSIS:

Article III of Chapter 22 of the San Fernando City Code (SFCC) requires certain types of businesses (see Section 22-215) to obtain a Business License Permit in addition to their regular Business License. Business License Permits require the approval of the City Council.

Each affected business must file an application, in writing, specifying where the business is proposed to operate. Once approved, the permit is valid for the calendar year, or a shorter period of time as may be prescribed by any resolution of the City Council or in the permit.

Applications are submitted to the Finance Department and reviewed by the Police, Community Development and Public Works departments for compliance with all applicable regulations. Completed applications are on file in the Finance Department.

If the Business License Permits are approved, they will automatically expire on December 31, 2016. After the expiration date, applicants will be required to submit a renewal for the upcoming calendar year.

BUDGET IMPACT:

The Business License Permit fees previously adopted by the City Council ensure the administrative costs associated with said application are recovered by the City.

CONCLUSION:

By approving the permits for the businesses noted on the attached list, the City Council permits the businesses included as Attachment "A" to continue their operations for calendar year 2016 at the specified commercial addresses.

ATTACHMENTS:

- A. List of Business License Permit Applicants for Calendar Year 2016

ATTACHMENT "A"**BUSINESS LICENSE PERMIT APPLICANTS BY CATEGORY (Section 22-215):****AUTOMOBILE DEALERS (USED)**

Western Motor Sports
Valley Auto Sales
Isaac's Auto Sales
Rydell Chrysler Dodge Jeep Ram
Ganas Auto Group (formerly Tricolor)
Diego's Auto Sales

BINGO

San Fernando Elks #1539
St. Ferdinand Catholic Church

DANCING

El Potro Bar

DANCING ACADEMY

Fox Studio of Dance
Royalty Dance Academy
Danzone

FORTUNE TELLERS

Botanica Santa Barbara

MASSAGE

QQ Spa
Vida Spa

MISCELLANEOUS

Orange Grove Mobile Home Park
San Fernando Swap Meet

PEDDLERS

Garcia Produce

BUSINESS LICENSE PERMIT APPLICANTS BY CATEGORY (Section 22-215) CONTINUED:

POOL TABLES

El Potro Bar

PRIVATE PATROL / SECURITY

Security Specialists / Tyan Inc

REFUSE DISPOSAL

Consolidated Disposal Service, LLC

SECOND-HAND MERCHANDISE

Cassell's Music

Goodyear Tire Center

Addax Inc

LE-TAC

SECOND-HAND JEWELRY (PAWNSHOP)

San Fernando Loan Company

TAXICAB BUSINESS

Yellow Cab Company

*This Page
Intentionally
Left Blank*



AGENDA REPORT

To: Mayor Joel Fajardo and Councilmembers

From: Brian Saeki, City Manager
By: Anthony Vairo, Police Chief

Date: December 7, 2015

Subject: Consideration to Adopt Resolution No. 7714 Approving Designated Level I Reserve Police Officers

RECOMMENDATION:

It is recommended that the City Council adopt Resolution No. 7714 (Attachment "A") approving Designated Level I Reserve Police Officers.

BACKGROUND/ANALYSIS:

The San Fernando Police Department currently has 10 non-designated Level I Reserve Police Officers. These Reserve Police Officers supplement our full-time sworn Police Officer staff by working patrol, court commitment, detectives, transportation of prisoners, special events, emergency call-outs, as well as to cover for our regular Police Officers during peak periods or as needed. Our Reserve Police Officers fulfill a vital need and help keep San Fernando a safe community.

California Penal Code Section 830.6 provides that if a person is appointed as a Reserve Police Officer, the person is a peace officer provided he or she meets the requirements of Penal Code Section 832.6. Penal Code Section 832.6 specifies three levels of Reserve Police Officers: Levels I, II and III. At issue herein is the classification of Level I Reserve Police Officer, which is the closest to regular Police Officers in terms of the amount of training required. Level I Reserve Police Officers are assigned to the prevention and detection of crime and the general enforcement of the laws of California (typically known as "patrol" but encompassing the full array of law enforcement activities), and do not require supervision.

Under the Penal Code Section 830.6(a), there are two classes of Level I Reserve Police Officers: "designated" and "non-designated." Pursuant to Section 830.6(a)(2) of the California Penal Code, whenever any qualified person is deputized or appointed by the proper authority as a Reserve City Police Officer, and is so designated by local ordinance or resolution, either individually or by class, and is assigned to the prevention and detection of crime and the general enforcement of the laws of California by that authority, the person is a peace officer

Consideration to Adopt Resolution No. 7714 Approving Designated Level I Reserve Police OfficersPage 2 of 5

with the legally equivalent status of a Police Officer appointed pursuant to the provisions of Section 830.1 of the California Penal Code (commonly referred to as a “regular” Police Officer).

Non-designated Level I Reserve Police Officers generally have full Police Officer authority only for the duration of their specific assignment (e.g., only while “on-duty”), per Penal Code Section 830.6(a)(1). However, “designated” Level I Reserve Police Officers have full police powers and duties 24 hours per day regardless of whether they are on-duty or not (just as full-time regular sworn Police Officers do), providing they are empowered by the local governing body, either by ordinance or resolution, per Penal Code Section 830.6(a)(2). Many California law enforcement agencies have “designated” their Level I Reserve Police Officers and Reserve Deputy Sheriffs, primarily because Reserve Police Officers and Reserve Deputy Sheriffs with “designated” Level I status are legally authorized to carry out full Police Officer powers 24-hours a day, whereas “non-designate” Level I Reserve Police Officers and Reserve Deputy Sheriffs may only carry out full peace officer powers during the performance of their assigned duties.

Many Reserve Police Officers spend considerable time within their cities and travel to and throughout their cities. Under their current classification, if a violent crime in progress were to occur in their presence, “non-designated” Level I Reserve Police Officers are unable to take police action without incurring personal liability and potentially vicarious liability for the City. Thus, even though fully trained to do so, non-designated Level I Reserve Officers who take off-duty action create potential liability for their agencies and themselves personally without the protections afforded persons with peace officer status when they take such actions. By granting the Police Chief the authority to appoint “designated” Level I Reserve Police Officers, City Council will effectively increase police presence within the City at no additional cost to the City as well as limit potential liability in circumstances where a Level I Reserve Officer takes action off-duty.

Level I Reserve Police Officers have the same training requirements as full-time sworn Police Officers. Both full-time regular Police Officers and Level I Reserve Police Officers must complete a California Commission on Peace Officers Standards and Training (POST) Basic Police Academy and complete the Regular Basic Course. San Fernando Police Department Level I Reserve Police Officers must successfully complete the San Fernando Police Department POST-certified Field Training Program consisting of over 400 hours of field training time. In addition, they have the same continuous professional training (CPT) requirements as full-time Police Officers (minimum of 24 hours every two years).

San Fernando Police Department Reserve Police Officers have become an indispensable commodity to the City. They have provided the City and the Department thousands of hours of work every year. Reserve Police Officers are required to work a minimum of 20 hours per month to remain active in the Reserve Program, and many work well in excess of that amount.

The Resolution provides that, upon appointment by the Chief of Police, a Reserve Police Officer who has qualified as a Level I Reserve Police Officer pursuant to California Penal Code Section

Consideration to Adopt Resolution No. 7714 Approving Designated Level I Reserve Police OfficersPage 3 of 5

832.6(a)(1) and, in addition, has completed a minimum of 400 hours of field training as a Level I Reserve Police Officer, shall be “designated” and have those peace officer powers and duties as provided by Subsection (2) of Subsection (a) of Section 830.6 of the California Penal Code. Such officers shall be known as “Designated Level I Reserve Police Officers.”

Nothing shall prevent the Police Chief from granting, revoking or suspending “Designated Level I Reserve Police Officer” status as to any particular officer, nor shall the Police Chief be under any mandate or obligation to make such a designation.

BUDGET IMPACT:

There is no budget impact to the General Fund.

CONCLUSION:

It is recommended that the City Council adopt Resolution No. 7714 providing the Police Chief with the authority to “designate” Level I Reserve Peace Officers as set forth in detail above. The California Penal Code prescribes the methodology to “designate” Level I Reserve Peace Officer, namely to introduce a Resolution by which the City Council authorizes the Police Chief to “designate” Level I Reserve Police Officers within the meaning of Penal Code Section 830.6(a)(2).

ATTACHMENT:

A. Resolution No. 7714

ATTACHMENT "A"**RESOLUTION NO. 7714****A RESOLUTION OF THE CITY COUNCIL OF THE CITY OF SAN FERNANDO, CALIFORNIA, ADOPTING AND GRANTING DESIGNATED LEVEL I RESERVED POLICE OFFICER STATUS TO QUALIFIED MEMBERS OF THE SAN FERNANDO POLICE DEPARTMENT RESERVE UNIT**

WHEREAS, the City of San Fernando has appointed Level I Reserve Police Officers to work patrol, court commitment, detectives, transportation of prisoners, special events, emergency call-outs, and provide cover to regular Police Officers during peak periods or as needed; and

WHEREAS, California Penal Code Section 830.6(a)(2) provides, among other things, that a municipality may adopt an ordinance or resolution providing for the "designation" of Level I Reserve Police Officers by the Chief of Police, the effect of which results in such designated Level I Reserve Police Officers at all times having the authority of peace officers appointed pursuant to California Penal Code Section 830.1; and

WHEREAS, the City does not currently have an ordinance or resolution which grants the City's Chief of Police the authority to deputize or appoint designated Reserve Police Officers pursuant to Penal Code Sections 830.6 and 832.6; and

WHEREAS, the City has previously adopted the San Fernando Police Department Manual, which contains volume 5-001 entitled "The San Fernando Police Reserve Manual," became effective as of February 17, 2015, is binding upon all Reserve Police Officers, and contains Section 5-004.06 (Deployment of Reserve Police Officers), which describes the different Reserve Police Officers levels as they currently exist in the San Fernando Police Department; and

WHEREAS, it is the goal of the City of San Fernando and the Police Department to provide for the safety of its citizens by increasing police presence (both on-duty and off-duty) and to attract and retain the most qualified Reserve Police Officers to supplement our staff.

NOW, THEREFORE, THE CITY COUNCIL OF THE CITY OF SAN FERNANDO DOES HEREBY RESOLVE, FIND, DETERMINE AND ORDER AS FOLLOWS:

Section 1. The City Council finds that all of the facts set forth in this Resolution are true and correct.

Section 2. The City Council of the City of San Fernando does hereby adopt and grant Designated Level I Reserve Police Officer status to those qualified members of the San Fernando Police Department Reserve Unit, in accordance with California Penal Code Sections 830.6(a)(2), 832.6(a)(1), and 832.6(b).

Section 3. Upon appointment by the Chief of Police, each Level I Reserve Police Officer appointed pursuant to California Penal Code Section 832.6(a)(1), who has completed the basic training course of peace officers and field training prescribed by the Commission of Peace officer Standards and Training (POST), and who is assigned to the prevention and detection of crime and general enforcement of the laws of the State of California, shall be “designated” as set forth in California Penal Code Section 830.6(a)(2) and shall have those peace officer powers and duties as provided therein. Such officers shall be known as “Designated Level I Reserve Police Officers.”

Section 4. Section 5-004.06 (Deployment of Reserve Officers) of the San Fernando Police Reserve Manual is hereby amended to include the above-referenced designation. The revised Section 5-004.06, contained in Exhibit “A,” is incorporated herein by reference, and is hereby added to the San Fernando Police Reserve Manual.

PASSED, APPROVED, AND ADOPTED this 7th day of December, 2015.

Joel Fajardo, Mayor

ATTEST:

Elena G. Chávez, City Clerk

STATE OF CALIFORNIA)
COUNTY OF LOS ANGELES) ss
CITY OF SAN FERNANDO)

I HEREBY CERTIFY that the foregoing Resolution was approved and adopted at a regular meeting of the City Council held on the 7th day of December, 2015, by the following vote to wit:

AYES:

NOES:

ABSENT:

Elena G. Chávez, City Clerk

EXHIBIT "A"

If a reserve officer becomes employed in any prohibited employment, the reserve officer may be subject to termination from the Reserve Division. The Chief of Police retains discretion to apply the foregoing as he or she deems necessary or appropriate in the specific case.

Off-duty employment of reserve officers is only available following completion of probation and subject to approval of the Reserve Staff Commander.

5-004.04 TRAINING REQUIREMENTS

POST sets training standards for all peace officers in California. Prior to appointment to the Department, reserve officers must complete POST-certified instruction (currently as follows): Level I reserve officers must satisfactorily complete the POST Regular Basic Course. Level II Reserve Officers are required to satisfactorily complete the prescribed Level II course of instruction (Modules III and II). Level III reserve officers are required to satisfactorily complete the prescribed Level III training program (Module III). Following appointment, all Level I and Level II reserve officers shall complete the Department's field training requirements.

5-004.05 CONTINUING PROFESSIONAL TRAINING

All reserve officers shall complete 24 hours of Continuing Professional Training (CPT) every 2 years in accordance with POST requirements. Failure to meet CPT requirements may lead to suspension until such time as those requirements are satisfied.

5-004.06 DEPLOYMENT OF RESERVE OFFICERS

The Penal Code prescribes the following reserve officer levels:

- Level I (Designated and Non-Designated)
- Level II
- Level III

The POST Reserve Peace Officer Summary appears at the end of this section. The following summarizes such provisions:

LEVEL I (DESIGNATED AND NON-DESIGNATED) RESERVE OFFICERS

Level I reserve officers perform general law enforcement assignments and are "designated" if the municipality employing them has adopted an ordinance or resolution "designating" such officers as having full peace officer authority both on-duty and off-duty. Non-designated Level I reserve officers have peace officer authority only while

on-duty. Level I reserve officers must successfully complete the Department's POST-approved Field Training Program, following which they may work alone in a general law enforcement capacity.

LEVEL II RESERVE OFFICERS

A Level II reserve officer may perform general law enforcement assignments only while under the immediate supervision of a peace officer who has completed the POST Regular Basic Course. Immediate supervision is defined as continually being in the physical proximity of and available to the reserve officer. However, allowances are permitted for necessary temporary separations such as tactical situations requiring separation. A Level II reserve officer may work assignments authorized for Level III reserve officers without immediate supervision. Level II reserve officers who work patrol assignments must complete the Department's Field Training Program. Level II reserve officers have peace officer powers only while on-duty.

LEVEL III RESERVE OFFICERS

Level III reserve officers may perform limited support duties and other duties which are not likely to result in physical arrests. Level III reserve officers may not be assigned to general law enforcement activities. Level III reserve officers may perform their duties while supervised in the accessible vicinity by an officer who has completed the Regular Basic Course. Level III reserve officers may transport prisoners without immediate supervision. Level III reserve officers have peace officer powers only while on-duty.

POST Reserve Peace Officer Status Summary

APPOINTMENT	AUTHORITY	ASSIGNMENT	SUPERVISION	TRAINING
LEVEL I 830.6(a)(1) PC 832.6(a)(1) PC	24 hours ¹ <u>OR</u> duration of specific assignment (on-duty)	General Law Enforcement ²	Same as regular full-time peace officer (as determined by the agency)	1. Regular Basic Course ³ (min. 664 hours) 2. Field Training Program (min. 400 hours) 3. CPT (24 hours every 2 years)
LEVEL II 830.6(a)(1) PC 832.6(a)(2) PC	Only for duration of specific assignment (on-duty)	General Law Enforcement OR Limited Support Duties: May work assignments authorized for Level III Reserve Officers	Immediate supervision by a peace officer who has completed the POST Regular Basic Course Without immediate supervision	1. Modules III and II (min. 333 hours) 2. CPT (24 hours every 2 years)
LEVEL III 830.6(a)(1) PC 832.6(a)(3) PC	Only for duration of specific assignment (on-duty)	Limited Support Duties Duties not likely to result in physical arrests. Examples: traffic control, security at parades/sporting events, report writing, evidence transportation. May transport prisoners without immediate supervision	Supervised in the accessible vicinity by a Level I Reserve or a regular full-time peace officer	1. Module III (min. 144 hours)

¹Agencies may appoint a Level I Reserve Peace Officer to full 830.1 PC powers and duties (24 hour) by authority of a city resolution or county ordinance (830.6 (a)(2) PC).

²General Law Enforcement: duties which include the investigation of crime, patrol of a geographic area, responding to the full range of requests for police services, and performing any enforcement action on the full range of law violations.

³The POST Regular Basic Course may be completed in an Intensive, Extended or Modular Format.

*This Page
Intentionally
Left Blank*



AGENDA REPORT

To: Mayor Joel Fajardo and Councilmembers

From: Brian Saeki, City Manager
By: Michael E. Okafor, Personnel Manager

Date: December 7, 2015

Subject: Consideration to Adopt Resolutions Amending the Salary Schedule and Table of Organization for Fiscal Year (FY) 2015-2016

RECOMMENDATION:

It is recommended that the City Council:

- a. Adopt Resolution No. 7716 (Attachment "A") amending the Salary Schedule for FY 2015-2016; and
- b. Adopt Resolution No. 7717 (Attachment "B") approving the Table of Organization for FY 2015-2016.

BACKGROUND:

1. On October 8, 2009, the City Council approved an MOU with the San Fernando Public Employees' Association (SFPEA) that includes certain changes in benefits for FY 2009-2010 through FY 2011-2012.
2. On December 7, 2009, the City Council approved an MOU with the San Fernando Management Group (SFMG) that includes certain changes in benefits for FY 2009-2010 through FY 2011-2012.
3. On January 19, 2010, the City Council amended the Salary Plan to include similar benefits for the unrepresented confidential employees as with the general employees.
4. On April 5, 2010, the City Council approved an MOU with the San Fernando Part-time Employees' Bargaining Unit (SFPEBU) that includes certain changes in benefits for FY 2009-2010 through FY 2011-2012.
5. On July 19, 2010, the City Council approved an amendment to the salary and benefits for the Police Chief.

Consideration to Adopt Resolutions Amending the Salary Schedule and Table of Organization for Fiscal Year (FY) 2015-2016Page 2 of 4

6. On October 13, 2011, the City and the San Fernando Management Group (SFMG) agreed to an amendment to the existing MOU to include certain concessions and changes to previously agreed benefits.
7. On April 4, 2012, the City and SFPEA agreed to a two-year extension of the existing MOU from July 1, 2012 through June 30, 2014.
8. On May 7, 2012, the City Council approved an MOU with the San Fernando Police Officers' Association (SFPOA) that includes certain changes in benefits for FY 2011-2012 through FY 2013-2014.
9. On July 2, 2012, the City and the San Fernando Part-time Employees' Bargaining Unit (SFPEBU) agreed to a two-year extension of the existing MOU from July 1, 2012 through June 30, 2014.
10. On September 17, 2012, the City Council approved a two-year extension of the MOUs with the San Fernando Management Group (SFMG) and the San Fernando Police Civilian Association (SFPCA) from July 1, 2012 through June 30, 2014.
11. On June 17, 2013, agreements were reached with all the bargaining units including SFPCA, SFPEA, SFPOA and SFMG to implement furloughs and/or other concessions between July 1, 2013 and June 30, 2014.
12. On March 3, 2014, the City Council approved an Employment Agreement with new City Manager, Brian Saeki, which includes an amendment to the salary and benefits for the City Manager.
13. In June 2014, the City executed Side Letter Agreements with SFPOA and SFMG, respectively, extending the terms and conditions of the MOUs through June 30, 2015.
14. In August 2014, the City executed a Side Letter Agreement with SFPCA, extending the terms and conditions of the MOU through June 30, 2015, and making minor amendments to fix the shift differential pay issues that pertain to Police Desk Officers.
15. In January 2015, the City executed a Side Letter Agreement with SFPEA, extending the terms and certain provisions of the MOU through June 30, 2017.
16. On June 15, 2015, the City Council approved a four-year MOU with SFPOA that includes certain changes in benefits for FY 2015-2016 through FY 2018-2019.
17. On August 3, 2015, the City Council approved a four-year MOU with the SFPOA-PMU that includes certain changes in benefits for FY 2015-2016 through FY 2018-2019.

Consideration to Adopt Resolutions Amending the Salary Schedule and Table of Organization for Fiscal Year (FY) 2015-2016Page 3 of 4

18. On August 3, 2015, the City Council adopted a Resolution establishing the salary and benefits for non-sworn department heads for FY 2015-2016 through FY 2018-2019.
19. On August 17, 2015, the City Council approved a three-year MOU with SFPCA that includes certain changes in benefits for FY 2015-2016 through FY 2017-2018.
20. On September 21, 2015, the City Council approved a three-year MOU with SFMG that includes certain changes in benefits for FY 2015-2016 through FY 2017-2018.
21. On September 21, 2015, the City Council approved a Side Letter Agreement to the MOU extension with SFPEA.
22. On November 16, 2015, the City Council approved an employment agreement with the City Clerk, as well as an amendment to the City's contract with the City Manager.

ANALYSIS:

The attached Salary Schedule and Table of Organization reflect salary and benefit changes addressed in the FY 2015-2016 Budget, as well as provisions of applicable MOUs and employment agreements that have already been approved by the City Council and implemented as scheduled. However, it is necessary to incorporate the relevant salary and benefit changes in the Salary Schedule for payroll purposes, and for easy one-stop reference.

The Salary Schedule also includes the new minimum wage increases for part-time employees, from \$9.00 to \$10.00 per hour, as mandated by the State of California effective January 1, 2016. Seven (7) part-time job classifications are impacted by this, and the new rates are reflected in the Schedule.

The Salary Schedule also includes certain health and welfare benefits for members of the City Council to the extent that is allowed by applicable Government Code.

CONCLUSION:

Approval of the amended Salary Schedule and Table of Organization is necessary to implement applicable changes in the FY 2015-2016 Budget, as well as the provisions of all previously negotiated MOUs, the State of California minimum wage mandate, employment and side letter agreements.

Consideration to Adopt Resolutions Amending the Salary Schedule and Table of Organization for Fiscal Year (FY) 2015-2016Page 4 of 4

BUDGET IMPACT:

The minimum wage increase to seven part-time job classifications constitutes about an 11% increase. Sufficient funds are included in the FY 2015-2016 Budget to cover this, as well as other salary and benefit adjustments to various groups.

ATTACHMENTS:

- A. Resolution No. 7716
- B. Resolution No. 7717

ATTACHMENT "A"

RESOLUTION NO. 7716

A RESOLUTION OF THE COUNCIL OF THE CITY OF SAN FERNANDO ADOPTING A SALARY PLAN FOR CERTAIN ELECTED, NON-ELECTIVE OFFICERS AND EMPLOYEES OF THE CITY OF SAN FERNANDO AND REPEALING RESOLUTION NO. 7680 ADOPTED JUNE 15, 2015 AND ALL RESOLUTIONS AMENDATORY THEREOF AND ALL MOTIONS OR ACTIONS OF THE CITY COUNCIL IN CONFLICT HEREWITH.

THE COUNCIL OF THE CITY OF SAN FERNANDO DOES RESOLVE AS FOLLOWS:

SECTION 1:

The following schedules are hereby adopted as the salary range and step schedules for non-elective officers and employees of the City of San Fernando:

- **SCHEDULE "G": FOR GENERAL - SAN FERNANDO PUBLIC EMPLOYEES' ASSOCIATION (SFPEA)**
- **SCHEDULE "GPD": FOR GENERAL - SAN FERNANDO POLICE CIVILIANS' ASSOCIATION (SFPCA)**
- **SCHEDULE "C": FOR CONFIDENTIAL EMPLOYEES**
- **SCHEDULE "P": FOR SWORN - SAN FERNANDO POLICE OFFICERS' ASSOCIATION (SFPOA)**
- **SCHEDULE "MP": FOR SWORN - SAN FERNANDO POLICE OFFICERS' ASSOCIATION MANAGEMENT UNIT (SFPOA-PMU)**
- **SCHEDULE "M": FOR DEPARTMENT HEADS AND NON-SWORN MANAGEMENT EMPLOYEES**
- **SCHEDULE "H": FOR HOURLY - SAN FERNANDO PART-TIME EMPLOYEES' BARGAINING UNIT (SFPEBU)**
- **SCHEDULE "HFE": FOR HOURLY FULL-TIME EQUIVALENT - SAN FERNANDO PART-TIME EMPLOYEES' BARGAINING UNIT (SFPEBU)**

(Details of the respective schedules are on pages 2 thru 8).

**SCHEDULE G
FOR
GENERAL EMPLOYEES**

SALARY RANGE NUMBER	STEP A	STEP B	STEP C	STEP D	STEP E
60	2885	3033	3193	3359	3533
61	2914	3059	3212	3373	3542
62	2943	3106	3277	3456	3645
63	2987	3137	3295	3457	3630
64	3003	3168	3344	3527	3720
65	3048	3214	3392	3580	3777
66	3090	3256	3436	3627	3826
67	3135	3309	3490	3680	3884
68	3182	3356	3539	3736	3940
69	3225	3402	3590	3786	3994
70	3268	3445	3636	3833	4045
71	3316	3498	3689	3894	4107
72	3357	3541	3736	3940	4158
73	3406	3594	3790	3998	4219
74	3441	3633	3831	4043	4264
75	3494	3687	3894	4103	4329
76	3540	3736	3939	4156	4384
77	3615	3816	4024	4246	4478
78	3635	3833	4045	4266	4502
79	3689	3893	4106	4332	4570
80	3739	3945	4162	4391	4631
81	3818	4026	4248	4480	4727
82	3853	4065	4288	4523	4771
83	3910	4125	4353	4591	4844
84	3970	4186	4416	4661	4916
85	4028	4252	4483	4731	4989
86	4090	4315	4551	4801	5065
87	4157	4385	4627	4881	5150
88	4219	4450	4696	4955	5227
89	4284	4518	4766	5028	5305
90	4347	4586	4838	5104	5384
91	4412	4655	4911	5181	5465
92	4479	4725	4985	5259	5549
93	4546	4796	5060	5339	5631
94	4616	4870	5137	5419	5720
95	4685	4943	5216	5503	5804
96	4754	5017	5294	5584	5890
97	4827	5091	5371	5668	5979
98	4900	5170	5452	5751	6069
99	4972	5245	5533	5840	6160

Schedule G For General Employees (Continued).

SALARY RANGE NUMBER	STEP A	STEP B	STEP C	STEP D	STEP E
100	5047	5326	5617	5925	6252
101	5122	5404	5701	6015	6344
102	5197	5484	5786	6104	6440
103	5277	5567	5872	6196	6535
104	5356	5649	5959	6289	6635
105	5436	5733	6050	6381	6733
106	5518	5820	6142	6477	6834
107	5601	5906	6233	6573	6937
108	5685	5995	6327	6673	7041
109	5771	6086	6422	6773	7147
110	5856	6176	6518	6874	7253
111	5944	6269	6617	6979	7363
112	6034	6364	6715	7083	7474
113	6125	6459	6817	7190	7586
114	6216	6556	6918	7297	7700
115	6310	6654	7022	7406	7816
116	6404	6754	7127	7517	7932
117	6500	6855	7234	7631	8052
118	6598	6958	7343	7745	8173
119	6697	7063	7453	7861	8295

**SCHEDULE GPD
FOR
GENERAL EMPLOYEES
(POLICE DEPARTMENT)**

SALARY RANGE NUMBER	STEP A	STEP B	STEP C	STEP D	STEP E
70	3060	3224	3402	3591	3788
71	3105	3275	3455	3644	3845
72	3151	3322	3504	3699	3901
73	3197	3371	3557	3752	3958
74	3243	3420	3608	3806	4014
75	3290	3468	3659	3860	4073
76	3336	3519	3712	3917	4132
77	3385	3569	3765	3973	4190
78	3433	3620	3820	4030	4252
79	3483	3673	3875	4089	4313
80	3533	3725	3931	4148	4375
81	3584	3779	3987	4207	4437
82	3636	3833	4045	4268	4501
83	3686	3891	4104	4330	4567
84	3702	3906	4120	4348	4585

Schedule GPD For General Employees - Police Department (Continued).

SALARY RANGE NUMBER	STEP A	STEP B	STEP C	STEP D	STEP E
85	3765	3971	4188	4420	4662
86	3796	4007	4227	4460	4704
87	3894	4106	4332	4569	4820
88	3952	4167	4396	4639	4893
89	4011	4230	4464	4707	4966
90	4072	4293	4530	4778	5041
91	4108	4323	4552	4795	5049
92	4194	4423	4668	4922	5193
93	4258	4490	4737	4996	5271
94	4321	4557	4808	5071	5350
95	4387	4626	4881	5147	5430
96	4452	4695	4954	5224	5512
97	4519	4765	5027	5303	5594
98	4586	4837	5103	5382	5678
99	4655	4909	5180	5463	5764
100	4726	4984	5258	5545	5851
101	4798	5060	5337	5630	5938
102	4869	5134	5417	5714	6028
103	4941	5212	5500	5800	6119
104	5017	5290	5582	5887	6211
105	5093	5371	5666	5976	6304
106	5169	5451	5751	6065	6399
107	5247	5533	5838	6157	6495

**SCHEDULE C
FOR
CONFIDENTIAL EMPLOYEES**

SALARY RANGE NUMBER	STEP A	STEP B	STEP C	STEP D	STEP E
68	3891	4086	4288	4502	4728
69	3988	4185	4396	4615	4846
70	4088	4292	4507	4730	4967
71	4188	4397	4617	4848	5090
72	4293	4508	4732	4971	5220
73	4400	4621	4853	5095	5348
74	4511	4736	4973	5222	5482
75	4624	4855	5097	5351	5620
76	4738	4976	5225	5485	5759
77	4857	5100	5356	5624	5904
78	4981	5230	5493	5768	6055
79	5108	5363	5633	5915	6209
80	5238	5500	5777	6065	6367
81	5372	5640	5924	6220	6530
82	5509	5784	6075	6379	6696

Schedule C For Confidential Employees (Continued).

**SCHEDULE C
FOR
CONFIDENTIAL EMPLOYEES**

SALARY RANGE NUMBER	STEP A	STEP B	STEP C	STEP D	STEP E
83	5649	5932	6230	6541	6867
84	5793	6083	6389	6708	7042
85	5941	6238	6552	6879	7222
86	6092	6397	6719	7055	7406
87	6240	6552	6882	7226	7586
88	6392	6712	7049	7402	7770

**SCHEDULE P
FOR
SWORN POLICE EMPLOYEES**

SALARY RANGE NUMBER	STEP A	STEP B	STEP C	STEP D	STEP E
73	5341	5634	5947	6270	6617
74	5394	5689	6005	6333	6683
75	5448	5747	6066	6396	6749
76	5503	5805	6127	6460	6816
77	5558	5863	6188	6524	6884
78	5613	5921	6250	6590	6953
79	5670	5981	6313	6656	7023
80	5726	6040	6375	6721	7094
81	5784	6100	6439	6789	7164
82	5841	6162	6503	6857	7236
83	5900	6224	6567	6928	7311
84	5959	6287	6635	6997	7383
85	6018	6349	6702	7067	7456
86	6079	6413	6769	7138	7531
87	6139	6477	6836	7209	7606
88	6201	6542	6905	7281	7682
89	6263	6607	6974	7354	7759
90	6325	6673	7044	7428	7837
91	6389	6740	7114	7502	7915
92	6453	6807	7185	7577	7994
93	6517	6875	7257	7653	8074
94	6582	6944	7330	7729	8155
95	6640	7005	7390	7797	8228

**SCHEDULE MP
FOR
SWORN POLICE MANAGEMENT**

SALARY RANGE NUMBER	STEP A	STEP B	STEP C	STEP D	STEP E
70	8048	8451	8872	9316	9783
71	8219	8630	9062	9515	9991
72	8394	8814	9255	9718	10204
73	8573	9002	9452	925	10421
74	8756	9194	9654	10136	10643
75	8941	9388	9857	10350	10868

**SCHEDULE M
FOR
DEPARTMENT HEADS & NON-SWORN MANAGEMENT**

SALARY RANGE NUMBER	STEP A	STEP B	STEP C	STEP D	STEP E
55	5373	5642	5926	6223	6535
56	5491	5767	6054	6357	6674
57	5612	5893	6188	6496	6824
58	5736	6021	6322	6639	6971
59	5850	6142	6449	6772	7109
60	5997	6297	6612	6941	7290
61	6147	6454	6775	7115	7471
62	6300	6616	6947	7293	7658
63	6458	6781	7120	7476	7850
64	6619	6949	7297	7662	8045
65	6785	7122	7480	7855	8248
66	6954	7302	7666	8049	8453
67	7128	7483	7859	8252	8664
68	7271	7634	8016	8416	8837
69	7457	7827	8219	8631	9062
70	7539	8021	8421	8843	9286
71	7714	8099	8503	8929	9377
72	7902	8297	8712	9149	9606
73	8271	8685	9119	9575	10053
74	8560	8988	9438	9910	10406
75	8732	9168	9627	10108	10613
76	8950	9397	9867	10361	10879
77	9174	9634	10118	10626	11159
78	9403	9875	10371	10892	11438
79	9639	10120	10625	11158	11715
80	9830	10322	10840	11380	11949
81	9930	10426	10948	11495	12068

**SCHEDULE H
FOR
PART-TIME HOURLY EMPLOYEES**

SALARY RANGE NUMBER	STEP A	STEP B	STEP C	STEP D	STEP E
44	10.00	10.44	10.90	11.39	11.90
45	10.15	10.59	11.05	11.54	12.05
46	10.27	10.78	11.32	11.89	12.48
47	10.48	10.96	11.46	11.98	12.53
48	10.58	11.06	11.56	12.09	12.64
49	10.68	11.16	11.66	12.19	12.74
50	10.78	11.26	11.76	12.29	12.84
51	10.88	11.36	11.56	12.39	12.94
52	10.97	11.47	11.99	12.54	13.12
53	11.07	11.57	12.09	12.64	13.27
54	11.14	11.69	12.28	12.89	13.54
55	11.25	11.81	12.40	13.02	13.67
56	11.32	11.95	12.63	13.13	13.78
57	11.45	12.02	12.63	13.26	13.92
58	11.57	12.15	12.75	13.39	14.06
59	11.68	12.27	12.88	13.52	14.20
60	11.80	12.39	13.01	13.66	14.34
61	11.92	12.51	13.14	13.80	14.49
62	12.04	12.64	13.27	13.93	14.63
63	12.16	12.76	13.40	14.07	14.78
64	12.28	12.89	13.54	14.21	14.92
65	12.40	13.02	13.67	14.36	15.07
66	12.53	13.15	13.81	14.50	15.22
67	12.65	13.28	13.95	14.64	15.38
68	12.78	13.42	14.09	14.79	15.53
69	12.90	13.54	14.22	14.93	15.68
70	13.03	13.68	14.36	15.08	15.83
71	13.16	13.82	14.51	15.23	15.99
72	13.30	13.94	14.62	15.33	16.08
73	13.42	14.09	14.80	15.54	16.31
74	13.68	14.37	15.09	15.84	16.63
75	13.78	14.47	15.34	15.94	16.73
76	13.88	14.57	15.44	16.04	16.83
77	13.99	14.67	15.54	16.14	16.93
78	14.09	14.77	15.64	16.24	17.03
79	14.19	14.92	15.79	16.39	17.18
80	14.29	15.07	15.84	16.44	17.23
81	14.42	15.21	16.06	16.94	17.87
82	15.27	16.10	17.00	17.94	18.92
83	15.71	16.57	17.50	18.46	19.47

Schedule H For Part-time Hourly Employees (Continued).

SALARY RANGE NUMBER	STEP A	STEP B	STEP C	STEP D	STEP E
84	16.17	17.05	18.00	18.99	20.04
85	16.63	17.54	18.50	19.52	20.60
86	17.08	18.02	19.01	20.06	21.16
87	17.53	18.49	19.51	20.58	21.72
88	17.98	18.97	20.01	21.11	22.27
89	18.43	19.44	20.51	21.64	22.83
90	18.88	19.92	21.01	22.17	23.39
91	19.33	20.39	21.51	22.70	23.95
92	19.81	20.89	22.04	23.25	24.53
93	20.22	21.34	22.50	23.74	25.04

**SCHEDULE HFE
FOR
PART TIME HOURLY EMPLOYEES
(Full-Time Equivalent)**

SALARY RANGE NUMBER	STEP A	STEP B	STEP C	STEP D	STEP E
95	18.18	19.17	20.22	21.34	22.51
96	18.35	19.36	20.42	21.55	22.73
97	18.53	19.55	20.63	21.76	22.96
98	18.72	19.75	20.83	21.98	23.19
99	18.91	19.95	21.04	22.20	23.42
100	19.09	20.14	21.25	22.42	23.65
101	19.29	20.35	21.47	22.65	23.89
102	19.48	20.55	21.68	22.87	24.13
103	19.81	20.89	22.04	23.25	24.53
104	20.00	21.10	22.26	23.48	24.77
105	20.22	21.34	22.50	23.74	25.04
106	20.41	21.53	22.72	23.97	25.29
107	20.46	21.68	22.98	24.19	25.48
108	20.77	21.92	23.12	24.39	25.74
109	20.98	22.14	23.35	24.64	25.99
110	21.19	22.36	23.59	24.88	26.25
111	21.40	22.58	23.82	25.13	26.52
112	21.62	22.81	24.06	25.38	26.78
113	21.83	23.04	24.30	25.64	27.05
114	22.05	23.27	24.55	25.90	27.32
115	22.33	23.56	24.87	26.23	27.66

SECTION 2: ELECTED, NON-ELECTIVE OFFICERS AND EMPLOYEES

The following non-elective officers and employees of the City of San Fernando shall be paid for their services to the City the compensation as hereinafter set forth.

- (A) SALARY RANGE NUMBER AND SCHEDULES ASSIGNED** – Non-elected officers and employees set forth in this subsection (a) shall be paid the salary and wages for the classification assigned at the range and step of the applicable salary schedule.

CLASSIFICATION	SALARY RANGE NUMBER/ SCHEDULE	STEP A	STEP B	STEP C	STEP D	STEP E
Associate Planner	104G	5356	5649	5959	6289	6635
Building Maintenance Worker/ Electrical Helper	77G	3615	3816	4024	4246	4478
Building & Safety Supervisor	111G	5944	6269	6617	6979	7363
City Clerk	FLAT RATE	8421.08				
City Manager	FLAT RATE	15416.67				
Civil Engineering Assistant II	112G	6034	6364	6715	7083	7474
Community Preservation Officer	83G	3871	4084	4310	4546	4795
Community Development Director	76M	8950	9397	9867	10361	10879
Community Development Secretary	84G	3970	4186	4416	4661	4916
Community Services Supervisor	96G	4754	5017	5294	5584	5890
Cultural Arts Supervisor	96G	4754	5017	5294	5584	5890
Deputy City Manager/ Public Works Director	79M	9639	10120	10625	11158	11715
Director of Recreation and Community Services	75M	8732	9168	9627	10108	10613
Electrical Supervisor	103G	5277	5567	5872	6196	6535
Equipment and Materials Supervisor	103G	5277	5567	5872	6196	6535
Executive Assistant to the City Manager	77C	4857	5100	5356	5624	5904
Finance Director	75M	8732	9168	9627	10108	10613

CLASSIFICATION	SALARY RANGE NUMBER/SCHEDULE	STEP A	STEP B	STEP C	STEP D	STEP E
Finance Office Specialist	75G	3494	3687	3894	4103	4329
Junior Accountant	97G	4827	5091	5371	5668	5979
Management Analyst	55M	5373	5642	5926	6223	6535
Mechanical Helper	74G	3441	3633	3831	4043	4264
Meter Technician	80G	3739	3945	4162	4391	4631
Office Clerk	64G	3003	3168	3344	3527	3720
Office Specialist	78G	3635	3833	4045	4266	4502
Personnel Manager	68M	7271	7634	8016	8416	8837
Personnel Technician	71C	4188	4397	4617	4848	5090
Police Cadet	73P	5341	5634	5947	6270	6617
Police Chief	FLAT RATE	12,000				
Police Desk Officer	91GPD	4108	4323	4552	4795	5049
Police Lieutenant	75MP	8941	9388	9857	10350	10868
Police Office Specialist	78GPD	3433	3620	3820	4030	4252
Police Officer	73P	5341	5634	5947	6270	6617
Police Records Specialist	72GPD	3151	3322	3504	3699	3901
Police Records Supervisor/ Systems Administrator	105GPD	5093	5371	5666	5976	6304
Police Sergeant	95P	6640	7005	7390	7797	8228
Program Specialist	76G	3540	3736	3939	4156	4384
Property Control Officer	81GPD	3584	3779	3987	4207	4437
Public Works Administrative Coordinator	87G	4157	4385	4627	4881	5150
Public Works Field Supervisor I	90G	4347	4586	4838	5104	5384
Public Works Field Supervisor II	97G	4824	5091	5371	5668	5979
Public Works Maintenance Worker	74G	3441	3633	3831	4043	4264
Public Works Office Specialist	84G	3970	4186	4416	4661	4916

CLASSIFICATION	SALARY RANGE NUMBER/SCHEDULE	STEP A	STEP B	STEP C	STEP D	STEP E
Public Works Superintendent	113G	6125	6459	6817	7190	7586
Recreation Supervisor	96G	4754	5017	5294	5584	5890
Secretary to the Chief	87GPD	3894	4106	4332	4569	4820
Senior Account Clerk	75G	3494	3687	3894	4103	4329
Senior Account Clerk II	68C	3891	4086	4288	4502	4728
Senior Maintenance Worker	81G	3818	4026	4248	4480	4727
Treasurer Assistant	85G	4028	4252	4483	4731	4989
Water Pump Operator/ Backflow Technician	84G	3970	4186	4416	4661	4916

(B) SEASONAL AND HOURLY POSITIONS – Seasonal employees and employees hired on an hourly basis shall be paid hourly rates for assigned classifications as follows:

CLASSIFICATION	SALARY RANGE NUMBER/SCHEDULE	STEP A	STEP B	STEP C	STEP D	STEP E
Cashier	53H	11.07	11.57	12.09	12.64	13.27
City Maintenance Helper	81H	14.42	15.21	16.06	16.94	17.87
Community Service Officer	92H	19.81	20.89	22.04	23.25	24.53
Community Preservation Officer	115HFE	22.33	23.56	24.87	26.23	27.66
Crossing Guard	44H	10.00	10.44	10.90	11.39	11.90
Day Camp/After School Counselor	44H	10.00	10.44	10.90	11.39	11.90
Junior Cadet	48H	10.58	11.06	11.56	12.09	12.64
Deputy City Clerk	93H	20.22	21.34	22.50	23.74	25.04
Office Clerk/Cashier	53H	11.07	11.57	12.09	12.64	13.27
Personnel Office Clerk	53H	11.07	11.57	12.09	12.64	13.27
Police Records Specialist	95HFE	18.18	19.17	20.22	21.34	22.51
Pool Attendant/ Cashier	44H	10.00	10.44	10.90	11.39	11.90
Program Specialist	106HFE	20.41	21.53	22.72	23.97	25.29

CLASSIFICATION	SALARY RANGE NUMBER/SCHEDULE	STEP A	STEP B	STEP C	STEP D	STEP E
Public Works Maintenance Helper	81H	14.42	15.21	16.06	16.94	17.87
Recreation Leader I	44H	10.00	10.44	10.90	11.39	11.90
Recreation Leader II	47H	10.48	10.96	11.46	11.98	12.53
Recreation Leader III	71H	13.16	13.82	14.51	15.23	15.99
Senior Day Camp/Senior After School Counselor	52H	10.97	11.47	11.99	12.54	13.12

(C) COMPENSATION FOR COMMISSIONS, BOARDS, AND COMMITTEE MEMBERS

The members of the following commissions, boards, and committees, who are not employees of the City, shall be paid the amount hereinafter specified for each meeting.

<u>COMMISSION OR COMMITTEE</u>	<u>COMPENSATION PER MEETING ATTENDED (NOT TO EXCEED ONE MEETING PER MONTH)</u>
Cultural Arts Commission	\$50.00
Disaster Council	\$50.00
Education Commission	\$50.00
Planning and Preservation Commission	\$50.00
Parks, Wellness, and Recreation Commission	\$50.00
Transportation and Safety Commission	\$50.00
Tree Commission	\$50.00

(D) COMPENSATION FOR COUNCIL MEMBERS

The members of the City Council shall be paid compensation in the amount of \$580.00 per month.

For other benefits applicable to Council members, please refer to Section 3(I) below.

(E) COMPENSATION FOR CITY TREASURER

- (1) The City Treasurer shall be paid compensation in the amount of \$579.06 per month.
- (2) City Treasurer, while acting as Treasurer for Parking Meter Administration (part-time), is paid \$98 per month.

SECTION 3: ADDITIONAL COMPENSATION AND BENEFITS

The following elective and non-elective officers, as well as employees shall be paid compensation in addition to the basic salary set forth in Section 2 as follows:

(A) GENERAL AND CONFIDENTIAL EMPLOYEES

Salary and benefits listed here apply to full-time employees assigned to **Schedule G** for full-time General Employees (SFPEA) and **Schedule GPD** for full-time General, Non-Sworn Police Department Employees (SFPCA), and reflect stipulations in the last MOU, which are contingent upon negotiation of a new MOU. They also apply to full-time regular employees assigned to **Schedule C** for full-time Confidential Employees.

The following salaries and benefits shall apply for **Schedules G, C and GPD**, respectively:

(1) Salary

a) The salary ranges shown under **Schedules G and C** reflects the following, per the last approved MOU/Side Letter:

- Effective on the first day of the pay period including August 1, 2015, the base salary for each of the classifications was increased by one percent (1%).

b) The salary ranges shown under **Schedule GPD** reflects the following, per the last approved MOU:

- 0% COLA for Fiscal Year 2015-2016

In computing benefits that are a percentage of base salary (e.g., Longevity, Special Assignment Pay, etc.), each benefit is calculated independently over the base salary of each respective employee.

(2) Longevity Pay

a) The City shall pay longevity to unit employees that completed 10 years of continuous service from date of hire, an additional 3% above the base salary step for each employee.

b) The City shall pay longevity to unit employees that completed 20 years of continuous service from date of hire, an additional 1% above the base salary and previous first longevity step.

c) The City shall continue to pay longevity to unit employees that completed 30 years of continuous service from date of hire, an additional 1% above the base salary and previous second longevity step.

An employee on leave of absence without pay or any form of leave without pay, with the exception of the Family & Medical Leave (FMLA), shall not have such leave time credited as service time for purposes of calculating the years of service.

(3) Overtime

For non-exempt employees who work under the regular 8A.M. – 5P.M., Monday – Friday schedule, overtime must be paid or compensatory time off granted at the Employee's request as defined in Section 5 below (under CTO) for all hours worked over forty (40) hours in a seven day work period. Non-exempt employees who are under the 9/80 or other flex work schedule shall have designated fixed workweek, and any hours worked over the specified maximum hours within the designated workweek must be paid as overtime or granted compensatory time off at the Employee's request as defined in Section 5 below (under CTO).

The City shall comply with the provisions of the Fair Labor Standard Act (FLSA), and shall define the parameters of a standard workweek.

Overtime shall be paid at the rate of one and one-half (1½) times the regular rate of pay for the excess time (overtime hours) worked during the workweek. The payment of overtime to non-exempt, non-sworn employees will be based upon actual hours worked. Overtime will be equitably distributed amongst qualified employees within their departments and classifications.

Specifically, for non-sworn, SFPCA employees, overtime worked cannot interfere with an employee's assigned work schedule, which may allow 7½ hours between assigned work shifts (e.g., an employee cannot work a twelve-hour shift followed by an overtime shift of more than 4 hours; and then work his/her assigned shift consecutively. This would leave less than 7½ hours of rest time between assigned work shifts).

Specific procedures for assignment of overtime can be found in the respective bargaining unit MOUs.

(4) **Shift Differential Pay**

For general, non-sworn employees, effective the first day of the pay period following Council approval on August 18, 2014 of the SFPCA MOU extension, the City shall discontinue the payment of flex/built-in overtime and the payment for various shifts (differential pays). The flex/built-in overtime and the shift differential pays shall be merged into a flat hourly base rate increase for each Police Desk Officer. The pay for Police Desk Officers has been adjusted by the addition of \$0.90 to the hourly base rate of the salary steps.

(5) **Compensatory Time Off (CTO)**

The maximum number of CTO hours any non-exempt, non-sworn employee may accrue is 100 hours. Comp time hours in excess of 100 hours must be paid at the rate of one and one-half (1-1/2) times the regular rate of pay.

The scheduling and use of CTO shall be subject to the approval of the employee's department head. An employee who has requested the use of CTO is permitted to use such time "within a reasonable period" after making the request, unless it is determined that the employee's request would "unduly disrupt" the department operations or impose an unreasonable burden on the department's ability to provide services of acceptable quality and quantity for the public during the time required without the use of the employee's services.

(6) **Holiday Leave**

Employees who work a 5/8 and 9/80 who are required to work on a holiday shall receive holiday compensation at the rate of time and one-half (1-1/2) times their normal rate of pay in addition to pay for all hours worked.

Each unit employee shall be entitled to the following holidays with pay:

New Year's Day
 Martin Luther King, Jr. Day
 Presidents' Day

Cesar Chavez Birthday (When Cesar Chavez birthday falls on any day except Monday, the holiday will be observed on the Friday following the actual holiday).

Memorial Day

Independence Day

Labor Day

Columbus Day (Replaced effective January 1, 2010 with Float day)

Float day – “Front loaded” each July 1, if not used by June 30 of the subsequent year, Float day is lost.

Veteran’s Day

Thanksgiving Day

Day after Thanksgiving

Christmas Day

Employees who work a modified 3/12 work week shall be granted the same holidays as above and shall accrue 96 hours of holiday leave per year, and shall be credited with 48 hours of holiday leave each January 1st and an additional 48 hours of Holiday leave each July 1st. Employees on the 3/12 work week shall schedule holiday leave in accordance with Police Departmental procedures.

Employees on the 3/12 work week will only be permitted to carry over 96 hours of accrued but unused holiday leave from one calendar year to the next. Employees on the 3/12 work week who, as of January 1st, have not lowered their accrued Holiday leave to 96 hours or less, shall not accrue additional hours until such time as the employee brings his/her accrual to (or under) the 96 hour cap. At that time, the employee will receive his/her full 48 hour allotment for that half year. Upon employee’s separation from the City, any unused holiday leave shall be compensated at his/her regular rate of pay.

(7) **Sick Leave**

The City shall allow any employee upon retiring by reason of reaching retirement age under CalPERS to be paid at the then prevailing rate of pay, one half (1/2) of accumulated and unused sick leave time (total of employee’s “sick leave bank” plus the accumulated sick leave for the current year) not to exceed a maximum of the employee’s one (1) month pay.

Sick leave is accrued on a payroll-to-payroll basis at the rate of 8 hours per month, with maximum accrual of 800 hours. All time accrued in excess of 800 hours shall be paid at the end of the calendar year, at the rate of 35% of the amount in excess of 800 hours at their regular rate of pay.

Sick leave shall be considered as “actual time worked” for purposes of calculating overtime premium pay. The City may request a doctor’s note after the third (3rd) day of illness.

(8) **Bereavement Leave**

The City shall authorize unit members to utilize up to three (3) days paid bereavement per incident following the death of a member of their immediate family. Any additional bereavement days off shall be subject to the approval of the department head on a case-by-case basis. The unit member may utilize accrued sick time during bereavement period for additional time off if needed.

For the purposes of implementing this benefit, "Immediate Family" shall mean grandparent, parent, child, spouse or registered domestic partner as permitted by California law, or any person living in the household. Proof of residence may be required. "Parent" shall mean biological, foster or adoptive parent, stepparent, legal guardian or person who has parental rights to employee. "Child" shall mean a biological, adopted or foster child, stepchild, legal ward or a child of a person who has parent's rights.

The City shall authorize unit members to utilize one (1) paid day following the death of an extended family member. For the purpose of implementing this benefit, "Extended Family" shall mean: Aunts, Uncles, and Cousins, god-parents or god-parent equivalent.

Verification may be requested.

(9) **Callback**

Any employee called back to work other than as a continuation (immediately preceding or following) of his/her regular established work schedule shall be compensated at the rate of pay equal to one and one-half (1½) times his/her regular hourly pay. The minimum period to be compensated for any such "**callback**" time shall be two (2) hours.

(10) **Stand-By Pay**

Water Division employees who are assigned to mandatory stand-by on the weekends and holidays shall be entitled to stand-by pay at the rate of \$1.50 per hour during the period when they are required to stand-by.

In addition, Street, Tree and Facilities Division employees who are assigned to mandatory stand-by on the weekends and holidays shall be entitled to stand-by pay at the rate of \$1.00 per hour during the period when they are required to stand-by. ***At no point shall more than three employees be on stand-by from all the divisions combined.***

(11) **Bilingual Pay**

A bonus of \$100.00 per month shall be paid to those unit employees that qualify in accordance with the following conditions:

- a) The employee has demonstrated to the satisfaction of the City his/her fluency in the Spanish language based on an oral testing procedure selected by the City; and
- b) The employee is required in the normal course of his/her duties to communicate in Spanish with members of the public, as determined by the department head and approved in writing by the City Manager.

(12) **Special Projects Bonus Pay**

Workers in Public Works when assigned to the Special Projects Squad shall receive \$5.00 per hour for each hour worked on designated special projects, Special Projects pay will not be paid in addition to Inspector pay. No more than 3 persons will be authorized to receive Special Projects pay for any project; a fourth employee may be assigned to the Special Projects crew at the discretion of the Deputy City Manager/Public Works Director only.

(13) **Inspector Duty Pay**

The City agrees to continue the specialized inspector pay provisions consistent with agreed upon procedures including but not limited to requiring approval by the department head and providing for no more than one inspector per project except by official exemption.

Any eligible Public Works field/building maintenance, utility, and/or supervisory employee that is required and scheduled to perform Inspection duties will be compensated at the rate of an additional \$6.00 per hour over his or her base salary, for those hours spent on inspection. To be eligible for Inspection Duty Pay, the staff member must be certified, and be on a Certification List developed by the Public Works Director or his designee.

The job classifications eligible to participate in this program include: Public Works Maintenance Worker; Senior Maintenance Worker; Public Works Field Supervisor I; and Public Works Field Supervisor II.

(14) **Weekend Bonus Pay**

The City shall codify and continue the existing provisions applicable to workers assigned to rotating weekend work assignments within Public Works when a Public Works field staff worker is scheduled to work weekends.

Any eligible Public Works field/building maintenance, utility, and/or supervisory employee that is *required and scheduled* to perform Weekend Shift duties will be compensated at the rate of an additional \$2.50 per hour over his or her base salary, for those hours spent on weekend assignment.

To be eligible for Weekend Shift Pay, the staff member must be regularly assigned and scheduled to work a weekend. Compensation for weekend shift shall be the regular employee's salary plus the weekend duty pay for hours worked on weekends. Weekend Shift Pay shall not be included in the determination of Overtime premium rate or comp time. It shall not be combined with other established premium compensation such as stand-by pay, or any other shift pay.

The job classifications eligible to participate in this program include: Public Works Maintenance Worker; Senior Maintenance Worker; Public Works Field Supervisor I; Public Works Field Supervisor II; Water Pump Operator/Backflow Technician; Meter Technician; Electrical Technician; Mechanical Helper and Master Mechanic.

(15) **Uniform Allowance**

The City shall provide uniforms and/or equipment, as well as provide allowances as follows:

- a) Public Works field employees shall be provided with the following annually unless otherwise specified:
 - A pair of work boots made by Timberland, Red Wing, Wolverine, Stanley Cat, Bates, Chippewa, Carolyn, Sears or Dye Hard consistent with Cal OSHA's ANSI Z41.1 standard. Local Vender, specifications and brands to be provided by the City based on the job performed;
 - A jacket with bi-yearly replacement, subject to department head approval.
 - A uniform voucher not to exceed \$200.00 annually.
 - A pair of work shoes for Meter Technicians.

All purchases shall be made in accordance with the City's purchasing policy. It is further agreed that these will be deducted from the final salary payment of any employee failing to satisfactorily complete his probationary period.

- b) For non-sworn, full-time employees in the Police Department, the City shall provide two (2) complete sets of uniforms, plus raise the annual uniform allowance from \$250 to \$300. In addition, unit employees who are required to wear certain shoes/boots for their position will receive \$100 yearly (fiscal year) for purchase of work shoes/boots. All purchases shall be made in accordance with the City's purchasing policy.

The uniforms shall consist of:

Clerical – Blouse, skirt, pants, blazer, and vest

Police Desk Officer – Pants, skirt, shirt, and belt

Community Service Officer – Pants, shirt, jacket, and belt and name tag.

- c) Community Development Department field workers shall be provided with an initial issue of one appropriate jacket with bi-yearly replacements subject to department head approval and a pair of work shoes annually.
- d) Community Preservation Officers will be provided with a uniform as required by the department. All purchases shall be made in accordance with the City's purchasing policy.

Where uniform allowances are to be paid under Sections 15A, 15B, 15C, 15D above, they shall be paid semi-annually in December and in June. Worn uniforms shall be replaced by the City subject to the department head's approval. All worn uniforms must be turned in upon being replaced.

(16) **Court Appearance Pay**

Any bargaining unit employee required to appear in court on behalf of the City during off-duty hours, shall be paid at one and one-half (1 ½) times his/her regular rate of pay for the duration of the court appearance, with a minimum of two (2) hours.

(17) **Acting Pay/Working Out of Class**

Any assignment to perform duties of a higher level position or act in a higher capacity outside one's job classification will be paid at the rate of 5% higher than one's current salary. The City shall ensure that anyone working in a higher capacity is adequately trained to fulfill the requirements of that higher class. Only trained Police Department personnel should be allowed to perform strip searches or Jailer duties. Assignments to perform higher-level duties must be formal and in writing, and approved by the department head.

(18) **Time Off for Promotional Tests or Interviews**

Employees shall be required to utilize their own time (e.g., unused Vacation or Compensatory time) for purposes of taking tests or participating in interviews within or outside the City. Procedure for such time off shall be consistent with existing City policy.

(19) **Workers' Compensation**

In those instances when an employee experiences an injury which is recognized as job-related by the City or the Worker's Compensation Appeals Board, and the employee is

absent from work because of the injury, the employee shall receive full pay for the first ten (10) working days of disability without charge against accumulated sick leave. Thereafter, the injured employee shall have the following options:

- a) Remain on full pay with time charged against accumulated earned leave (sick leave/vacation). The injured employee shall remit his/her worker's compensation check to the City, and the City shall then credit back appropriated leave time in relation to the amount of the check. Upon using all accumulated leave time, the injured employee shall retain the disability time off. Employees may choose to only use sick leave and not vacation under this provision; or
- b) Accept the worker's compensation check as compensation during the period of disability with no time charged against accumulated earned leave time.

The City agrees to continue full payment of all insurance premiums for the duration of any job-related injury or illness at the same level as the employee had prior to his/her injury regardless of whether or not the employee is on payroll.

In accordance with CalPERS stipulations, as soon as it is believed that a unit employee is unable to perform his/her job because of an illness or injury which is expected to be permanent or last longer than six months, the employee may request that the City accommodate/transfer him/her to a less demanding vacant position. Should there not be a vacant position available, the City shall have the option to submit an application for disability retirement on the employee's behalf, provided that the employee has attained five or more years of service. However, nothing in this provision, takes away the employee's option to waive the right to retire for disability and/or elect to resign and withdraw his/her share of retirement contributions. If the employee has attained normal service retirement eligibility, he/she shall have the right to elect service retirement as provided in Government Code Section 20731. The injury or disease causing the incapacity or disability need not be job-related.

(20) **Tuition Reimbursement**

The City shall reimburse tuition for approved courses to unit members to a maximum of \$3,000 per fiscal year. Department heads and employees should make every effort to submit accurate requests for tuition reimbursement during the annual budget process.

Tuition reimbursement shall be contingent upon employee satisfactorily completing course(s) with a minimum of a "C" Grade, and commit to continued service to the City of San Fernando for the equivalent of the school units, not to exceed two years.

Employees enrolled in an approved tuition reimbursement program may charge mileage beyond ten (10) miles against tuition reimbursement at the current IRS rate.

(21) **Other Benefits**

For other benefits such as medical, dental, vision insurance, and retirement, that apply to Schedules G, C, and GPD, please refer to their specific MOUs (Contract Nos. 1624 & 1794).

(B) PART-TIME EMPLOYEES

Salary and benefits listed here apply to part-time employees assigned to **Schedule H** for “Hourly” employees, and **Schedule HFE** for “Hourly Full-Time Equivalent” employees, and reflect stipulations in the last MOU. These stipulations may change contingent upon negotiation of a new MOU.

(1) Salary

The hourly rates shown under **Schedules H** and **HFE** reflect existing salaries, and the following shall apply:

Fiscal Year 2015/2016 – 0% cost of Living Adjustment (COLA). However, the wages for certain part-time job classifications that are currently placed below \$10.00 per hour have been increased by about 11% in compliance with the State of California’s mandatory minimum wage increase in January 2016 from \$9.00 to \$10.00 per hour.

(2) Sick, Vacation, Holiday and Bereavement Leave

a) Employees may earn a bank of 24 hours per calendar year under the following criteria:

- i. The employee must be employed as of July 1, 2009 and have two years of continuous employment with no breaks in service except layoff.
- ii. The employee must work at least 1,000 hours during the last year.
- iii. The employee will be credited with a 24 hour paid time off bank beginning the first of the calendar year following the year the employee has met the requirements one and two listed above.
- iv. There is no accumulation of hours that may be carried from one calendar year to another.
- v. This paid time off can be used for sick, vacation, holiday or bereavement.

b) Employees may earn a bank of 48 hours per calendar year under the following criteria:

- i. The employee must be employed as of July 1, 2009 and have six years of continuous employment with no breaks in service except layoff.
- ii. The employee must work at least 1,000 hours during the last year.
- iii. The employee will be credited with a 48 hour paid time off bank beginning the first of the calendar year following the year the employee has met the requirements one and two listed above.
- iv. There is no accumulation of hours that may be carried from one calendar year to another.
- v. This paid time off can be used for sick, vacation, holiday or bereavement

- c) Employees may earn a bank of 60 hours per calendar year under the following criteria:
 - i. The employee must be employed as of July 1, 2009 and have nine years of continuous employment with no breaks in service except layoff.
 - ii. The employee must work at least 1,000 hours during the last year.
 - iii. The employee will be credited with a 60 hour paid time off bank beginning the first of the calendar year following the year the employee has met the requirements one and two listed above.
 - iv. There is no accumulation of hours that may be carried from one calendar year to another.
 - v. This paid time off can be used for sick, vacation, holiday or bereavement
 - d) Employees may earn a bank of 72 hours per calendar year under the following criteria:
 - i. The employee must be employed as of July 1, 2009 and have twelve years of continuous employment with no breaks in service except layoff.
 - ii. The employee must work at least 1,000 hours during the last year.
 - iii. The employee will be credited with a 72 hour paid time off bank beginning the first of the calendar year following the year the employee has met the requirements one and two listed above.
 - iv. There is no accumulation of hours that may be carried from one calendar year to another.
 - v. This paid time off can be used for sick, vacation, holiday or bereavement
- (3) **Bilingual Pay**
- a) A bonus of \$50.00 per month shall be paid at the end of each month worked to those unit employees that qualify in accordance with the following conditions:
 - i. The employee must work eighty (80) hours or less per month.
 - ii. The employee has demonstrated to the satisfaction of the City his/her fluency in the Spanish language based on an oral testing procedure selected by the City; and
 - iii. The employee is required in the normal course of his/her duties to communicate in Spanish with members of the public, as determined by the department head and approved in writing by the City Manager.
 - b) A bonus of \$100.00 per month shall be paid at the end of each month worked to those unit employees that qualify in accordance with the following conditions:
 - i. The employee must work eighty (80 +) hours per month.
 - ii. The employee has demonstrated to the satisfaction of the City his/her fluency in the Spanish language based on an oral testing procedure selected by the City; and the

employee is required in the normal course of his/her duties to communicate in Spanish with members of the public, as determined by the department head and approved in writing by the City Manager.

(4) **Uniform Allowance/Equipment**

The City shall provide uniforms as follows:

- a) For non-sworn, part time employees in the City who are required to wear uniforms, the City shall provide one (1) complete set of uniforms per the assignment and replace as needed. The uniforms shall consist of those that the department deems necessary. All purchases shall be made in accordance with the City's purchasing policy.
- b) Rain Gear - The City shall provide rain gear to employees assigned to work in the rain.

(5) **Working Out of Class**

Any assignment to perform duties of a higher level position or act in a higher capacity outside one's job classification will be paid at the rate of at least 5% higher than one's current salary. The City shall ensure that anyone working in a higher capacity is adequately trained to fulfill the requirements of that higher class. Assignments to perform higher-level duties must be formal and in writing, and approved by the Department Head.

(6) **Time Off for Promotional Tests or Interviews**

Employees shall be required to utilize their own time (e.g., unused Vacation or Compensatory time) for purposes of taking tests or participating in interviews within or outside the City. Procedure for such time off shall be consistent with existing City policy.

(C) **POLICE OFFICERS' ASSOCIATION**

Salary and benefits listed here apply to regular full time employees assigned to **Schedule P**, for Sworn Police Officers and Sergeants, and reflect stipulations in the last MOU.

(1) **Salary**

The salary ranges shown under **Schedule P** reflects the following, per the last approved MOU:

- Effective on the first day of the pay period beginning after July 1, 2015, the base salary for each represented unit classification was increased by one percent (1%).

In computing benefits that are a percentage of base salary (e.g., Longevity) each benefit is calculated independently over the base salary of each respective employee.

(2) **Longevity Pay**

For unit employees hired prior to January 1, 2012:

The City shall pay longevity to all eligible unit members as follows:

- a) Upon completion of the fifth year of continuous service as a sworn employee with the City, an additional five percent (5%) over and above the base salary step for each employee in this category.
- b) Upon completion of the tenth year of continuous service as a sworn employee with the City, a total of seven and one-half percent (7½%) over and above the base salary step for each employee in this category.
- c) Upon completion of the fifteenth year of continuous service as a sworn employee with the City, a total of ten percent (10%) over and above the base salary step for each employee in this category.

For unit employees hired on or after January 1, 2012:

The City shall pay longevity to all eligible unit members as follows:

- a) Upon completion of the fifth year of continuous service as a sworn employee with the City, an additional three percent (3%) over and above the base salary step for each employee in this category.
- b) Upon completion of the tenth year of continuous service as a sworn employee with the City, a total of four percent (4%) over and above the base salary step for each employee in this category.
- c) Upon completion of the fifteenth year of continuous service as a sworn employee with the City, a total of five percent (5%) over and above the base salary step for each employee in this category.

(3) **Bilingual Pay**

The City shall pay a bilingual bonus of a flat \$100 per month to unit employees required in the normal course of their duties to communicate in Spanish with members of the public. Said payment is subject to the following conditions:

- a) Employee has satisfactorily demonstrated to the City his/her fluency in the Spanish language, based on written and/or oral testing procedures as selected by the City; and
- b) Employee is required in the normal course of his/her duties to communicate in Spanish with members of the public, as determined by the department head and approved in writing by the City Manager.

(4) **Field Training Officer**

The City shall pay any sworn employee whom the department designates as a Field Training Officer (FTO) \$400 per month above his or her base salary.

(5) **Motor Officer**

The City shall pay any sworn employee whom the department designates as a Motor Officer \$400 per month above his or her base salary.

(6) **Canine Officer**

Employees who are assigned to canine officer detail are entitled to compensation for the off-duty hours spent caring for, cleaning, grooming, feeding and training their canine and maintaining (including cleaning) their canine vehicle/unit. The City and the Association acknowledge that the Fair Labor Standards Act, which governs the entitlement to compensation for canine duties, entitles the parties to agree to the approximate number of hours per month spent for the performance of canine duties. The Fair Labor Standards Act also allows the City and the Association to agree on appropriate compensation for the performance of canine duties. It is the intent of the City and the Association through the provisions of this article to fully comply with the requirements of the Fair Labor Standards Act. In addition, the City and the Association believe that the following canine pay provision does comply with the requirements of the Fair Labor Standards Act

The City agrees to pay any sworn employee assigned to canine duties \$400 per month above his or her base salary, plus two (2) hours of premium overtime compensation each week. This amount recognizes that the time spent off duty to care for, clean, feed, groom and train his or her assigned dog and the maintenance (including cleaning) of his or her assigned vehicle/unit shall be considered hours worked. The City and the Association have analyzed this issue and it has been determined that unit members spend, on average, 20 hours per month performing such work off-duty and that the compensation set forth above is adequate.

(7) **Detectives**

The City shall pay any sworn employee whom the department designates as a Detective \$400 per month above his or her base salary.

(8) **POST Certificate Compensation**

Cert/Degree/Units	Before 1/1/12	Effective 1/1/12
Intermediate POST or AA/AS degree	\$229 ofcr/\$285 sgt.	\$200 ofcr/sgt.
Advanced POST or BA/BS degree	Add'l \$164 ofcr/ \$204 sgt.	Add'l \$200 ofcr/sgt.
Supervisory POST or Master's degree	Add'l \$164 ofcr/ \$204 sgt.	Add'l \$300 ofcr/sgt.

a) The following shall apply:

- i. Any employee that was receiving Certificate/Education pay for possession of any degree or certificate shall continue to fall under the provisions of the current program, provided, however, compensation for possession of an Associate degree will be eliminated, except as to employees hired before 1/1/12, who were “grandfathered”.
- ii. Effective January 1, 2012, any employee not receiving any form of Certificate Pay (inclusive of certificates, units or degrees) shall fall under a modified program whereby compensation for possession of certificates shall be as follows: Intermediate POST certificate - \$200/month; Bachelor's degree or Advanced POST certificate – \$200/month; Master's degree or Supervisor's POST certificate - \$300/month. An employee who possesses more than one of the degrees or certificates above shall receive the pay for each degree or certificate possessed. (Example: An employee with a Bachelor's degree and an Intermediate POST certificate shall be paid \$400/month. If the employee also had a Master's degree the employee would be paid \$700/month).

- iii. Effective January 1, 2012, new Certificates presented for processing shall be paid effective from the date officially received by the Personnel Office. Transcripts shall not be accepted in lieu of eligible certificates or degrees.

(9) **Holiday Hours**

Unit members shall be granted the following holidays:

- | | |
|--------------------------------------|-----------------------|
| (1) New Year's Day | (7) Independence Day |
| (2) Martin Luther King, Jr. Birthday | (8) Labor Day |
| (3) Lincoln's Birthday | (9) Columbus Day |
| (4) Washington's Birthday | (10) Veteran's Day |
| (5) Cesar Chavez's Birthday | (11) Thanksgiving Day |
| (6) Memorial Day | (12) Christmas Day |

Employees shall accrue 96 hours of holiday leave per year, and shall be credited with 48 hours of holiday leave each January 1 and additional 48 hours of holiday leave each July 1. Employees shall schedule holiday leave in accordance with department procedures.

Employees will only be permitted to carry over 96 hours of accrued but unused holiday leave from one calendar year to the next. Employees who, as of January 1, have not lowered their accrued holiday leave to 96 hours or less, shall not accrue additional hours until such time as the employee brings his/her accrual to (or under) the 96 hours cap. At that time, the employee will receive his/her full 48 hours allotment for that half-year. Upon employee's separation, any unused holiday leave shall be compensated at his or her regular rate of pay.

(10) **Uniform Allowance**

The City shall pay employees a uniform allowance of \$800 per year. The allowance may be paid in equal semi-annual installments.

(11) **Overtime**

Employees shall receive time and one-half their regular rate of pay for all hours worked in excess of their regularly scheduled hours. In the event an employee takes sick leave on a regularly scheduled workday, and works beyond his/her regularly scheduled hours on that day, then the employee shall receive straight time compensation for the work beyond their regular schedule up to the duration of the sick leave used that day. Thereafter, all work beyond their regularly scheduled hours shall be compensated at the time and one-half rate. Employees may elect to be paid for overtime hours worked or receive compensatory time off, but in no event shall their compensatory time bank exceed 100 hours.

(12) **Compensatory Time Off**

Employees are permitted to accrue up to one hundred (100) hours of compensatory time off at any given time. Compensatory time off is accrued at one and one-half hours for each hour of overtime worked. An employee will be allowed to use accrued but unused compensatory time off in compliance with the requirements of the FLSA.

(13) **Call Back Compensation**

Any employee called back to work other than as a continuation (immediately preceding or following) of his/her regular established work schedule, shall be paid at one and one-half (1½) times the regular rate of pay for the actual time worked, with a minimum of two (2) hours.

(14) **On-Call/Stand-By for Court**

Any employee required to be on-call for court during off-duty hours, shall be paid at one and one-half (1½) times his/her regular rate of pay for two (2) hours for the morning session and two (2) hours for the afternoon session. If an employee is placed on-call for court and is subsequently called to testify during that same court session, the employee shall be paid for the combined duration of the actual time spent on-call and the actual time spent in the court appearance, at time and one-half his/her regular rate of pay, with a minimum of two hours.

(15) **Court Appearance Pay**

Any employee required to appear in court during off-duty hours, shall be paid at one and one-half (1½) times his/her regular rate of pay for the duration of the court appearance, with a minimum of two (2) hours.

(16) **Out of Class Pay**

Any unit member appointed to act in a higher classification and serving continuously in said classification for at least fifteen (15) continuous working days shall receive the pay established for said higher classification during the acting period, retroactive to the first day of said assignment.

(17) **Pre-Employment Contract**

Any employee hired after July 1, 2008 who voluntarily leaves the City within thirty-six (36) months of accepting employment as a police cadet or police officer, and who obtains employment as a police officer within the State of California within the subsequent 12 months, will be required to repay the City for the actual cost of training that employee, not to exceed \$450 per month for each month short of 36. Said payments may be accomplished by relinquishing accrued but unused Vacation leave, Holiday leave or CTO leave, or in monthly installments of \$450, or both, at the employee's option.

(18) **Other Benefits**

For other benefits such as medical, dental, vision insurance, and retirement, that apply to Schedule P, please refer to their specific MOU (Contract No. 1789).

(D) POLICE MANAGEMENT UNIT

Salaries and benefits listed here apply to regular full time employees assigned to **Schedule MP**, for Sworn Police Lieutenants, and reflect stipulations in the last approved MOU.

(1) **Salary**

The salary ranges shown under **Schedule MP** reflects the following, per the last approved MOU:

- In order to create equitable separation between the Lieutenant classification and the classification immediately preceding Lieutenant, i.e. Sergeant, "Step A" in the Lieutenant classification was increased by ten percent (10%), and each subsequent Step was adjusted accordingly, effective the first pay period beginning after July 1, 2015.
- Effective on the first day of the pay period beginning after July 1, 2015, the base salary for each represented unit classification was increased by one percent (1%).

In computing benefits that are a percentage of base salary (e.g., Longevity, Bilingual, Special Assignment Pay, Post Certificate/Education, etc.) each benefit is calculated independently over the base salary of each respective employee.

(2) **Annual Leave**

Employees earn Annual Leave in lieu of Vacation and Sick Leave. Annual Leave is intended to provide time for an employee to be away from the work environment and to enable such employee to return to work mentally and physically refreshed.

The City shall provide for Annual Leave to accrue on a payroll basis prorated in accordance with the following rates:

160 hours for 1-5 years of City service
200 hours for 6-10 year of City service
240 hours for 11 or more years of City service

Annual Leave may be taken upon prior approval and in the manner prescribed by the Police Chief or his/her designee.

Unit members may, at the employee's discretion, accrue up to 800 hours of Annual Leave. Upon the employee's separation from City service, the employee shall be compensated for any unused Annual Leave at his or her regular rate of pay.

In the last payroll period in December each year, unit members may, at the employee's discretion, receive compensation for up to 80 hours of accumulated Annual Leave at their regular rate of pay provided that the employee has used a like number of hours of Annual or Management Leave during the same calendar year.

(3) **Management Leave**

Management Leave, also known as Administrative Leave, is intended to allow the employee time to manage personal affairs as required. Management Leave also provides a means of compensation for hours worked by exempt employees beyond their normal work schedule.

The City shall provide 80 hours Management Leave per year, credited January 1st of each year. Management Leave must be used in the year earned, and cannot be carried over from one calendar year to the next.

(4) **Bereavement Leave**

Employees shall be permitted to use up to five (5) days of any type of accrued leave per incident for bereavement purposes. The Police Chief may authorize additional days of leave for bereavement purposes on an as-needed basis.

(5) **Longevity Pay**

For unit employees hired prior to January 1, 2012:

The City shall pay longevity to all eligible unit members as follows:

- a) Upon completion of the fifth year of continuous service as a sworn employee with the City, an additional five percent (5%) over and above the base salary step for each employee in this category.
- b) Upon completion of the tenth year of continuous service as a sworn employee with the City, a total of seven and one-half percent (7½%) over and above the base salary step for each employee in this category.
- c) Upon completion of the fifteenth year of continuous service as a sworn employee with the City, a total of ten percent (10%) over and above the base salary step for each employee in this category.

For unit employees hired on or after January 1, 2012:

The City shall pay longevity to all eligible unit members as follows:

- a) Upon completion of the fifth year of continuous service as a sworn employee with the City, an additional three percent (3%) over and above the base salary step for each employee in this category.
- b) Upon completion of the tenth year of continuous service as a sworn employee with the City, a total of four percent (4%) over and above the base salary step for each employee in this category.
- c) Upon completion of the fifteenth year of continuous service as a sworn employee with the City, a total of five percent (5%) over and above the base salary step for each employee in this category.

(6) Bilingual Pay

The City shall pay a bilingual bonus of a flat \$100 per month to unit employees required in the normal course of their duties to communicate in Spanish with members of the public. Said payment is subject to the following conditions:

- a) Employee has satisfactorily demonstrated to the City his/her fluency in the Spanish language, based on written and/or oral testing procedures as selected by the City; and
- b) Employee is required in the normal course of his/her duties to communicate in Spanish with members of the public, as determined by the department head and approved in writing by the City Manager.

(7) POST Certificate Compensation

Unit employees who possess any of these certificates shall be compensated as follows over that employee's base salary:

Cert/Degree/Units	Before 1/1/12	Effective 1/1/12
Intermediate POST or AA/AS degree	\$285/Month	\$200/Month
Advanced POST or BA/BS degree	Add'l \$204/Month	Add'l \$200/Month
Supervisory POST or Master's degree	Add'l \$204/Month	Add'l \$300/Month

b) The following shall apply:

- i. Any employee that was receiving Certificate/Education pay for possession of any degree or certificate shall continue to fall under the provisions of the current program, provided, however, compensation for possession of an Associate degree will be eliminated, except as to employees hired before 1/1/12, who were “grandfathered”.
- ii. Effective January 1, 2012, any employee not receiving any form of Certificate Pay (inclusive of certificates, units or degrees) shall fall under a modified program whereby compensation for possession of certificates shall be as follows: Intermediate POST certificate - \$200/month; Bachelor’s degree or Advanced POST certificate – \$200/month; Master’s degree or Supervisor’s POST certificate - \$300/month. An employee who possesses more than one of the degrees or certificates above shall receive the pay for each degree or certificate possessed. (Example: An employee with a Bachelor’s degree and an Intermediate POST certificate shall be paid \$400/month. If the employee also had a Master’s degree the employee would be paid \$700/month).
- iii. Effective January 1, 2012, new Certificates presented for processing shall be paid effective from the date officially received by the Personnel Office. Transcripts shall not be accepted in lieu of eligible certificates or degrees.

(8) **Uniform Allowance**

Uniform allowance for Police Lieutenants shall be \$800 per year, payable in equal semi-annual installments.

(9) **Out of Class Pay**

Any unit member appointed to act in a higher classification and serving continuously in said classification for at least fifteen (15) continuous working days shall receive the pay established for said higher classification during the acting period, retroactive to the first day of said assignment.

(10) **Contract Duty**

Unit members who, at the employee’s discretion, work special assignments, typically referred to as “Contract Duty” shall be compensated on an hourly basis for all contract duty worked at one and one-half times the “Top Step” base pay of a City Police Sergeant plus any longevity and certificate pay to which the employee is entitled.

(11) **Vehicles**

Unit members shall be assigned an unmarked multi-purpose police vehicle for use to and from work locations and for official City business in accordance with City policy.

(12) **Other Benefits**

For other benefits such as medical, dental, vision insurance, and retirement, that apply to Schedule MP, please refer to their specific MOU (Contract No. 1793).

(E) **POLICE CHIEF**

For the Police Chief, the following shall apply, but can change contingent upon negotiated agreement between the Chief and the City:

- (1) **Salary**
The salary shown for Police Chief in this salary schedule reflects a Flat Rate for the 2015-2016 Fiscal Year. Subsequent increases shall be based on negotiated agreement between the Chief and the City.
- (2) **Longevity Pay**
The City shall pay the Police Chief an additional ten percent (10%) longevity pay over and above the monthly base salary.
- (3) **Annual Leave**
Annual Leave for the Police Chief shall accrue on a payroll to payroll basis, and prorated in accordance with the following rates:

160 hours or 20 days for 1-5 years of City service
200 hours or 25 days for 6-10 year of City service
240 hours or 30 days for 11 or more years of City service

Annual Leave may be taken upon prior approval and in the manner prescribed by the City Manager. If the employee's accrued but unused Annual Leave reaches 800 hours total, he or she will stop accruing additional Annual Leave unless and until the accrued Annual Leave falls below 800 hours.

In the last payroll period in December each year, the Chief may, at the employee's discretion, receive compensation for up to 80 hours of accumulated Annual Leave at his or her regular rate of pay provided that the employee has used a like number of hours of Annual or Management Leave during the same calendar year.

If the employee has pre-existing Sick Leave and/or Vacation accrual balance, he shall convert each hour of Sick Leave to 0.5 hours of Annual Leave; and convert Annual Leave at the rate of one (1) hour of Vacation to one (1) hour of Annual Leave. Upon the employee's separation from City service, the employee shall be compensated for any unused Annual Leave at his or her regular rate of pay.

- (4) **Management Leave**
The Police Chief shall receive a maximum of eighty (80) hours of Management Leave per year, credited January 1st of each year. Management Leave must be used in the year earned and cannot be carried over from one calendar year to the next. Employee shall schedule Management Leave upon prior approval, and in the manner prescribed by the City Manager.
- (5) **Holidays**
The Police Chief shall receive twelve (12) paid holidays similar to all sworn police employees, and in accordance with the City's current practices. Paid holidays will be those approved by the City by action of the City Council. The employee shall accrue 96 hours of Holiday Leave per year, and shall be credited with 48 hours of holiday leave each January 1, and additional 48 hours of holiday leave each July 1. The employee shall schedule Holiday Leave upon prior approval, and in the manner prescribed by the City Manager.

(6) **Uniform Allowance**

Uniform allowance for the Police Chief shall be \$800 per year, and shall be paid in equal semi-annual installments.

(7) **Use of City-Owned Automobile**

The Police Chief shall be assigned an unmarked multi-purpose police vehicle for use to and from work locations and for official City business in accordance with City policy.

(F) DEPARTMENT HEADS AND MANAGEMENT

Salaries and benefits listed here apply to regular full-time, non-sworn department heads and management employees assigned to **Schedule M**, and reflect stipulations in the last MOU/Resolution. These stipulations may change, and are contingent upon negotiation of a new MOU/Resolution.

(1) **Salary**

a) For full-time, non-sworn department heads, the salary ranges shown under **Schedule M** reflect the following, per Resolution No. 7692:

- 0% COLA for Fiscal Year 2015-2016

b) For full-time, non-sworn management employees, the salary ranges shown under **Schedule M** reflects the following, per the last approved MOU (Contract No. 1796):

- Effective on the first day of the pay period beginning after July 1, 2015, the base salary for each represented unit classification was increased by two percent (2%).

In computing benefits that are a percentage of base salary (e.g., longevity, bilingual, etc.) each benefit is calculated independently over the base salary of each respective employee.

(2) **Bilingual Pay**

The City shall pay \$100.00 per month bilingual bonus for unit employees required in the normal course of their duties to communicate in Spanish with members of the public. Said payment is subject to the following conditions:

- a) The employee has demonstrated to the satisfaction of the City his/her fluency in the Spanish language based on an oral testing procedure selected by the City; and
- b) The employee is required in the normal course of his/her duties to communicate in Spanish with members of the public, as determined by the Department Head and approved in writing by the City Manager.

(3) **Annual Leave**

a) Unit employees shall be entitled to 100% of their annual leave accrual balance to be received in compensation at termination or separation.

b) Annual Leave accrual per pay period for all unit members is as follows: 0 – 5 years of service: 6.15 Hours; 5 – 9 years of service: 7.69 Hours; and 10 or more years of service: 9.23 Hours.

c) Employees who have pre-existing Sick Leave and/or Vacation accrual balance shall convert Sick Leave to Annual Leave at the rate of One (1) Hour of Sick Leave to 0.5 Hours of Annual Leave; and convert Vacation to Annual Leave at the rate of One (1) Hour of Vacation to One (1) Hour of Annual Leave.

(4) **Management Leave**

The City shall grant full-time, non-sworn department heads 120 hours of management leave per calendar year, to be credited each January 1. Up to 120 hours of any unused leave will be cashed out in December of each year. At the time of separation, any unused management leave hours will be paid at the current rate of pay.

For full-time, non-sworn management employees, the City shall grant 80 hours of management leave per calendar year, to be credited each January 1. Up to 80 hours of any unused leave will be cashed out in December of each year. At the time of separation, any unused management leave hours will be paid at the current rate of pay.

(5) **Acting Pay**

Employees who by written assignment perform the duties of a position with a higher salary classification than that in which they are regularly employed shall receive the compensation specified for the position to which assigned, if performing the duties thereof for a period of fifteen (15) or more consecutive work days. The increased compensation shall be at the step within the higher classification as will accord the employee an increase of at least 5% of his or her current regular compensation.

(6) **Longevity Pay**

Regular full-time, non-sworn department heads and management employees shall receive longevity pay as follows:

- a) Unit employees that have completed 10 years of service from date of hire, an additional 3% above the base salary step for each employee.
- b) Unit employees that have completed 20 years of service from date of hire, a total of 4% over and above the base salary.
- c) Unit employees that have completed 30 years of service from date of hire, a total of 5% over and above the base salary.

Any unit employee on leave of absence without pay with the exception of Family & Medical Leave (FMLA), shall not have such leave time credited as service time for purposes of calculating the years of service.

(7) **Car Allowance**

Full-time, non-sworn department heads will receive a City-provided vehicle or car allowance of \$300/month as compensation for attendance at off-site meetings, conferences, professional development, and any other business-related travel. Department heads receiving a City-provided vehicle or car allowance will not be reimbursed for mileage.

(8) **Mileage Reimbursement**

Full-time, non-sworn management employees who are required by the City to use their private vehicles for City business shall be reimbursed for mileage at the prevailing IRS rate.

(9) **Tuition Reimbursement**

The City shall reimburse regular full-time, non-sworn department heads and management employees for pre-approved courses to a maximum of \$3,000 per fiscal year. Approval must be obtained from the City Manager prior to enrolling in the course. Requests for reimbursement and approval must be in accordance with the City's policy on tuition reimbursement.

Tuition reimbursement shall be contingent upon employee satisfactorily completing course(s) with a minimum of a "B" grade, and commit to continued service (employment) to the City of San Fernando for the equivalent of the school units, not to exceed two years.

(10) **Technology Reimbursement**

Full-time, non-sworn department heads may elect to receive a technology reimbursement of \$100/month in lieu of a City-issued cell phone. Department heads that continue to receive a City-issued phone will not receive the reimbursement.

(11) **Other Benefits**

For other benefits such as medical, dental, vision insurance, and retirement, that apply to Schedule M, please refer to Council Resolution No. 7692 (for Department Heads), and MOU (Contract No. 1796) for SFMG.

(G) CITY CLERK

For the City Clerk position, the salary shown reflects a Flat Rate for the 2015-2016 Fiscal Year, as per Contract No. 1804, and can change contingent upon negotiation.

For other benefits, including but not limited to, medical, dental, vision insurance, and retirement, please refer to Contract No. 1804.

(H) CITY MANAGER

For the City Manager position, the following shall apply, but can change contingent upon negotiated contract:

(1) **Salary**

The salary shown for the City Manager in this salary schedule reflects a Flat Rate for the 2015-2016 Fiscal Year, as per Contract No. 1737. Subsequent increases shall be based on negotiated agreement between the City Manager and the City.

(2) **Bilingual Pay**

The City Manager shall be entitled to receive a bilingual bonus of \$100 per month if eligible per specified City policies and guidelines.

(3) **Annual Leave**

The City Manager shall accrue Annual Leave at a rate of ten (10) hours of Annual Leave per month for a total of one hundred and twenty (120) hours or fifteen (15) business days of Vacation Leave per calendar year. However, the City Manager cannot accrue additional

Annual Leave during any period of time in which his total bank of Annual Leave exceeds three hundred (300) hours total.

(4) **Sick Leave**

The City Manager shall accrue Sick Leave at a rate of eight (8) hours of Sick Leave per month for a total of ninety six (96) hours or twelve (12) business days of Sick Leave per calendar year. Sick Leave shall be used only in cases of actual sickness or disability of the employee or the employee's immediate family or dependents.

(5) **Maximum Annual Leave Accrual**

At no time shall the employee accrue more than eight hundred (800) hours or one hundred (100) business days of total Annual Leave, including both Vacation and Sick Leave ("Annual Leave"). The employee shall cease to accrue any additional Annual leave time so long as his total accrued but unused Annual Leave remains at 800 hours or 100 business days total.

Per Government Code Section 53243 or other applicable law, upon voluntary or involuntary separation from the City, the employee may cash-out the unused balance of his total accrued Annual Leave. The cash-out shall be in an amount equal to the total number of unused Annual Leave hours multiplied by the quotient of the employee's annual base salary at the time of separation divided by two thousand eighty (2080) hours.

(6) **Management Leave**

The City Manager shall be granted one hundred and twenty (120) hours or fifteen (15) business days of Management Leave per year, accrued in the same manner as all other regular non-sworn management employees.

(7) **Holidays**

The City Manager shall receive paid holidays in accordance with the City's current practices. Paid holidays will be those approved by the City by action of the City Council. The City currently provides twelve (12) paid holidays per calendar year.

(8) **Automobile Allowance**

The City shall provide the City Manager with an automobile allowance in the amount of Four Hundred Dollars (\$400) per month to assist the City Manager with the cost of using and operating his own private vehicle and to offset expenses such as gasoline, auto insurance, maintenance, repair, and other automobile related costs and expenses.

(9) **Medical, Dental and Vision Insurance**

The City Manager shall receive any and all employee medical, dental, and vision insurance benefits otherwise accorded the City's executive management employees (department heads).

(10) **Other Benefits**

For other benefits such as severance pay and retirement that apply to the City Manager, please refer to Contract No. 1737 and applicable amendments.

(I) **CITY COUNCIL**

In addition to the compensation reported under Section 2 (D) above, members of the City Council shall also receive the following benefits:

(1) **Automobile Allowance**

The City shall provide City Council members with an automobile allowance in the amount of Three Hundred Dollars (\$300) per month to assist the members with the cost of using and operating their own private vehicle, and to offset expenses such as gasoline, auto insurance, maintenance, repair, and other automobile related costs and expenses.

(2) **Medical, Dental and Vision Insurance**

City Council members shall receive any and all employee medical, dental, and vision insurance benefits otherwise accorded the City's executive management employees (department heads). However, where a fixed Cafeteria Plan allotment is accorded for purchase of medical, dental, and vision insurance, and the Council member does not spend his or her entire allotment, the balance shall be placed into a deferred compensation plan (Section 457 Plan) maintained by the City.

(3) **Retirement**

City Council members shall be entitled to retirement benefits, as per the stipulations of the State of California Public Employees' Retirement Laws.

(4) **Technology Reimbursement**

City Council members may elect to receive a technology reimbursement of \$100/month in lieu of a City-issued cell phone. Members that elect to receive a City-issued phone will not receive the reimbursement.

(5) **Wellness Reimbursement**

The City shall reimburse City Council members up to annual maximum of \$600 for reimbursable "wellness" expenses specifically incurred for health and welfare to the extent defined and permitted by Government Code, Section 53200(d). Medical exams, uninsured medical care costs, vision and dental expenses may qualify as health and welfare benefits. However, health club/fitness center membership, registration fees for health classes, and entrance fees for competitive events shall not qualify as health and welfare benefits.

SECTION 4: EMPLOYEES PLACED IN SAME STEP

For the purpose of placing this Resolution in effect as of the first day of the first pay period that includes December 1, 2015 and for the purpose of interpretation, each employee shall be placed in that salary step which he or she presently occupies in the range set forth for said position.

SECTION 5: INTERPRETATION - INEQUITY

In case of an inequity of hardship affecting any employee in a particular classification by reason of the adoption of this Resolution, the Council may adjust the same and the Council's action thereon as entered on the minutes shall be final. The Council shall determine all matters of interpretation of this Resolution and placement of employees in the proper salary steps and classification, and Council's decision on such matters as entered on the minutes shall be final.

SECTION 6: INTENT OF COUNCIL

It is the specific intent of the City Council that all officers and employees of the City for whom a salary range is specified in this Resolution or any amendment hereto shall be governed by the provision of this Resolution.

SECTION 7: REPEAL

Resolution No. 7680, adopted June 15, 2015, all Resolutions amendatory thereof or in conflict herewith and all motions and actions of the City Council in conflict herewith or covering the same matters heretofore adopted or taken to be the same are hereby repealed.

SECTION 8: EFFECTIVE DATE

The City Clerk shall certify to the passage of this Resolution, and the same shall be in full force and effect as of the first day of the first pay period that includes December 1, 2015.

ADOPTED AND APPROVED this 7th day of December, 2015.

Joel Fajardo, Mayor

ATTEST:

Elena G. Chávez, City Clerk

STATE OF CALIFORNIA)
COUNTY OF LOS ANGELES) ss
CITY OF SAN FERNANDO)

I HEREBY CERTIFY that the foregoing Resolution was approved and adopted at a regular meeting of the City Council held on the 7th day of December, 2015, by the following vote to wit:

AYES:

NOES:

ABSENT:

Elena G. Chávez, City Clerk

ATTACHMENT "B"**RESOLUTION NO. 7717**

A RESOLUTION OF THE CITY COUNCIL OF THE CITY OF SAN FERNANDO AMENDING THE TABLE OF ORGANIZATION FOR THE 2015-2016 FISCAL YEAR AND REPEALING PORTIONS OF SECTION 1 OF RESOLUTION NO. 7681, ADOPTED JUNE 15, 2015, AND ALL RESOLUTIONS AMENDATORY THEREOF, AND ALL MOTIONS OF THE CITY COUNCIL IN CONFLICT HERewith.

WHEREAS, the City Council of the City of San Fernando adopted the Fiscal Year 2015-2016 Budget on June 15, 2015; and

WHEREAS, the Budget adopted for Fiscal Year 2015-2016 has provisions for various positions and classifications;

WHEREAS, it is necessary that said positions be assigned to specific departments, divisions and activities by title and number; and

WHEREAS, the City Council adopted new Memorandum of Understanding (MOU) with various employee bargaining units for Fiscal Year 2015-2016 that impacted the assignment of certain positions and classifications; and

WHEREAS, it is necessary that a new Table of Organization be adopted to reflect the positions assigned to specific departments, divisions, and activities by title and number;

NOW, THEREFORE, THE CITY COUNCIL OF THE CITY OF SAN FERNANDO DOES HEREBY RESOLVE, FIND DETERMINE, AND ORDER AS FOLLOWS:

SECTION 1: That that portion of the said Table of Organization adopted on June 15, 2015, per Resolution No. 7681, and all Resolutions amendatory thereof, be repealed, and that a new Table of Organization be added assigning the positions to the departments, divisions and activities as herein designated per attached Exhibit "A".

SECTION 2: Except as amended herein, all other provisions of the said Table of Organization adopted on June 15, 2015, per Resolution No. 7681, remains unchanged and in full force and effect.

SECTION 3: The City Clerk shall certify to the adoption of this Resolution and shall cause this Resolution and her certification to be filed in the office of the City Clerk.

PASSED, APPROVED, AND ADOPTED this 7th day of December, 2015.

Joel Fajardo, Mayor

ATTEST:

Elena G. Chavez, City Clerk

STATE OF CALIFORNIA)
COUNTY OF LOS ANGELES) **ss**
CITY OF SAN FERNANDO)

I HEREBY CERTIFY that the foregoing Resolution was approved and adopted at a regular meeting of the City Council held on the 7th day of December, 2015, by the following roll call vote to wit:

AYES:

NOES:

ABSENT:

Elena G. Chavez, City Clerk

Exhibit "A"			
CITY OF SAN FERNANDO FY 2015-2016 - TABLE OF ORGANIZATION			
<u>DEPARTMENT/TITLE</u>	BUDGETED HOURS (PER WEEK)	FULL TIME EQUIVALENT (FTE) STATUS	AVG NUMBER OF PERSONNEL IN POSITION
<u>ADMINISTRATION</u>			
City Manager	40	1	1
Executive Assistant to the City Manager	40	1	1
TOTAL	80	2	2
City Clerk	40	1	1
Deputy City Clerk (P/T)	20	0.5	1
TOTAL	60	1.5	2
<u>Personnel Division</u>			
Personnel Manager	40	1	1
Personnel Technician	40	1	1
TOTAL	80	2	2
<u>COMMUNITY DEVELOPMENT</u>			
Community Development Director	40	1	1
Community Preservation Officer	80	2	2
Building & Safety Supervisor	40	1	1
Associate Planner	40	1	1
Community Development Secretary	40	1	1
Community Preservation Officer (P/T)	30	0.75	2
City Maintenance Helper (P/T) - Grafitti	38	0.95	2
TOTAL	308	7.7	10
<u>FINANCE</u>			
Finance Director	40	1	1
Junior Accountant	40	1	1
Senior Account Clerk II	40	1	1
Senior Account Clerk	80	2	2
Finance Office Specialist	40	1	1
Cashier (P/T)	40	1	2
TOTAL	280	7	8
<u>POLICE</u>			
Police Chief	40	1	1
Police Lieutenant	80	2	2
Police Sergeant	200	5	5
Police Officer	920	23	23
Police Desk Officer	320	8	8
Police Office Specialist	40	1	1
Police Records/Systems Administrator	40	1	1

Exhibit "A"

**CITY OF SAN FERNANDO
FY 2015-2016 - TABLE OF ORGANIZATION**

<u>DEPARTMENT/TITLE</u>	<u>BUDGETED HOURS (PER WEEK)</u>	<u>FULL TIME EQUIVALENT (FTE) STATUS</u>	<u>AVG NUMBER OF PERSONNEL IN POSITION</u>
<u>POLICE (Continued)</u>			
Police Records Specialist	40	1	1
Property Control Officer	40	1	1
Community Service Officer (P/T)	80	4	4
Crossing Guard (P/T)	100	2.5	6
Junior Cadet (P/T)	40	1	2
TOTAL	1940	50.5	55
<u>PUBLIC WORKS</u>			
Deputy City Manager/Public Works Director	40	1	1
Management Analyst	40	1	1
Office Specialist	40	1	1
Public Works Administrative Coordinator	40	1	1
Public Works Office Specialist	40	1	1
<u>Electrical Division</u>			
Electrical Supervisor	40	1	1
Building Maint. Worker/Electrical Helper	40	1	1
<u>Engineering Division</u>			
Civil Engineering Assistant II	80	2	2
<u>Facility Maintenance Division</u>			
Public Works Superintendent	40	1	1
Public Work Field Supervisor II	40	1	1
Senior Maintenance Worker	40	1	1
Public Works Maintenance Worker	120	3	3
Public Works Maintenance Helper (P/T)	57	1.4	4
<u>Equipment Maintenance Division</u>			
Equipment & Materials Supervisor	40	1	1
Mechanical Helper	40	1	1
<u>Street Services Division</u>			
Public Works Supervisor II	40	1	1
Senior Maintenance Worker	160	4	4
Public Works Maintenance Worker	80	2	2
Public Works Maintenance Worker (P/T)	17	0.4	1

Exhibit "A"

**CITY OF SAN FERNANDO
FY 2015-2016 - TABLE OF ORGANIZATION**

<u>DEPARTMENT/TITLE</u>	<u>BUDGETED HOURS (PER WEEK)</u>	<u>FULL TIME EQUIVALENT (FTE) STATUS</u>	<u>AVG NUMBER OF PERSONNEL IN POSITION</u>
<u>PUBLIC WORKS (Continued)</u>			
<u>Water Services Division</u>			
Public Works Superintendent	40	1	1
Public Works Field Supervisor II	40	1	1
Public Works Field Supervisor I	40	1	1
Senior Maintenance Worker	40	1	1
Public Works Maintenance Worker	80	2	2
Meter Technician	40	1	1
Water Pumping Operator/Backflow Techn.	40	1	1
TOTAL	1354	33.8	37
<u>RECREATION & COMMUNITY SERVICES</u>			
Director of Rec. & Community Services	40	1	1
Office Specialist	80	2	2
Community Services Supervisor	40	1	1
Cultural Arts Supervisor	40	1	1
Recreation Supervisor	40	1	1
Program Specialist	40	1	1
Day Camp/After School Counselor (P/T)	262	7	14
Cashier (P/T)	12	0.3	3
Program Specialist (P/T)	40	1	2
Recreation Leader I, II & III (P/T)	255	6.38	20
Senior Day Camp/Senior After School Counselor (P/T)	101	2.53	7
TOTAL	950	24.21	53
<u>TREASURER</u>			
Treasurer Assistant	40	1	1
Office Clerk	40	1	1
TOTAL	80	2	2
GRAND TOTAL FULL TIME	5132	130.71	171

*This Page
Intentionally
Left Blank*

*This Page
Intentionally
Left Blank*

ORDINANCE NO. 1648

AN ORDINANCE OF THE CITY COUNCIL OF THE CITY OF SAN FERNANDO AMENDING DIVISION I (GENERALLY) OF ARTICLE V (BOARDS, COMMISSIONS, COMMITTEES, AGENCIES, AND AUTHORITIES) OF CHAPTER 2 (ADMINISTRATION) REGARDING THE APPOINTMENT, REMOVAL, AND RULES OF DECORUM FOR CITY COMMISSIONERS

RECITALS

WHEREAS, the City Council of the city of San Fernando (the “City Council” of the “City”) has broad authority to appoint boards and commissions as part of the sub-government of the City; and

WHEREAS, appointed members of boards and commissions serve at the pleasure of the City Council, pursuant to Government Code Section 36506; and

WHEREAS, the City Council seeks to augment regulations concerning the removal of commissioners and board members appointed by the City Council and establish rules of decorum applicable to such commissioners and board members; and

WHEREAS, such new regulations and rules shall supplement the existing regulations set forth in Division 1 (Generally) of Article II (City Council) of Chapter 2 (Administration) of the San Fernando Municipal Code, which shall be transferred to that portion of the San Fernando Municipal Code concerning City commissions and similar bodies in order to facilitate the logical and orderly organization of the San Fernando Municipal Code.

NOW, THEREFORE, THE CITY COUNCIL OF THE CITY OF SAN FERNANDO, CALIFORNIA DOES HEREBY ORDAIN AS FOLLOWS:

SECTION 1. The facts set forth in the recitals above are true and correct.

SECTION 2. Division 1 (Generally) of Article II (City Council) of Chapter 2 (Administration) of the San Fernando Municipal Code is amended by the deletion of Section 2-33, Section 2-34, Section 2-35, and Section 2-36, which shall become reserved.

SECTION 3. Reserved Division 1 (Generally) of Article V (Boards, Commissions, Committees, Agencies and Authorities) of Chapter 2 (Administration) of the San Fernando Municipal Code shall hereby read as follows:

Division 1 – Generally

Sec. 2-401 Appointment of city commissioners.

Sec. 2-402 Method of appointment to commissions.

Sec. 2-403 Removal of commission members; vacancies.**Sec. 2-404 Term of commissioners.****Sec. 2-405 Rules of decorum for commissions.**

Sec. 2-401 Appointment of city commissioners.

- (a) The city council shall have the authority to appoint individuals to city commissions.
- (b) Appointed members of boards and commissions serve at the pleasure of the city council, pursuant to Government Code Section 36506.
- (c) For purposes of this Division 1, “commissions” shall include, but not be limited to, city commissions, boards, committees, and other bodies comprised of members appointed by the city council.

Sec. 2-402 Method of appointment to commissions.

Unless otherwise specified in this code, each city councilmember will be assigned a position that will correlate to a position on each commission. That councilmember will have the authority to nominate an individual to serve in the assigned position on the commission. Each such nomination shall require ratification by a majority of the city council.

Sec. 2-403 Removal of commission members; vacancies.

- (a) All commissioners serve at the pleasure of the City Council and any commissioner may be removed, with or without cause, either by a majority of the entire membership of the city council or by the councilmember who individually appointed such commissioner.
- (b) If vacancies in any commission occur, other than by expiration of the term, such vacancies shall be filled by appointment for the unexpired portion of the term. The city council member who nominated the vacating commission member shall nominate a replacement commissioner, subject to ratification by a majority of the city council.

Sec. 2-404 Term of commissioners.

The term of office for each commission member shall be one year; however, each member shall continue in the position beyond one year until replaced by the assigned city councilmember or until the member resigns.

Sec. 2-405 Rules of decorum for commissions.

- (a) Decorum and order – commissioners.

- (1) Commissioners shall accord the utmost courtesy to each other, to city employees, and to the public appearing before the commission and shall refrain at all times from rude and derogatory remarks, reflections as to integrity, abusive comments, and statements as to motives and personalities.
 - (2) Every commissioner desiring to speak shall address the chair of the commission and, upon recognition by such chair, shall confine discussion to the question under debate.
 - (3) Every commissioner desiring to question administrative staff should address questions to the city manager who may answer the inquiry directly or designate the appropriate staff member to timely respond to such inquiry.
 - (4) A commissioner, once recognized, shall not be interrupted while speaking, unless called to order by the chair of the commission, or a point of order is raised by another commissioner, or the speaker chooses to yield to questions from another commissioner.
 - (5) Any commissioner may move to require the chair of the commission to enforce the rules. A majority of the commission shall require enforcement of the rules if the chair of the commission has refused.
- (b) Decorum and order – employees. Members of administrative staff and city employees shall observe the same rules of procedure and decorum applicable to members of commissions. The city manager shall ensure that all city employees observe such decorum. Any staff member, including the city manager, desiring to address the commission or members of the public shall first be recognized by the chair of the commission. All remarks should be addressed to the chair of the commission and not to any one individual commissioner or member of the public.
- (c) Decorum and order – public. Members of the public attending commission meetings shall observe the same rules of order and decorum applicable to the commission. Each person who addresses the commission shall not make personal, impertinent, slanderous or profane remarks to any member of the commission, staff or general public. Any person who makes such remarks, or who utters loud, threatening, personal or abusive language, or engages in any other disorderly conduct which disrupts, disturbs or otherwise impedes the orderly conduct of the commission meeting shall, at the discretion of the chair of the commission or a majority of the commission, be barred from further audience before commission during that meeting.
- (d) Personal interest. No commissioner disqualified from participation under state or local law shall remain at the commission dais during the debate or vote on such matter. The commissioner shall publicly state the grounds for disqualification on the record and, upon acceptance by the chair of the commission, leave the dais during the debate or vote on the issue.
- (e) Limitations on debate. No commissioner shall be allowed to speak more than once upon any one subject until every commissioner choosing to speak has spoken. Merely asking a question, or making a suggestion, is not considered speaking.

- (f) Dissents and protests. Any commissioner shall have the right to express dissent from, or protest to, any action of the commission and request that the reason be entered into the minutes.
- (g) Procedures in absence of rules. In the absence of a rule to govern a point or procedure, Robert's Rules of Order shall govern.

SECTION 4. Inconsistent Provisions. Any provision of the San Fernando Municipal Code or appendices thereto that conflicts with the provisions of this Ordinance, to the extent of such conflict and no further, is hereby repealed or modified to the extent necessary to affect the provisions of this Ordinance.

SECTION 5. Severability. If any section, subsection, subdivision, paragraph, sentence, clause or phrase of this Ordinance, or any part thereof is for any reason held to be invalid or unconstitutional by a decision of any court of competent jurisdiction, such decision shall not affect the validity of the remaining portions of this Ordinance or any part thereof. The City Council hereby declares that it would have passed each section, subsection, subdivision, paragraph, sentence, clause or phrase thereof, irrespective of the fact that any one or more section, subsection, subdivision, paragraph, sentence, clause or phrase would be subsequently declared invalid or unconstitutional.

SECTION 6. Publication. The Mayor shall sign and the City Clerk shall attest to the passage of this Ordinance. The City Clerk shall cause the same to be published once in the official newspaper within fifteen (15) days after its adoption. This Ordinance shall become effective thirty (30) days after adoption.

PASSED, APPROVED, AND ADOPTED by the City Council of the City of San Fernando at its regular meeting on this 7th of December, 2015.

Joel Fajardo, Mayor

ATTEST:

Elena G. Chávez, City Clerk

APPROVED AS TO FORM:

Rick R. Olivarez, City Attorney

STATE OF CALIFORNIA)
COUNTY OF LOS ANGELES) **SS.**
CITY OF SAN FERNANDO)

I, Elena G. Chávez, City Clerk of the City of San Fernando, do hereby certify that the above and foregoing Ordinance No. 1648 was introduced at the regular meeting of the City Council held on 16th day of November 2015, and thereafter at the regular meeting of said City Council, duly held on the 7th day of December 2015, was passed and adopted by the following votes to wit:

AYES:

NOES:

ABSTAIN:

ABSENT:

Elena G. Chávez, City Clerk

*This Page
Intentionally
Left Blank*

*This Page
Intentionally
Left Blank*



AGENDA REPORT

To: Mayor Joel Fajardo and Councilmembers

From: Richard Padilla, Deputy City Attorney

Date: December 7, 2015

Subject: Ratification and Re-approval of City Clerk Employment Agreement Originally Approved on November 16, 2015 Subject to Certain Clarifying Amendments and Modifications to More Precisely Effectuate the Intent of the Parties

RECOMMENDATION:

It is recommended that the City Council:

- a. Ratify and re-approve the City Clerk Employment Agreement (Attachment "A" - Contract No. 1804) originally approved by the City Council at its meeting of November 16, 2015 subject to certain clarifying amendments and modifications set forth in the updated agreement document; and
- b. Adopt Resolution No. 7718 (Attachment "B") regarding Public Employee Retirement System, paying and reporting the value of Employer Paid Member Contributions.

BACKGROUND:

At its meeting of November 16, 2015, the City Council approved the form of a City Clerk Employment Agreement ("Agreement") with current City Clerk Elena G. Chávez. The salient provisions of the Agreement were as follows:

- Base term of five years;
- Base annual salary of \$101,053;
- Twelve months maximum severance if Chávez is terminated for convenience;
- Chávez would receive certain benefits provided to the City's executive employments pursuant to City Council Resolution No. 7692 including annual leave, management leave, bereavement leave etc., wellness reimbursement;
- As a classic CalPERS employee Chávez retains her 3% at 60 status;
- Chávez will not accrue additional annual leave during any period in which bank of annual leave exceeds 300 hours; and
- Chávez will cash out pre-existing sick leave and convert pre-existing vacation leave into annual leave.

Ratification and Re-approval of City Clerk Employment Agreement Originally Approved on November 16, 2015 Subject to Certain Clarifying Amendments and Modifications to More Precisely Effectuate the Intent of the Parties

Page 2 of 3

In the course of addressing specific issues relating to the implementation of the Agreement, it was determined that certain clarification would be necessary to ensure that the intent of the parties was properly and precisely effectuated. In an abundance of caution, the Agreement has been modified with certain clarifying edits which include the following:

1. Under Section 2.2.B, it was determined that the CalPERS contribution schedule of City Council Resolution No. 7692 ("Resolution No. 7692") applicable to City Department Heads is not intended to apply to Chávez. Resolution No. 7692 contemplates an increasing contribution percentage for First Tier members over time of 6.0% effective July 1, 2015, 7.0% effective July 1, 2016 and 7.5% effective July 1, 2017. **Instead**, Chávez will continue to receive same contribution percentage of 4% which she presently receives throughout the term of the Agreement. Resolution No. 7718 memorializing this arrangement is attached (Attachment "B").
2. Under subsection B.1 of Section 2.3 relating to the conversion of Chávez' Pre-Existing Vacation Leave time into Annual Leave time, the Agreement has been modified to specify that the conversion will be done in accordance with the formula set forth under Section 6 of Resolution No. 7692 which provides that Vacation Leave which is converted to Annual Leave will be converted at one hour of Vacation Leave to one hour of Annual Leave.
3. Under subsections B.2 and B.3 of Section relating to the contemplated cash-out of Chávez's Pre-Existing Sick Leave and Pre-Existing Comp Time, clarifying language is added to specify that Chávez will receive the full value of her Pre-Existing Sick and Comp based on her base salary prior to the Effective Date of the Agreement.
4. Under Section 2.5 relating to paid holidays, language is included to specify that Chávez will receive paid holidays on the same terms as City Department Heads under Resolution No. 7692.
5. The wording of subsection A of Section 2.14 (Other Benefits) has been modified to stress that Chávez may receive certain other non-monetary benefits customarily afforded to City Department heads, except to the extent the Agreement provides otherwise or exempts Chávez from the receipt of such other benefits.
6. Subsections B, C and D have also been added to Section 2.14 to specify that (a) Chávez will not receive a car allowance as provided under Section 9 of Resolution No. 7692; (b) salary increases described under Section 2 of Resolution No. 7692 are not applicable to Chávez; and (c) Chávez will not receive the Technology Reimbursement referenced under Section 8 of Resolution No. 7692.

Ratification and Re-approval of City Clerk Employment Agreement Originally Approved on November 16, 2015 Subject to Certain Clarifying Amendments and Modifications to More Precisely Effectuate the Intent of the Parties

Page 3 of 3

The clarifying edits referenced above: do not increase the base salary originally set forth under the November 16, 2015 draft approved by the City Council; do not increase the term of the agreement beyond what was approved on November 16, 2015; and do not alter the severance arrangement set forth under the draft originally approved on November 16, 2015. The edits clarify the conversation formula for vacation time converted to annual leave time and also clarify the payout rate for previously accrued but unused sick leave and comp time. The document also memorializes that the City's CalPERS contribution percentage will remain the same as it is now rather than increase over time and that certain benefits offered to department heads (e.g., car allowance and technology allowance) will not be provided Chávez. In all other salient and major substantive respects, the document is the same as the document approved November 16, 2015.

BUDGET IMPACT:

The total annual additional cost of the proposed contract with the City Clerk is outlined in the table below:

Fiscal Year	General Fund	Retirement Fund
2015-2016 (Net of budgeted OT)	\$10,460	\$1,765
2016-2017 Add'l Cost	\$2,980	\$350
2017-2018 Add'l Cost	\$3,038	\$365
2018-2019 Add'l Cost	\$3,110	\$370
2019-2020 Add'l Cost	\$ -	\$ -

In addition, there is a one-time payout for existing sick and compensatory time leave banks as follows:

Comp time payout (96 hours): \$4,410
 Sick time payout (353 hours): \$16,270
 Total Payout: \$20,680

CONCLUSION:

It is recommended that the City Council approve the attached updated iteration of the City Clerk Employment Agreement which includes the clarifying edits referenced above.

ATTACHMENTS:

- A. Contract No. 1804
- B. Resolution No. 7718

ATTACHMENT "A"**CONTRACT NO. 1804**

2015
CITY CLERK EMPLOYMENT AGREEMENT
(Employee: Elena Chavez)

THIS 2015 CITY CLERK EMPLOYMENT AGREEMENT ("Agreement") is made and entered into on this ____ day of December 2015 by and between the CITY OF SAN FERNANDO, a municipal corporation and general law city ("CITY") and ELENA CHAVEZ, an individual ("CHAVEZ"). For purposes of this Agreement, the capitalized term "Parties" shall be a collective reference to both CITY and CHAVEZ. The capitalized term "Party" may refer to either CITY or CHAVEZ interchangeably and reasonably appropriate.

RECITALS

THIS AGREEMENT is made and entered into in consideration of the following:

WHEREAS, the City Clerk is an appointive officer of the City of San Fernando, established pursuant to California law and appointed by the City Council; and

WHEREAS, the public office of City Clerk is established pursuant to Division 3 (City Clerk) of Article III (Officers and Employees) of Chapter 2 (Administration) of the San Fernando Municipal Code; and

WHEREAS, CHAVEZ represents that she has the requisite specialized skills, training, certifications and experience required to serve as the City Clerk for the City of San Fernando; and

WHEREAS, CHAVEZ desires to accept employment as City Clerk subject to the consideration, terms and conditions set forth under this Agreement; and

WHEREAS, the City Council initially approved this Agreement and the execution of the same in open session at its meeting of November 16, 2015; and

WHEREAS, subsequent to the November 16, 2015 the Parties sought to make certain amendments and clarifying edits to more precisely effectuate the intent of the Parties; and

WHEREAS, the Agreement was re-affirmed, ratified and approved, subject to certain clarifying amendment, by the City Council at its meeting of December 7, 2015; and

WHEREAS, the Parties desire, however, that the Agreements provisions take effect as of November 16, 2015, the date of initial approval.

NOW, THEREFORE, for and in consideration of the mutual agreements contained herein, CITY and CHAVEZ agree as follows:

SECTION 1. POSITION, TERM, DUTIES

1.1 Employment as City Clerk

This Agreement establishes the terms and conditions of employment of CHAVEZ as City Clerk for the City of San Fernando.

1.2 Duration of Employment

A. CHAVEZ's employment with CITY shall be at-will and CHAVEZ shall, at all times, serve at the pleasure of and at the convenience of the City Council of CITY. This Agreement may be terminated by either Party at any time for convenience subject to the notification and termination provisions prescribed in this Agreement.

B. The foregoing notwithstanding, nothing in this Section shall operate to prohibit, modify or otherwise restrict the City Council's ability to terminate CHAVEZ's employment at any time for cause. Nothing in this section shall prevent, limit, or otherwise interfere with the right of CHAVEZ to voluntarily terminate or resign at any time from her position with the CITY, subject to the notification and termination provisions hereunder.

C. This Agreement shall have a term of five (5) years commencing as of November 16, 2015 ("Term"). For purposes of this Agreement, November 16, 2015 may hereinafter be referred to as the "Effective Date".

1.3 Duties and Responsibilities

A. CHAVEZ shall perform the duties and functions of the City Clerk as specified under the laws of the State of California, the San Fernando Municipal Code, the ordinances and resolutions and policies of the CITY and this Agreement. CHAVEZ shall also perform such other duties and functions as the City Council may assign from time to time.

B. CHAVEZ shall serve as the City Clerk and shall be vested with the powers, duties and responsibilities of the City Clerk as set forth in Division 3 (City Clerk) of Article III (Officers and Employees) of Chapter 2 (Administration) of the San Fernando Municipal Code ("Division 3"), as the same may be repealed, amended, modified or clarified from time to time by the City Council by ordinance or resolution. CHAVEZ shall also perform those tasks and functions set forth under Exhibit A to that certain Resolution No. 7712 approved by the City Council on _____ 2015 which approves Supplement No. 172 to that certain Position Classification Plan approved on December 12, 1966 by way of City Council Resolution No. 4144. CHAVEZ's performance of her duties shall be subject to the direction and oversight of the City Council. Subject to the terms and conditions of all applicable collective bargaining agreements with the City and all City employment policies and procedures, the City Council by resolution reserves the right to authorize the assignment of permanent and/or temporary staff to Department of the City Clerk and CHAVEZ will be responsible for the day-to-day supervision of such staff.

1.4 Hours of Work

A. The position of City Clerk shall be deemed an exempt position under state and federal wage and hour laws. CHAVEZ's compensation (whether salary or benefits or other allowances) is not based on hours worked and CHAVEZ shall not be entitled to any compensation for overtime.

B. CHAVEZ shall be allowed reasonable flexibility in setting her own office hours, provided: (i) CHAVEZ maintains a reasonably substantial onsite presence at City Hall during

normal CITY business hours which, as of the Effective Date of this Agreement are Monday through Thursday 7:30 am to 5:30 pm and alternating Fridays from 8:00 am to 5:00 pm; and (ii) CHAVEZ is reasonably available to members of the City Council, members of CITY commissions, CITY staff and members of the public transacting business with the Department of the City Clerk on a regular and routine basis that generally conforms to the CITY's normal business hours as the same may be amended from time to time by the City Council.

C. Consistent with subsection B, above, CHAVEZ's work hours may generally conform to the 9/80 work schedule afforded department heads and directors, however, CHAVEZ understands that the duties, demands and responsibilities of the office of City Clerk may from time to time require that she work days and hours that do not strictly conform to the 9/80 schedule generally afforded to other department head level staff and shall be available to discharge the duties and responsibilities of City Clerk at all times as reasonably necessary.

1.5 Regional and Professional Activities

The City Council desires that CHAVEZ be reasonably active in professional organizations that will promote the standing of the CITY and advance the CITY's goals, interests and policy objectives while also providing CHAVEZ with opportunities for the type of professional development that will enhance her ability to serve the CITY and perform her duties as City Clerk. Toward this end, CHAVEZ may, upon reasonable notice and approval by the City Council, join professional organizations and participate in the activities of such organizations insofar as such participation promotes the interests of the CITY and does not unduly interfere with the performance of CHAVEZ's duties as City Clerk. Subject to funding availability as determined by the City Council in its sole and absolute discretion, CITY may pay for the dues and subscriptions of the City Clerk necessary for her participation in national, statewide, regional or professional organizations.

1.6 [Reserved – No Text]

1.7 Conflicts of Interest

CHAVEZ shall not, during the term of this Agreement, individually, as a partner, joint venture, officer or shareholder, invest or participate in any business venture conducting business in the corporate limits of the CITY, except for stock ownership in any company whose capital stock is publicly held and regularly traded, without prior approval of the City Council. CHAVEZ shall further refrain from developing a financial stake in any commercial venture or partnership with any entity doing business with the CITY where such financial stake would create a violation of Government Code Section 1090. For and during the term of this Agreement and any extension term, CHAVEZ further agrees that except for a personal residence or residential property acquired or held for future use as her personal residence, CHAVEZ will not invest in any other real estate or property improvements within the corporate limits of the CITY without the prior consent of the City Council and subject to the restrictions of all applicable financial conflict of interest laws.

1.8 ICMA Code of Ethics

A. CHAVEZ shall comply with the latest published edition of the written Code of Ethics of the International City/County Management Association ("ICMA"), provided such compliance is not inconsistent with or contrary to the laws of the State of California or the San Fernando Municipal Code.

B. CITY and the City Council agree that neither the City Council nor any of its members will give CHAVEZ any order, direction, or request that would require CHAVEZ to violate the ICMA Code of Ethics, unless such direction or request is authorized by the laws of the State of California or the San Fernando Municipal Code.

1.9 Performance Evaluation

A. Annual performance evaluations are an important way for the City Council and CHAVEZ to ensure effective communications about expectations and performance. The City Council reserves the right, but assumes no obligation, to conduct a job performance evaluation and review of CHAVEZ once each calendar year with the first such evaluation and review occurring no earlier than the first anniversary of the Effective Date.

B. In conducting the review the Parties may, but shall not be required to, use the services of a professional consultant selected by the City Council. The job performance evaluation and review shall serve the following purposes and objectives: (i) to evaluate CHAVEZ's overall job performance over the course of the fiscal year; (ii) to identify areas of notable progress and/or accomplishment and identify ways to sustain and/or improve upon such progress and/or accomplishments; (iii) to identify areas requiring improvement and how such improvement might be accomplished; (iv) to measure CHAVEZ's success in meeting, achieving and/or exceeding City Council-defined goals, objectives, priorities, activities and programs over the fiscal year or since the last performance evaluation and review; (v) to establish goals, objectives, and priorities for the upcoming year; (vi) to determine what, if any, adjustments or enhancement should be considered and approved to CHAVEZ's compensation terms.

C. The failure of CITY to undertake a performance evaluation shall not limit CITY's ability to terminate this Agreement pursuant to Section 3, below. Nothing in this Section 1 shall be construed to restrict or otherwise limit the ability of the CITY to undertake any other review or investigation of CHAVEZ during the course of a fiscal year which the City Council may deem necessary to address any allegation of unlawful or inappropriate conduct or other wrongdoing.

SECTION 2. BASE COMPENSATION; BENEFITS AND REIMBURSEMENTS

2.1 Salary and Other Monetary Compensation

A. Base Salary. CITY shall pay CHAVEZ an annual base salary of One Hundred and One Thousand, Fifty-Three Dollars (\$101,053) per year (hereinafter, the "Base Salary"), subject to deductions for taxes, deferred compensation and other out-of-pocket benefits paid for by CHAVEZ as a CITY department head employee. CITY shall pay CHAVEZ in bi-weekly installments at the same time other employees of CITY are paid. Commencing July 1, 2016 and each July 1st thereafter up to July 1, 2018, the Base Salary shall increase by an amount equal to two percent (2%) of the most recent Base Salary amount.

B. Bilingual Bonus and Longevity Pay. CHAVEZ shall receive a bilingual bonus and longevity pay subject to the same terms and conditions the same are provided to City department heads under City Council Resolution No. 7692 approved August 3, 2015 (hereinafter, "Resolution No. 7692") as the same may be later repealed, amended or modified.

2.2 Retirement/Deferred Compensation

A. CHAVEZ shall receive any and all employee retirement and deferred compensation benefits otherwise accorded CITY's department head employees, consistent with CITY policies, including the CITY policy through the Public Employees Retirement System ("PERS") and applicable law. The PERS formula to be applied to CHAVEZ will be 3% at 60, single highest year compensation retirement calculation which applies to First Tier "Classic" members as referenced under Section 5 (Retirement) of Resolution No. 7692. CHAVEZ shall also be eligible for deferred compensation through voluntary contribution to the 457 Deferred Compensation plan available through the ICMA.

B. Notwithstanding anything set forth under Resolution No. 7692 to the contrary and consistent with City Council Resolution No. 7718 dated December 7, 2015, the City shall continue to pay 4.0% of for CHAVEZ's First Tier CalPERS membership throughout the Term of this Agreement. The City's payments shall be treated as a "pick up" of employee contributions pursuant to IRC 414(h)(2). The City shall continue to report the value of the Employer Paid Member Contribution to CalPERS as compensation earnable on behalf of CHAVEZ, pursuant to Government Code Section 20636(c)(4).

2.3 Annual Leave (Vacation and Sick)

A. Accrual of Annual Leave.

1. For purposes of this Agreement the term "Annual Leave" shall have the same meaning as set forth under Resolution No. 7692 or as the meaning of the term "Annual Leave" may be modified or amended by subsequent resolutions of the City Council that repeal, amend or otherwise modify the term "Annual Leave" as defined under Resolution No. 7692. Except as otherwise provided under this Agreement, commencing upon the Effective Date and throughout the term of this Agreement, CHAVEZ shall accrue Annual Leave in the same amount and in the same manner accrued by the City's Department Head Classification employees as set forth under Resolution No. 7692 or as the package of compensation and other benefits set forth under Resolution No. 7692 may be subsequently repealed, amended or otherwise modified by subsequent City Council resolution. The Parties acknowledge and agree that commencing upon the Effective Date, the above-described Annual Leave shall be given to CHAVEZ in lieu, and not in addition to, vacation leave and sick leave previously allocated to CHAVEZ prior to the Effective Date. Upon the Effective Date CHAVEZ shall cease to accrue vacation leave and sick leave.

2. Subsection 2.3.A.1 of this Agreement notwithstanding, CHAVEZ will not accrue any additional Annual Leave time during any period of time in which CHAVEZ's total bank of accrued but unused Annual Leave equals or exceeds a total of three hundred (300) hours. At such time as CHAVEZ's total bank of accrued but unused Annual Leave falls below 300 hours total, CHAVEZ will resume the accrual of Annual Leave until such newly accrued hours cause CHAVEZ's total bank of accrued but unused Annual Leave to again equal 300 hours.

B. Pre-existing Leave Hours.

1. As of the Effective Date of this Agreement, the Parties acknowledge and agree that CHAVEZ's pre-existing bank of accrued but unused vacation leave hours total 281.80 hours (hereinafter, the "Pre-Existing Vacation Leave Hours"). Upon the Effective Date, CHAVEZ's Pre-Existing Vacation Leave Hours shall be converted to Annual Leave Hours. The conversion

of CHAVEZ's Pre-Existing Vacation Leave Hours to Annual Leave shall count toward the 300 hour cap referenced under subsection 2.3.A.2, above. The conversion of Pre-Existing Vacation Leave Hours to Annual Leave shall be in accordance with Resolution No. 7692 as the same may be subsequently, repealed, amended or otherwise modified.

2. As of the Effective Date of this Agreement, the Parties acknowledge and agree that CHAVEZ's pre-existing bank of accrued but unused sick leave hours total 356.67 hours (hereinafter, "Pre-Existing Sick Leave Hours"). Within thirty (30) calendar days from the Effective Date, CHAVEZ shall sell back and CITY shall purchase, the full value of CHAVEZ's Pre-Existing Sick Leave Hours at a rate reflective of CHAVEZ's base salary prior to the Effective Date of this Agreement.

3. As of the Effective Date of this Agreement, the Parties acknowledge and agree that CHAVEZ's pre-existing bank of accrued but unused comp time hours total 95.68 hours (hereinafter, the "Pre-Existing Comp Time Amount"). Within thirty (30) calendar days from the Effective Date, CHAVEZ shall sell back and CITY shall purchase, the full value of CHAVEZ's Pre-Existing Comp Time Hours at a rate reflective of CHAVEZ's base salary prior to the Effective Date of this Agreement.

4. The Parties acknowledge and agree that upon the Effective Date, CHAVEZ shall cease to accrue additional vacation leave or additional sick leave but shall instead receive Annual Leave as described under subsection A of this Section above. The Parties further acknowledge and agree that upon the Effective Date, CHAVEZ shall cease to accrue any other variety of leave not otherwise expressly provided for under this Agreement.

5. CHAVEZ shall provide both the Mayor and the Vice Mayor with no less than fourteen (14) calendar days prior written notice in the event CHAVEZ intends to take any pre-scheduled time off (e.g., vacation and/or conferences etc.) anticipated to last more than two (2) consecutive CITY work days. A courtesy notice shall also be provided to the City Manager. CHAVEZ shall also use all reasonable efforts to coordinate the scheduling of vacation time off or other pre-scheduled time off with other City Clerk Department staff so as to ensure that routine City Clerk Department operations and duties, including the timely preparation and publication of City Council agendas is not unreasonably disrupted. CHAVEZ shall refrain from taking vacation time off during the thirty-day period immediately preceding and the thirty-day period immediately following any regularly scheduled general municipal election of the City of San Fernando. In so far as the City Council calls a special municipal election, CHAVEZ shall refrain from scheduling any vacation time off during the thirty-day period immediately preceding and the thirty-day period immediately following any such special municipal election but may take vacation time off in so far as such time was scheduled and formally requested by CHAVEZ prior to the calling of the special municipal election.

2.4 Additional Miscellaneous Benefits.

A. Commencing upon the Effective Date, CHAVEZ shall receive the following benefits in the manner prescribed under Resolution No. 7692 as the same may be repealed, amended or otherwise modified in whole or in part by subsequent City Council resolution: (i) Management Leave; (ii) Bereavement Leave; and (iii) Wellness Reimbursement Benefit

2.5 Holidays

CHAVEZ shall receive paid holidays in accordance with CITY's current practices as set forth under Section 6 of Resolution No. 7692 as such practices may be amended or modified from time to time by the CITY by action of the City Council. Paid holidays will be those approved by the CITY by action of the City Council. The CITY currently provides twelve (12) paid holidays per calendar year.

2.6 Medical, Dental and Vision Insurance

Except as otherwise set forth in this Agreement, and in addition to the benefits specified herein, CHAVEZ shall receive the same employee medical, dental, and vision insurance benefits provided under Section 4 of Exhibit "A" of Resolution No. 7692 as the same may be repealed, amended or otherwise modified by subsequent City Council resolution.

2.7 Bonding

Except as otherwise provided under the City Municipal Code or applicable state law, CITY shall bear the full cost of any fidelity or other bonds required of CHAVEZ under any law or ordinance.

2.8 Cellular Phone Allowance; Other Necessary and Customary Business Equipment and Facilities; Special Electronic Equipment

A. CITY recognizes that CHAVEZ's duties as City Clerk may require extensive use of a cell phone in the ordinary course of performing her duties as City Clerk. Accordingly, CITY shall provide CHAVEZ with a cell phone allowance in the amount of Sixty Dollars (\$60.00) per month for the use of CHAVEZ's personal cell phone to conduct CITY business. CITY shall not be responsible for any cellular phone related expenses in excess of the allowance set forth herein nor shall CHAVEZ be entitled to reimbursement for such expenses pursuant to Section 2.9.

B. The CITY shall provide CHAVEZ with other customary and necessary equipment and facilities reasonably required for CHAVEZ to perform her duties and functions as City Clerk such as an office within City Hall, a landline telephone in the City Hall office, a desktop computer, a new laptop computer, business cards, business stationary and the like. All such equipment and facilities made available to CHAVEZ shall at all times remain the property of the CITY and CHAVEZ acknowledges, understands and agrees that she shall have no right of privacy to such equipment or any data or information stored in such equipment or facilities.

C. The City Council reserves the right but does not assume the obligation to provide CHAVEZ at CITY's expense, special electronic communications equipment such as an iPad. All such equipment and facilities made available to CHAVEZ shall at all times remain the property of the CITY, and CHAVEZ acknowledges, understands and agrees that she shall have no right of privacy to such equipment or any data or information stored in such equipment or facilities.

2.9 Reimbursement for Expenses Not Covered by Allowances

Excluding those expenses already covered by the supplemental compensation allowances set forth under Sections 2.7 and 2.8 above, CITY shall reimburse CHAVEZ for

reasonable and necessary travel, subsistence and other business expenses incurred by CHAVEZ in the performance of her duties or in connection with CHAVEZ's participation in those authorized activities referenced under Section 1.3, above. All reimbursements shall be subject to and in accordance with any limitations or restrictions set forth under the laws of the State of California and any CITY-adopted reimbursement policies as either may be adopted, updated or otherwise amended from time to time by the San Fernando City Council.

2.10 [RESERVED – NO TEXT]

2.11 Term Life Insurance

Except as otherwise set forth in this Agreement, and in addition to the benefits specified herein, CHAVEZ shall receive any and all term life insurance program benefits otherwise accorded CITY's department head employees, as prescribed as of the Effective Date of this Agreement and as those benefits may be changed from time to time.

2.12 Jury Duty

CHAVEZ will receive full pay and benefits while responding to a jury summons or serving on a jury, up to a maximum of fourteen (14) business days. Any compensation for such jury duty (except travel pay) shall be remitted to CITY.

2.13 Professional Development Conference

CHAVEZ shall be permitted to attend the annual professional development conference for city clerks organized by the California League of Cities and may receive reimbursement for travel, transportation and lodging at such conference in accordance with the City's travel and reimbursement policy as the same may be updated, amended and/or modified from time to time by the City Council.

2.14 Other Benefits

A. Except as otherwise provided or excepted under this Agreement, CHAVEZ shall receive any and all other non-monetary benefits as are customarily provided to all of the CITY's department head employees pursuant to applicable State law, applicable provisions of the San Fernando Municipal Code and other applicable policies, rules and regulations adopted by City Council resolution as policies, rules and regulations may be amended, repealed or otherwise modified from time to time.

B. Subsection A of this Section notwithstanding, CHAVEZ shall not receive a car allowance benefit, including the car allowance benefit referenced under Section 9 (Car Allowance) of Resolution No. 7692.

C. Subsection A of this Section notwithstanding, the 2% Base Salary increases scheduled for July 1, 2016, July 1, 2017 and July 1, 2018 as referenced under Section 2.1 of this Agreement are in lieu of and in place of the schedule of salary increases referenced under Section 2 (Salary) of Resolution No. 7692 and shall not be in addition to such increases.

D. Subsection A of this Section notwithstanding, CHAVEZ shall not receive the Technology Reimbursement referenced under Section 8 of Resolution No. 7692.

SECTION 3. EMPLOYMENT “AT-WILL”; SEPARATION FROM EMPLOYMENT

3.1 Employment with CITY is “at-will”

A. CHAVEZ’s employment status with CITY shall be “at-will” and CHAVEZ shall serve at the pleasure of the City Council as provided under Government Code Section 36506. CITY, through the City Council, may at any time terminate CHAVEZ’s employment with the CITY with or without cause by majority vote of its full membership (i.e., by no less than three affirmative votes). CHAVEZ acknowledges, understands and agrees that CHAVEZ may not avail herself of any procedures, provisions or protections set forth under the CITY’s Employment Policies, as defined herein, insofar as such procedures, provisions or protections limit, restrict, modify, prohibit or regulate CHAVEZ’s status as an “at-will” employee of CITY or the ability of the City Council to terminate CHAVEZ’s employment at any time for cause or for convenience. For purposes of this Agreement, the capitalized term “Employment Policies” means and refers to any ordinance, resolution, regulation, rule or other written policy of the CITY as the same may be amended, modified or supplemented from time to time (including but not limited to the San Fernando Municipal Code and any written employment manual of the CITY) which governs, regulates or otherwise relates to employment with the CITY. The CITY’s Employment Policies shall not apply to CHAVEZ insofar as such Employment Policies limit, restrict, modify or regulate (or may be interpreted to limit, restrict, modify or regulate) CHAVEZ’s status as an “at-will” employee of CITY.

B. Except as otherwise provided under this Section 3, CHAVEZ shall not be entitled to any pre-termination hearing or other similar proceeding or appeal proceeding as a precondition to any decision or action by the City Council to terminate CHAVEZ’s employment whether for cause or for convenience.

C. Nothing in this Agreement shall confer upon CHAVEZ any right to any property interest in continued employment with the CITY.

3.2 Resignation/Retirement

A. CHAVEZ may resign and/or retire from her employment with the CITY at any time for any reason, provided CHAVEZ provides the City Council with written notice of her intent to so terminate her employment at least forty-five (45) calendar days prior to the effective date of separation.

B. The City Council in its sole and absolute discretion may waive or shorten the 45-day prior written notice requirement provided the request for such waiver is made in writing by CHAVEZ and further provided that the City Council’s waiver of the notice requirement is also made in writing.

C. The failure of CHAVEZ to provide the prior written notice required under this Section shall constitute a material breach of this Agreement.

3.3 Separation for Convenience and Without Cause; Severance

A. In the event CHAVEZ is terminated for convenience and without cause by the City Council while CHAVEZ is willing and able to perform the City Clerk’s duties under this Agreement, then in that event the CITY agrees to pay CHAVEZ a lump sum cash payment equal to twelve (12) months worth of CHAVEZ’s annual Base Salary at the time of separation

[i.e., the prorated value of one months' worth of CHAVEZ's annual Base Salary at the time of separation multiplied by twelve months].

B. CITY shall extend to CHAVEZ the right to continued health insurance as may be required by and pursuant to terms and conditions of this Consolidated Omnibus Reconciliation Act of 1986 ("COBRA"). The CITY agrees to pay CHAVEZ's COBRA coverage for the same number of months for which CHAVEZ is entitled to a lump sum cash payment under Section 3.3(A), or until CHAVEZ either secures and begins full-time employment or obtains other health insurance, whichever of these three events first occurs. CHAVEZ shall notify the CITY within five (5) calendar days of securing new full-time employment or insurance.

C. All payments required under Section 3.3(A) or 3.3(B), above, are subject to and shall be interpreted to comply with the limitations set forth in Government Code Section 53260. Further, in the event CHAVEZ is convicted of a crime involving an abuse of office or position, CHAVEZ shall reimburse the CITY for any paid leave or cash settlement (including severance), as provided by Government Code Sections 53243 through 53243.4.

D. The foregoing notwithstanding, CITY shall not exercise its right to terminate CHAVEZ for convenience and without cause during the 120-day period immediately preceding or the 120-day period immediately following any General Municipal Election of the CITY in which two or more City Council seats are subject to an election contest or during the 120-day period immediately preceding or the 120-day period immediately following any Special Municipal Election of the CITY in which two or more City Council seats are subject to an election contest.

3.4 Separation for Cause

A. Notwithstanding the provisions of Section 3.3, above, CHAVEZ may be terminated for cause. As used in this Section, "cause" shall mean any one or more of the following:

- (i) Any Breach of this Agreement;
- (ii) Conviction (including a plea of no contest) of a felony or any misdemeanor under the Political Reform Act (Government Code Section 81000 et seq.) or Government Code Section 1090;
- (iii) Conviction (including a plea of no contest) of any offense constituting an "abuse of office or position" within the meaning of Government Code Section 53243.4;
- (iv) Conviction (including a plea of no contest) of a misdemeanor involving a crime of moral turpitude or felony under California law, including but not limited to any conviction under Penal Code Section 424;
- (v) Intoxication on duty, whether by alcohol, non-prescription drugs or any controlled substance.
- (vi) Repeated and protracted unexcused absences from CHAVEZ's office and duties;
- (vii) Fraud or dishonesty in securing her employment, including resume fraud;

- (viii) A finding by judicial proceeding that legally prohibited personal acts of sexual harassment against a CITY official or employee or legally prohibited acts of discrimination against a CITY official or employee have occurred;
- (ix) A pattern of repeated, willful and intentional failure to carry out materially significant and legally constituted policy decisions of the City Council made by the City Council as a body, or persistent willful violation of properly established rules and procedures; and
- (x) Any other action or inaction of CHAVEZ that materially and substantially impedes or disrupts the performance of CITY or its organizational units or is detrimental to employee safety or public safety.

The City Council, in its sole and absolute discretion, may place CHAVEZ on administrative leave with pay until resolution of allegations or charges, including but not limited to criminal charges, brought against CHAVEZ, or until a final judicial or administrative decision finding legally prohibited personal acts of sexual harassment against a CITY official or employee or legally prohibited personal acts of discrimination against a CITY official or employee. Prior to terminating this Agreement pursuant to this Section, the City Council shall give CHAVEZ at least ten (10) calendar days prior written notice of the charges. Within the ten-day period, but not earlier than five (5) calendar days after the notice has been given, the City Council shall meet with CHAVEZ in closed session and give CHAVEZ an opportunity to address the City Council regarding the charges. CHAVEZ may have a representative at the closed session with the City Council. After hearing CHAVEZ's response to the charges, the City Council shall make a decision as to whether to terminate this Agreement and shall inform CHAVEZ in writing of its decision. Other than as provided in this subsection, CHAVEZ expressly waives any other form of hearing or appeal of the City Council's decision. Nothing in this subsection creates a property right in employment. Notwithstanding anything contained in this subsection, CHAVEZ remains an at will employee serving at the pleasure of the City Council. The initiation of termination proceedings for cause shall not operate to prohibit or otherwise restrict the City Council from exercising its right to terminate CHAVEZ without cause as provided under Section 3.3 of this Agreement.

B. In the event the CITY terminates CHAVEZ for cause, then the CITY may terminate this Agreement immediately, and CHAVEZ shall be entitled to only the compensation accrued up to the date of termination, payments required under Sections 2 and subsection 3.3 and such other termination benefits and payments as may be required by law. In the event of termination for cause, the City Clerk shall not be entitled to any severance provided for under subsection 3.3, above. The foregoing notwithstanding, CITY may deduct from such payments any reimbursement sums it is owed pursuant to Government Code Sections 53243 through 53243.4.

3.5 Return of City Equipment

CHAVEZ agrees that all property, including without limitation, all equipment, tangible, Proprietary Information (as defined below), documents, records, notes, contracts, and computer-generated materials furnished to or prepared by her incident to her employment are the property of CITY and shall be returned promptly to CITY upon termination of CHAVEZ's employment. CHAVEZ's obligations under this subsection shall survive the termination of her employment and the expiration or early termination of this Agreement.

SECTION 4. GENERAL PROVISIONS

4.1 Proprietary Information

“Proprietary Information” means all information and any idea pertaining in any manner to the business of the City Council, the CITY or the CITY’s various departments, divisions, committees and commissions, which was produced by CHAVEZ in the course of her employment or otherwise produced to or acquired by CHAVEZ in the course of her employment with the CITY. Proprietary Information shall include, without limitation, trade secrets, product ideas, inventions, processes, formulae, data, know-how, software and other computer programs, copyrightable material, marketing plans, strategies, sales, financial reports, forecasts and customer lists. All Proprietary Information not generally known outside of CITY’s organization, and all Proprietary Information so known only through improper means, shall be deemed “Confidential Information”. During her employment by CITY, CHAVEZ shall use Proprietary Information, and shall disclose Confidential Information, only for the benefit of CITY and as is or may be necessary to perform her job responsibilities under this Agreement. Following termination, CHAVEZ shall not use any Proprietary Information and shall not disclose any Confidential Information, except with the express written consent of CITY. CHAVEZ’s obligations under this Section shall survive the termination of her employment and the expiration of this Agreement.

4.2 Notices

All notices, requests, demands and other communications under this Agreement shall be in writing and shall be effective upon delivery by hand or three (3) business days after deposit in the United States mail, postage prepaid, certified or registered, and addressed to CITY at the address below, and or at the last known address maintained in CHAVEZ’s personnel file. CHAVEZ agrees to notify CITY in writing of any change in her address during her employment with CITY. Notice of change of address shall be effective only when accomplished in accordance with this Section.

CITY’s Notice Address:

City of San Fernando
117 Macneil Street
San Fernando, California 91340
Attn: Mayor and City Council

City Clerk’s Address: [Deliver to last updated address in personnel file]

4.3 Indemnification

A. CITY shall defend, hold harmless and indemnify CHAVEZ against any claim, demand, judgment or action of any type or kind arising within the course and scope of CHAVEZ’s employment to the extent required by Government Code Sections 825 and 995.

B. Subsection (A) of this Section notwithstanding, CITY reserves all rights (including all rights to monetary reimbursement) afforded under Government Code Sections 53243, 53243.1, 53243.2, 53243.3 and 53243.4 and nothing in this Agreement shall be operate or otherwise be construed to place any restriction upon CITY in exercising and/or enforcing such

rights under the foregoing Government Code Sections. In the event CHAVEZ is convicted of an offense constituting an abuse of office or position, CHAVEZ shall reimburse CITY for any sums expended investigating and/or defending such wrongdoing as provided under Government Code Section 53243, 53243.1 and 53243.3. For purposes of this Agreement, the phrase "abuse of office or position" shall have the same meaning as set forth under Government Code Section 53243.4

4.4 Entire Agreement

This Agreement is intended to be the final, complete, and exclusive statement of the terms of CHAVEZ's employment by CITY. This Agreement supersedes all other prior and contemporaneous agreements and statements, whether written or oral, express or implied, pertaining in any manner to the employment of CHAVEZ, and it may not be contradicted by evidence of any prior or contemporaneous statements or agreements. To the extent that the practices, policies, or procedures of CITY, now or in the future, apply to CHAVEZ and are inconsistent with the terms of this Agreement, the provisions of this Agreement shall control.

4.5 Amendments

This Agreement may not be altered, modified, or amended except in a written document signed by CHAVEZ, approved by the City Council and signed by Mayor.

4.6 Waiver

Failure to exercise any right under this Agreement shall not constitute a waiver of such right.

4.7 Assignment

CHAVEZ shall not assign any rights or obligations under this Agreement. CITY may, upon prior written notice to CHAVEZ, assign its rights and obligations hereunder.

4.8 Severability

If any court of competent jurisdiction holds any provision of this Agreement to be invalid, unenforceable, or void, the remainder of this Agreement shall remain in full force and effect.

4.9 Attorney's Fees

In any legal action, arbitration, or other proceeding brought to enforce or interpret the terms of this Agreement, the prevailing party shall be entitled to recover reasonable attorneys' fees and costs.

4.10 Governing Law

This Agreement shall be governed by and construed in accordance with the laws of the State of California, with venue property only in Los Angeles County, State of California.

4.11 Interpretation

This Agreement shall be construed as a whole, according to its fair meaning, and not in favor of or against any party. By way of example and not in limitation, this Agreement shall not be construed in favor of the party receiving a benefit nor against the party responsible for any particular language in this Agreement. Captions are used for reference purposes only and should be ignored in the interpretation of the Agreement. Each party waives their future right to claim, contest, or assert that this Agreement was modified, cancelled superseded or changed by any oral agreement, course of conduct, waiver or estoppel.

4.12 Acknowledgment

CHAVEZ acknowledges that she has had the opportunity to consult legal counsel in regard to this Agreement, that she has read and understands this Agreement, that she is fully aware of its legal effect, and that she has entered into it freely and voluntarily and based on her own judgment and not on any representations or promises other than those contained in this Agreement.

4.13 Counterparts

The Parties agree that this Agreement may be executed in multiple originals including multiple counterparts, and that each of the counterparts to any original taken together shall constitute one valid and binding agreement between the Parties.

[SIGNATURES ON FOLLOWING PAGE]

IN WITNESS WHEREOF, CITY has caused this Agreement to be signed and executed on its behalf by its Mayor and duly attested to by its City Clerk, and CHAVEZ has signed and executed this Agreement, as of the date first indicated above.

CITY OF SAN FERNANDO

ELENA CHAVEZ

By: _____

By: _____
Elena Chavez

Print: _____

Date: _____

Date: _____

APPROVED AS TO FORM:

By: _____

Name: _____

Title: _____

DRAFT

ATTACHMENT "B"**RESOLUTION NO. 7718****A RESOLUTION OF THE CITY COUNCIL OF THE CITY OF SAN FERNANDO, CALIFORNIA, FOR PAYING AND REPORTING THE VALUE OF EMPLOYER PAID MEMBER CONTRIBUTIONS**

WHEREAS, the governing body of the City of San Fernando has the authority to implement Government Code Section 20636 (c) (4) pursuant to Section 20691;

WHEREAS, the governing body of the City of San Fernando has a written labor policy or agreement which specifically provides for the normal member contributions to be paid by the employer, and reported as additional compensation;

WHEREAS, one of the steps in the procedures to implement Section 20691 is the adoption by the governing body of the City of San Fernando of a Resolution to commence paying and reporting the value of said Employer Paid Member Contributions (EPMC);

WHEREAS, the governing body of the City of San Fernando has identified the following conditions for the purpose of its election to pay EPMC;

- This benefit shall apply to the City Clerk who is under the 3% @ 60 retirement formula.
- This benefit shall consist of paying 4% of normal member contributions as EPMC, and reporting the same percent (value) of compensation earnable {excluding Government Code Section 20636(c)(4)} as additional compensation.
- This benefit shall be paid throughout the term of City Clerk Employment Agreement No. 1804 (November 16, 2015 to November 16, 2020).

NOW, THEREFORE, THE CITY COUNCIL OF THE CITY OF SAN FERNANDO DOES HEREBY RESOLVE, FIND, DETERMINE AND ORDER that the governing body of the City of San Fernando elects to pay EPMC, as set forth above.

PASSED, APPROVED, AND ADOPTED this 7th day of December, 2015.

Joel Fajardo, Mayor

ATTEST:

Elena G. Chávez, City Clerk

STATE OF CALIFORNIA)
COUNTY OF LOS ANGELES) ss
CITY OF SAN FERNANDO)

I HEREBY CERTIFY that the foregoing Resolution was approved and adopted at a regular meeting of the City Council held on the 7th day of December, 2015, by the following vote to wit:

AYES:

NOES:

ABSENT:

Elena G. Chávez, City Clerk

*This Page
Intentionally
Left Blank*



AGENDA REPORT

To: Mayor Joel Fajardo and Councilmembers

From: Brian Saeki, City Manager
By: Chris Marcarello, Deputy City Manager/Public Works Director

Date: December 7, 2015

Subject: Preparedness Activities for Predicted El Niño Winter Storm Events

RECOMMENDATION:

It is recommended that the City Council receive and file this report.

BACKGROUND:

The National Weather Service has indicated the strong likelihood of an “El Niño” winter storm event during the coming winter months. Staff members from the City’s Police Department, Public Works Department, and Recreation and Community Services Department continue to meet regularly to discuss emergency preparedness issues and their potential impacts on our community. The City continues to take steps in order to ensure that the community is adequately prepared for potential winter storm events.

ANALYSIS:

With the predicted winter “El Niño” storm events approaching, it is prudent for the City to review its plans for potential storm events. The following summarizes recent activities related to preparedness efforts:

- City staff has ordered approximately 2,500 sandbags that will be made available to the public at no charge during rain events. In addition, the Los Angeles Fire Department has indicated that it will also make sandbags available to residents at no cost;
- In November 2015, El Niño preparedness was discussed with the City’s Disaster Council and direction was provided as to potential local problem areas in the community;
- City staff will order additional rain gear and related supplies for staff members;

Preparedness Activities for Predicted El Niño Winter Storm EventsPage 2 of 2

- Staff members from the City, Los Angeles Fire Department and County of Los Angeles has and will continue to discuss potential weather storm conditions and possible emergency situations that may result from storms;
- City staff will continue to participate in Countywide planning meetings, Area C emergency preparedness meetings, and training exercises related to anticipated storm events;
- City staff will continue to hold monthly planning meetings to evaluate storm projections, review disaster planning strategies, and assess resources needed for possible storm events;
- City staff has identified a list of potential equipment and materials needs and local rental companies that may help to improve response to possible storm situations;
- The City developed a notice for public distribution regarding storm preparedness (Attachment "A"). Information will also be disseminated via the City's website, the City newsletter, and in local publications.

CONCLUSION:

That the City Council receive and file this update.

ATTACHMENT:

A. San Fernando El Niño Brochure

EMERGENCY CHECKLIST

EMERGENCY KIT:	
Water for 3 Days	
Non-Perishable Food for 3 Days	
Pet Food and Water	
First Aid Kit and Instructions	
Flashlights and Extra Batteries	
Radio and Extra Batteries	
Medications (Prescription and Non-Prescription):	
Medication Name	
Medication Name	
Medication Name	
Cash (small bills)	
Birth Certificates	
Tax Returns	
Deeds	
Titles	
Insurance Papers	
Medical Cards	
Other Important Document	
Other Important Document	
Clothing	
Sturdy Shoes	
Adjustable Wrench	
Other Tool	
Other Tool	
Duct Tape	
Sturdy Gloves	
Fire Extinguisher	
Whistle	
Sanitation and Hygiene Supplies	
Other Item	
Other Item	
EMERGENCY KIT/SUPPLIES STORAGE LOCATION:	
MEETING PLACE:	
OUT OF STATE OR COUNTY CONTACT AND PHONE #:	

You can help yourself by being PREPARED!

Remember, during a disaster both law enforcement and fire services will be severely taxed because of the overwhelming demand for services.

Urges You To

Get Prepared!



When strong El Niño conditions exist, there is a higher probability of increased rainfall along the coast of California. The increased rainfall can result in heavier than normal runoff, causing regional and large-scale flooding.

However, it is difficult to predict how strong this winter's El Niño could become, and the effects storms may have on the West Coast. So it is important to be aware of the possible impacts from an El Niño winter and plan accordingly.

What can YOU do to get prepared?

HAVE A FAMILY EMERGENCY PLAN:

- ✓ Identify a meeting place in the event you are separated during a disaster.
- ✓ Identify a contact from out of state or out of the county.
- ✓ Know your evacuation routes and practice with your family.
- ✓ Know how to turn off your utilities and have the tools available to do so.
- ✓ Know the emergency procedures of the schools that your children attend.
- ✓ Identify safe locations in your home that can provide you with cover.
- ✓ Make special provisions for your pets, elderly family members, and those with special needs.
- ✓ Prepare an emergency kit that can provide for you and your family for at least 3 days.

YOUR EMERGENCY KIT SHOULD INCLUDE:

- ✓ Water and non-perishable food for 3 days.
- ✓ First Aid kit and instructions.
- ✓ Flashlights and extra batteries.
- ✓ Radio and extra batteries.
- ✓ Medications (prescription and non-prescription).
- ✓ Cash (small bills).
- ✓ Important documents (birth certificates, tax returns, deeds, titles, insurance papers, medical cards).
- ✓ Clothing and sturdy shoes.
- ✓ Tools (adjustable wrench, duct tape, sturdy gloves, fire extinguisher, whistle).
- ✓ Sanitation and hygiene supplies.

ADDITIONAL RESOURCES:

Disaster Management Area C
www.dmac.ca.gov

Mass Notification System
www.lacounty.gov/emergency/alert-la

Red Cross
www.RedCross.org

Comprehensive Disaster Preparedness and Recovery Guide
www.TheRedGuideToRecovery.com

County of Los Angeles Department of Emergency Management
www.emergency.lacity.org

National Weather Service
www.wrh.noaa.gov/lox

The San Fernando Police Department (Non-Emergency)
818.898.1267

San Fernando Public Works Department (Obtain Sandbags and Report Tree Safety)
818.898.1293

Get Involved!

You or your family members may volunteer to help during disasters. Check out the Community Emergency Response Team (CERT) training that is provided by the Los Angeles City Fire Department. **Visit WWW.CERT-LA.COM**

OR

Check out our disaster communications group here in San Fernando. Learn more about being a disaster communications volunteer. **Email RPOWELL@SFCITY.ORG**

*This Page
Intentionally
Left Blank*



AGENDA REPORT

To: Mayor Joel Fajardo and Councilmembers

From: Brian Saeki, City Manager
By: Chris Marcarello, Deputy City Manager/Public Works Director

Date: December 7, 2015

Subject: Consideration to Replace Heating, Ventilation and Cooling System (HVAC) Equipment at City Facilities

RECOMMENDATION:

It is recommended that the City Council:

- a. Authorize the City Manager to execute a Purchase Order using the Purchasing Association of Cooperative Entities (PACE) competitive purchasing agreement with Lennox Industries Inc. for the purchase of HVAC package units, in an amount of \$45,339 (Attachment "A");
- b. Authorize the City Manager to execute a Services Agreement (Attachment "B" – Contract No. 1806) using the PACE competitive purchasing agreement with Comfort Systems USA (Attachment "C") for the installation and commissioning of HVAC system components, in an amount of \$27,241; and
- c. Establish a contingency of \$11,000 (approximately 15%) for unforeseen conditions associated with this work.

BACKGROUND:

Many of the City's existing HVAC components are antiquated and need replacement. These HVAC components result in higher energy costs and regular ongoing maintenance in order to keep them in operation. As such, staff has initiated a program to begin a phased replacement of HVAC components at facilities based on necessity and budget availability.

With these needs in mind, the City submitted and was awarded grant funding in the amount of \$176,550 through the California Department of Housing and Community Development Housing Related Parks Program Grant to fund improvements at Recreation Park. With a required City matching contribution of \$13,450, the total budget for improvements is \$190,000. Of this amount, approximately \$110,000 was budgeted for HVAC improvements. Replacement HVAC

Consideration to Replace Heating, Ventilation and Cooling System (HVAC) Equipment at City FacilitiesPage 2 of 3

components have been identified and will be installed at a cost below the original grant budget amount.

ANALYSIS:

The existing HVAC components at many City facilities are considered high energy consumers by today's standards. Further, much of our HVAC equipment has exceeded its useful life and requires significant ongoing maintenance in order to keep it in operation. The proposed work would replace old ducting, HVAC components, and electrical equipment with modern, high Seasonal Energy Efficiency Ratio (SEER) package units. By replacing this equipment, it is expected that both energy consumption and ongoing maintenance costs will be reduced.

The proposed replacement equipment is manufactured by Lennox Industries Inc. and was selected by Public Works staff members based on the manufacturer's reputation for producing cost efficient and durable HVAC equipment (Attachment "A"). As proposed, the City would proceed with the following:

1. The purchase of four (4) new 7.5-ton and one (1) 5-ton package units equipped with economizers and modern climate management system functions in the amount of \$41,306, to be funded entirely through grant monies;
2. The purchase of one (1) new 3-ton package unit in the amount of \$4,033 for City Hall using existing general fund monies in the Public Works Department Facilities Division; and
3. The removal of replacement of HVAC components at both facilities in the amount of \$27,241. Of this amount, \$20,725 will be funded through grant funds and \$6,516 will be funded through budgeted general fund monies.

As proposed, the City would purchase and install these HVAC components using a competitive bid through the PACE competitive purchasing agreement (Attachment "B"). The PACE Program is designed to give smaller agencies access to large, competitively priced contracts and help them realize cost savings that they wouldn't have otherwise obtained by bidding alone. The City is a member of the PACE program and is able to utilize the competitive contracts to obtain cost savings. In accordance with the City's Purchasing Policy, the City Council may use a competitive bid conducted by another public agency to purchase goods and services. Known as "Piggybacking" on another contract, this process allows the City to receive the same competitively bid price without having to spend a significant amount of staff time to formally bid and purchase the same goods or services.

Consideration to Replace Heating, Ventilation and Cooling System (HVAC) Equipment at City FacilitiesPage 3 of 3

Schedule

If approved by the City Council, the installation of new HVAC components is expected to take place in late December/early January.

BUDGET IMPACT:

The total estimated cost for these improvements is \$83,580, including contingencies. Funding is included in the City's approved Fiscal Year 2015 budget for HVAC equipment and installation as follows:

- Recreation Park - \$73,031
Funded through grant funding.
- City Hall - \$10,549
Funded through General Fund monies in the Public Works Department budget.

CONCLUSION:

It is recommended that the City Council approve the purchase of replacement HVAC components. These components will help provide the City with more reliable equipment and help reduce energy usage.

ATTACHMENTS:

- A. HVAC Component/Installation Specifications and Pricing Quotations
- B. Contract No. 1806 (Draft Services Agreement)
- C. Purchasing Association of Cooperative Entities (PACE) Competitive Purchasing

LENNOX[®]

Project Quotation

Project Information

Project Name: San Fernando Gym

Project Number: 3000536932

Project Location: SAN FERNANDO, CA 92584, US

Customer Information

Company Name: City of San Fernando

Company Address: 117 MACNEIL ST

Company Location: SAN FERNANDO, CA 91340

Contact:

Phone: 818-896-1893

Fax: 818-898-3221

Engineer Information

Company Name:

Company Address:

Company Location:

Contact:

Phone:

Fax:

We are pleased to provide the attached project quotation. The total quotation price is specific to the bill of materials listed on the quotation. If you have any questions or need additional information, please feel free to call our office.



**RAPID
REPLACEMENT™**

Need replacement equipment fast?

Call Lennox Rapid Replacement 877-792-0024

Continuous **Comfort**
Lennox Commercial Financing

Earn \$500 when your client finances.

Contact Corinne Beyer at 800-606-0049 x140

Lennox Industries Inc. – Project Quotation

Project Name: SFCity

Project Location: SAN FERNANDO, CA 92584, US

Qty	Description	Material
-----	-------------	----------

RTU 92

4	KGA092S4... PKGGE/7.5TON/BTO	KGA092S4-PKG
4	2 Hp Std. Eff. Blower Motor w/MSAV	(Factory)
4	MSAV Belt Drive	(Factory)
4	Standard Cap, Std Packaging	(Factory)
4	Drive Kit 1	(Factory)
4	2in MERV4 Std Filters	(Factory)
4	130KBTU 2-Stage Aluminized Steel	(Factory)
4	Unit Orientation Downflow	(Factory)
4	Unit Refrigerant - R410a	(Factory)
4	208-230 Volt/3 Phase	(Factory)
4	K1ECON22B-1 HIGH PERF ECONOMIZER	10U58
4	C1ACURB30B GCS/CHA16,24823-953	92M73

RTU 60

1	KGA060S4BS PKGGE/5 TON/65KB/230-3	L0914
1	K1ECON32A-1 HIGH PERF ECON-SHORT	10U56
1	C1SNSR60FF1 SINGLE ENTHALPY KIT	10Z75
1	C1ACURB30A GCS10-261,410,650 TO A	83W54

RTU 36

1	KGA036S4BS PKGGE/3 TON/65KB/230-3	L0887
1	CS7500 COMM'L PROGRAMMABLE THERMOSTAT	13H15
1	K1ECON30A-2 ECONOMIZER - SHORT	90W61
1	T1DISC080A-1 80A DISCON TG SHORT	20W17
1	C1ACURB30A GCS/CHA/CHP16/20-511/653 TO T	20W05

CONTROLS

1	C0CTRL10AE1L NETWORK CONTROL PANEL	59L21
1	C0SOFT11AE1- NCP SOFTWARE	96L82
1	C0MISC04AE1- CABLE, LCONN SYSTEM 1000'	94L63
1	C0MISC33AE1M TRANSFORMER, 24VAC, 100VA	27W15
5	C0SNAJ02AE1L CMFRT SNSR ADJST	18W68
5	C0CTRL07AE1L NETWORK T'STAT CTRL	17M10
1	C0MISC43AE1L LCONN ETHERNET CONVERTER	76M77
1	102636-01 M2 USB SERVICE KIT TUBE	59W52

Lennox Industries Inc. – Project Quotation

Notes:

- This quotation is contingent upon the successful contractor meeting all of Lennox Industries standard terms and conditions including satisfactory credit arrangements.
- Payment terms subject to credit review.
- Written permission must be obtained from Lennox for all returns. Returns for standard stocked product are subject to a restocking charge to cover incurred costs. ALL SALES OF SPECIAL ORDER OR CONFIGURED PRODUCTS ARE FINAL. RETURNS WILL NOT BE ALLOWED.
- If all or any portion of an order for special order or configured products is cancelled after production confirmation, the buyer is subject to a cancellation charge.
- All accessories are field installed unless specifically indicated.
- It is the responsibility of the installing contractor to ensure that all installed equipment complies with the governing building codes and energy laws.
- CONTRACTOR TO VERIFY VOLTAGE.
- F.O.B. Point of Shipment, Freight Prepaid to First Destination.
- At the point of delivery, the buyer is responsible for verifying that the product is correct as ordered (model numbers, voltages, etc.) before it is un-crated and/or lifted into place.
- Is this job Tax Exempt? If so please supply a tax exempt form.
- Product must be verified by the contractor to ensure compliance with the current Title 24/ASHRAE 90.1-2010 codes as applicable. NOTE: There are new Title 24/ASHRAE 90.1-2010 requirements for unitary air conditioning equipment and air-handling units with mechanical cooling capacity at ARI conditions greater than or equal to 110,000 Btu/hr that serve single zones. These units MAY require variable supply air volume with their supply fans IF following the prescriptive method for Title 24/ASHRAE 90.1-2010 compliance.
- The State of California energy code Title 24 requires the use of high performance economizers for jobs permitted after 7/1/14. The Lennox factory-installed high performance economizer selection comes with a certificate of compliance to Title 24. Field installed high performance economizers may require jobsite inspections by code officials. Minimum efficiency standards and multi-stage blower capability also apply to Title 24.
- U.S. Dept. of Energy Regional Standards prohibit the install of non-compliant units manufactured after January 1, 2015. Please assure this product is installed in a compliant region.

*

Company Name: City of San Fernando
PROJECT TOTAL SELL PRICE (Tax Not Included): \$41,405.00
***\$3,933.50 Estimated Tax (9.5%)**
\$45,338.50 (Estimated total)

Quote valid from: 11/03/2015 Quote pricing firm to: 12/03/2015

Any use or disclosure of this information to anyone other than the identified Lennox customer, or any use of equipment provided pursuant to this quote for anyone other than the identified Lennox customer, is a breach of the terms under which this information and/or equipment was provided to you, for which you may incur legal liability to Lennox.

TO PLACE AN ORDER, PLEASE FAX THIS QUOTE TO YOUR LENNOX SALES OFFICE OR NATIONAL ACCOUNT DEPARTMENT, COMPLETE WITH THE FOLLOWING INFORMATION:

P.O.#: _____	CUSTOMER ACCOUNT#: _____
SHIP TO: _____	DESIRED DELIVERY DATES: _____
_____	UNITS: _____
_____	CURBS: _____
_____	CONTROLS: _____
_____	VOLTAGE VERIFIED: _____

Lennox Industries Inc. – Project Quotation

SIGNATURE: _____

CALIFORNIA TITLE 24 COMPLIANCE

YES or NO



Product Submittal

Project Information

Project Name: San Fernando Gym

Project Number: 3000536932

Project Location: SAN FERNANDO, CA 92584, US

Project Altitude: 1000

Customer Information

Company Name: City of San Fernando

Company Address: 117 MACNEIL ST

Company Location: SAN FERNANDO, CA 91340

Contact:

Phone: 818-896-1893

Engineering Information

Company Name:

Company Address:

Company Location:

Contact:

Phone:

We are pleased to provide the attached project submittal. If you have any questions or need additional information, please feel free to call our office.

Lennox Industries Inc. - Product Submittal

Table of Contents

System ID	Qty	Model	Description
RTU 92	4	KGA092S4M	PKGGE/7.5TON/BTO
RTU 60	1	KGA060S4B	PKGGE/5 TON/65KB/230-3

Lennox Industries Inc. - Product Submittal

System ID: RTU 92

Package Model: KGA092S4M

Description: PKGGE/7.5TON/BTO

HEATING PERFORMANCE

Unit Type	Packaged Gas Electric	Gas Supply Connection	0.75 (in.)
H/E LowInput	84500 (Btuh)	H/E Heat Rise	32.1 (°F)
H/E LowOutput	67500 (Btuh)	AFUE/ ThermalEff	80
H/E HighInput	130000 (Btuh)	Number of Heating Stages	2
H/E HighOutput	104000 (Btuh)	Gas Supply Pressure	7 (in.WC)
System HeatOutput	104000 (Btuh)		

COOLING PERFORMANCE

Refrigerant	R-410A	Number Compressors	2
ARI EER	11.0	Number of Cooling Stages	2
ARI IEER	13.0	Condensate Drain Size	1.00 (in.)
ARI Total Power	7800 (W)	Cooling OutdoorDB	95.0 (°F)
ARI GrossTotalCool	88200 (Btuh)	Cooling MixedDB	80.0 (°F)
ARI NetTotalCool	86000 (Btuh)	Cooling MixedWB	67.0 (°F)

SUPPLY FAN PERFORMANCE

ExtStaticPress Supply	0.80 (in.WC)	TotalStaticPress	0.93 (in.WC)
SupplyFan NomPower	2.00 (hp)	Economizer Static Press	0.13 (in.WC)
Supply Fan Type	MSAV Belt Drive	Air Filter Qty	4
SupplyDrive Min RPM	590 (rpm)	Air Filter Length	20.0 (in.)
SupplyDrive Max RPM	890 (rpm)	Air Filter Width	25.0 (in.)
		Air Filter Thickness	2.0 (in.)

ELECTRICAL

Voltage	208V 3Ph	SupplyFan FLA	7.5 (amp)
Frequency	60 (Hz)	CondensingUnit FLA	4.8 (amp)
System MCA	38.0 (amp)	CondenserFan Power	740 (W)
System MOCP	50 (amp)		
Compressors RLA	26.2 (amp)		
Cooling FLA Total	38.5 (amp)		
Unit Oper Range-Nom Voltage	+/- 10%		

DIMENSIONS

Cabinet Width	60.1 (in.)	Downflow Supply Length	20.0 (in.)
Cabinet Length	101.3 (in.)	Downflow Supply Width	28.0 (in.)
Cabinet Height	46.9 (in.)	Downflow Return Length	24.0 (in.)
Total Weight	991 (lb)	Downflow Return Width	27.0 (in.)

SOUND

Outdoor Sound Rating	88 (db)
----------------------	---------

Lennox Industries Inc. - Product Submittal

System ID: RTU 92	Description: PKGGE/7.5TON/BTO
Package Model: KGA092S4M	

SYSTEM FEATURES

Durable Outdoor Enamel Paint Finish	See Limited Warranty Certificate included with unit for details
Scroll Compressor	AGA-CGA Certified
High Capacity Driers	Redundant Comb. Gas Control Valve
Separate Compressor and Controls Compartment	Electronic Flame Sensor
Limited compressor warranty of 5 years	Direct Spark Ignition
Limited warranty on all other components of 1 year	Limited warranty on Environ Coil System of 3 years

INCLUDED SYSTEM OPTIONS - FACTORY INSTALLED

MULTI-STAGE AIR VOLUME BELT DRIVE
2 IN MERV4 FILTER

INCLUDED SYSTEM OPTIONS - FIELD INSTALLED

10U58	4	K1ECON22B-1 HIGH PERF ECONOMIZER
-------	---	----------------------------------

Lennox Industries Inc. - Product Submittal

System ID: RTU 92

Package Model: KGA092S4M

Description: PKGGE/7.5TON/BTO

DIMENSIONS - INCHES (MM)

Model No.	CORNER WEIGHTS								CENTER OF GRAVITY															
	AA		BB		CC		DD		EE		FF													
	Base	Max.	Base	Max.	Base	Max.	Base	Max.	Base	Max.	Base	Max.	in.	mm	in.	mm								
092	248	113	292	133	223	101	255	116	243	110	273	124	276	125	320	145	47	1181	46	1156	24.5	622	25.5	648
102	253	115	297	135	228	103	260	118	248	112	278	126	282	128	326	148	47	1181	46	1156	24.5	622	25.5	648
120	263	119	308	140	237	107	269	122	258	117	288	130	293	133	337	153	47	1181	46	1156	24.5	622	25.5	648
150	286	130	331	150	257	117	289	131	280	127	309	140	318	144	362	164	47	1181	46	1156	24.5	622	25.5	648

Base Unit - The unit with NO OPTIONS.

Max. Unit - The unit with ALL OPTIONS installed. (Economizer, etc.)

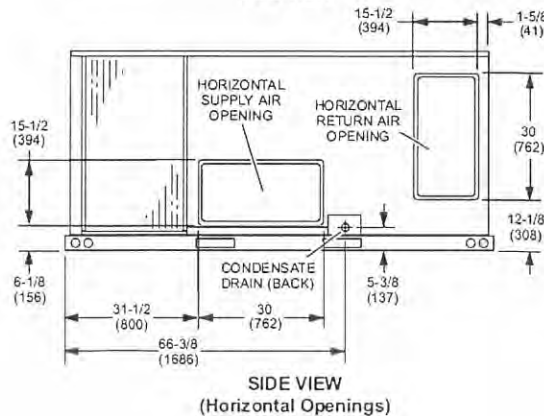
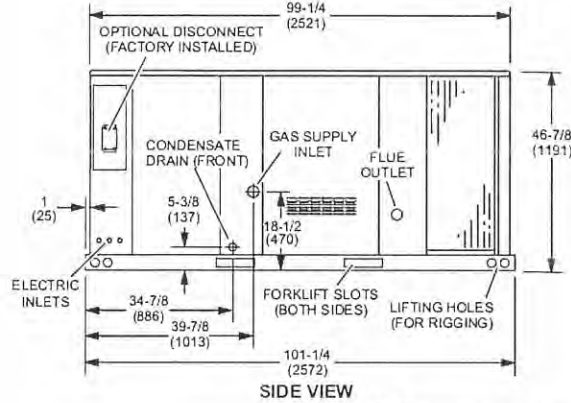
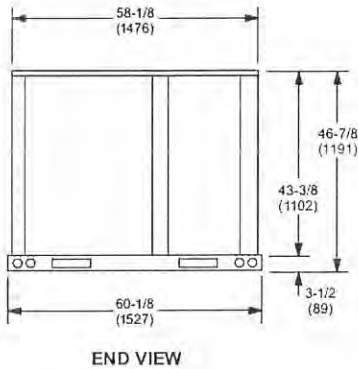
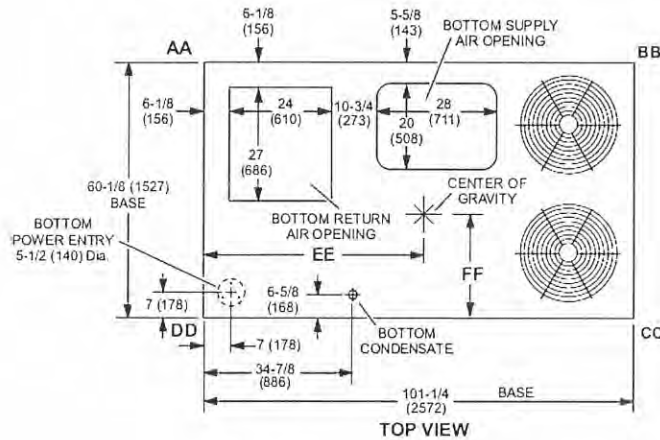

Lennox Industries Inc. - Product Submittal

System ID: RTU 92

Package Model: KGA092S4M

Description: PKGGE/7.5TON/BTO

ACCESSORY DIMENSIONS - INCHES (MM)

OUTDOOR AIR HOOD DETAIL

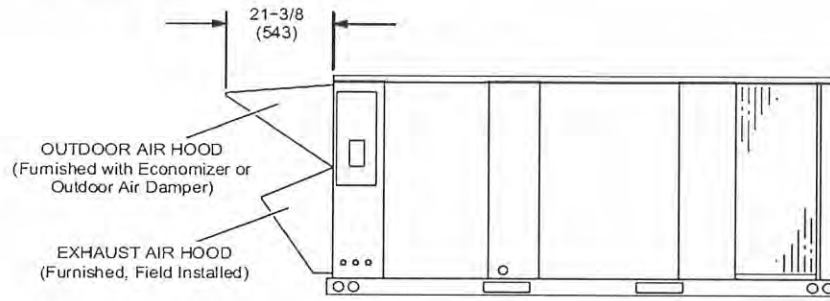

Lennox Industries Inc. - Product Submittal

System ID: RTU 92

Package Model: KGA092S4M

Description: PKGGE/7.5TON/BTO

UNIT CLEARANCES - INCHES (MM)

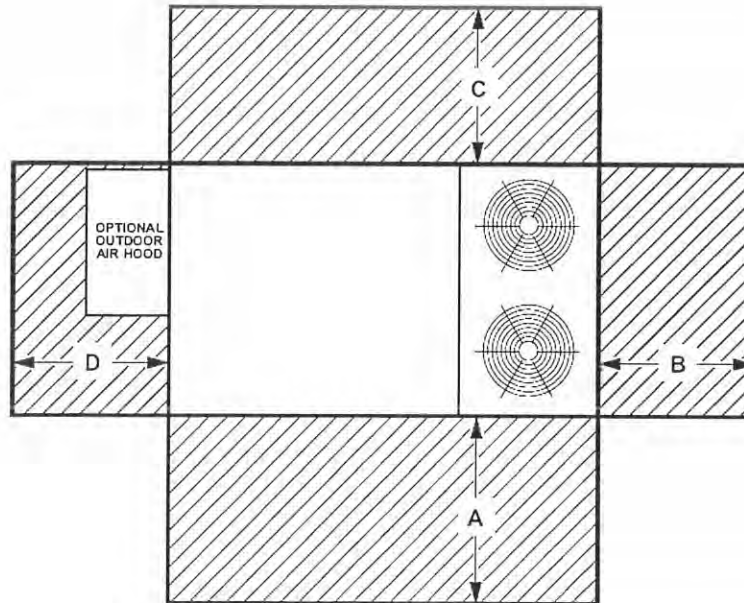

Unit Clearance	A		B		C		D		Top Clearance
	in.	mm	in.	mm	in.	mm	in.	mm	
Service Clearance	60	1524	36	914	36	914	60	1524	Unobstructed
Clearance to Combustibles	36	914	1	25	1	25	1	25	
Minimum Operation Clearance	36	914	36	914	36	914	36	914	

NOTE - Entire perimeter of unit base requires support when elevated above the mounting surface.

¹ Service Clearance - Required for removal of serviceable parts.

Clearance to Combustibles - Required for clearance to combustible material.

Minimum Operation Clearance - Required clearance for proper unit operation.

Lennox Industries Inc. - Product Submittal

System ID: RTU 60

Package Model: KGA060S4B

Description: PKGGE/5 TON/65KB/230-3

HEATING PERFORMANCE

Unit Type	Packaged Gas Electric	Gas Supply Connection	0.50 (in.)
H/E HighInput	65000 (Btuh)	H/E Heat Rise	24.1 (°F)
H/E HighOutput	52000 (Btuh)	AFUE/ ThermalEff	80
System HeatOutput	52000 (Btuh)	Number of Heating Stages	1
		Gas Supply Pressure	7 (in.WC)

COOLING PERFORMANCE

Refrigerant	R-410A	Number Compressors	1
ARI EER	11.2	Number of Cooling Stages	1
ARI SEER	13.0	Condensate Drain Size	1.00 (in.)
ARI Total Power	5300 (W)	Cooling OutdoorDB	95.0 (°F)
ARI GrossTotalCool	61800 (Btuh)	Cooling MixedDB	80.0 (°F)
ARI NetTotalCool	59000 (Btuh)	Cooling MixedWB	67.0 (°F)

SUPPLY FAN PERFORMANCE

ExtStaticPress Supply	0.80 (in.WC)	TotalStaticPress	0.85 (in.WC)
SupplyFan NomPower	1.00 (hp)	Economizer Static Press	0.05 (in.WC)
Supply Fan Type	CAV Belt Drive	Air Filter Qty	4
SupplyDrive Min RPM	833 (rpm)	Air Filter Length	16.0 (in.)
SupplyDrive Max RPM	1250 (rpm)	Air Filter Width	20.0 (in.)
		Air Filter Thickness	2.0 (in.)

ELECTRICAL

Voltage	208V 3Ph	SupplyFan FLA	4.6 (amp)
Frequency	60 (Hz)	CondensingUnit FLA	2.4 (amp)
System MCA	24.0 (amp)	CondenserFan Power	370 (W)
System MOCP	35 (amp)		
Compressors RLA	13.5 (amp)		
Cooling FLA Total	20.5 (amp)		
Unit Oper Range-Nom Voltage	+/- 10%		

DIMENSIONS

Cabinet Width	47.0 (in.)	Downflow Supply Length	18.0 (in.)
Cabinet Length	83.3 (in.)	Downflow Supply Width	20.0 (in.)
Cabinet Height	36.4 (in.)	Downflow Return Length	11.0 (in.)
Total Weight	732 (lb)	Downflow Return Width	29.0 (in.)

SOUND

Outdoor Sound Rating	82 (db)
----------------------	---------

Lennox Industries Inc. - Product Submittal

System ID: RTU 60	Description: PKGGE/5 TON/65KB/230-3
Package Model: KGA060S4B	

SYSTEM FEATURES

Durable Outdoor Enamel Paint Finish	See Limited Warranty Certificate included with unit for details
Scroll Compressor	AGA-CGA Certified
High Capacity Driers	Redundant Comb. Gas Control Valve
Separate Compressor and Controls Compartment	Electronic Flame Sensor
Limited compressor warranty of 5 years	Direct Spark Ignition
Limited warranty on all other components of 1 year	

INCLUDED SYSTEM OPTIONS - FACTORY INSTALLED

CONSTANT AIR VOLUME BELT DRIVE
2 IN MERV4 FILTER

INCLUDED SYSTEM OPTIONS - FIELD INSTALLED

10U56	1	K1ECON32A-1 HIGH PERF ECON-SHORT
10Z75	1	C1SNSR60FF1 SINGLE ENTHALPY KIT

Lennox Industries Inc. - Product Submittal

System ID: RTU 60

Package Model: KGA060S4B

Description: PKGGE/5 TON/65KB/230-3

DIMENSIONS - INCHES (MM)

Model No.	CORNER WEIGHTS								CENTER OF GRAVITY															
	AA		BB		CC		DD		EE		FF		Max.											
	Base lbs.	Max. kg	Base lbs.	Max. kg	Base lbs.	Max. kg	Base lbs.	Max. kg	Base in.	Max. mm	Base in.	Max. mm	Base in.	Max. mm										
024	92	42	113	52	112	51	128	58	180	82	207	94	148	67	183	83	38-1/2	978	40	1016	18	457	18	457
030	92	42	114	52	112	51	129	58	180	82	207	94	149	68	183	83	38-1/2	978	40	1016	18	457	18	457
036	92	42	114	52	112	51	129	59	181	82	208	94	149	68	184	83	38-1/2	978	40	1016	18	457	18	457
048	99	45	123	56	120	55	139	63	193	88	223	102	159	72	197	90	38-1/2	978	40	1016	18	457	18	457
060	104	47	128	58	126	57	145	66	203	92	233	106	167	76	206	94	38-1/2	978	40	1016	18	457	18	457
072	121	55	143	65	147	67	162	74	237	108	261	119	195	89	231	105	38-1/2	978	40	1016	18	457	18	457
090	168	76	195	88	183	83	212	96	227	103	263	119	203	95	241	109	47	1194	47	1194	21	533	21	533

Base Unit - The unit with standard heat exchanger NO OPTIONS.

Max. Unit - The unit with ALL OPTIONS installed. (High Input Heat Exchanger, Economizer, etc.)

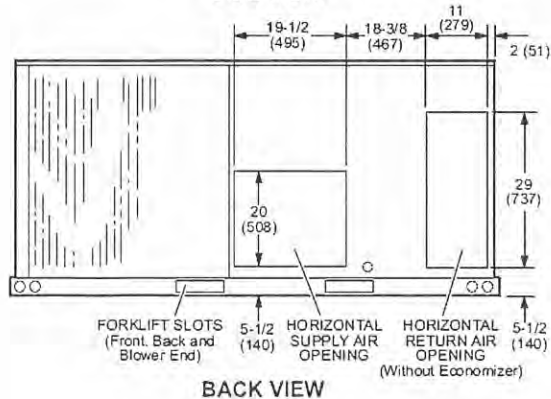
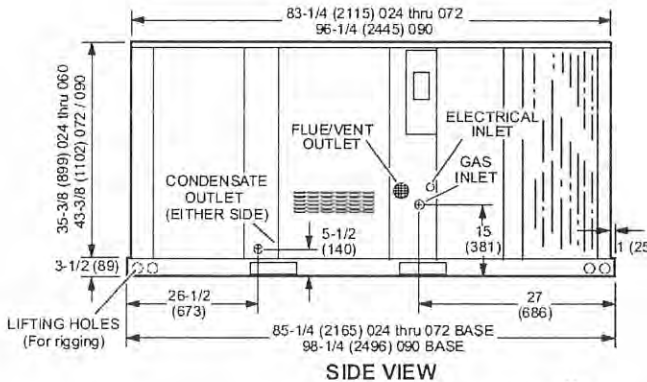
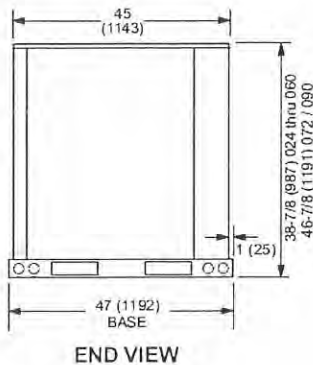
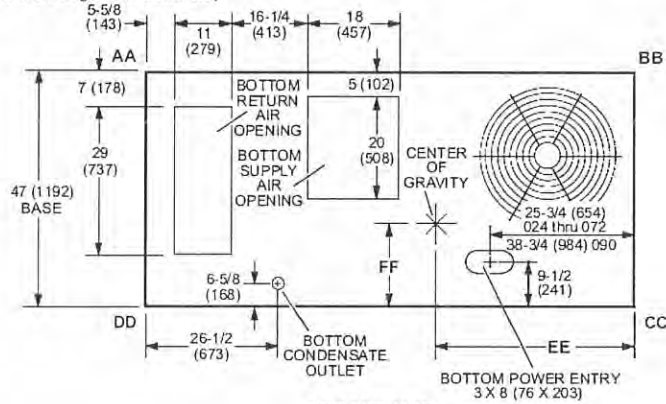

Lennox Industries Inc. - Product Submittal

System ID: RTU 60

Package Model: KGA060S4B

Description: PKGGE/5 TON/65KB/230-3

DIMENSIONS - ACCESSORIES - INCHES (MM)

OUTDOOR AIR HOOD DETAIL FOR OPTIONAL ECONOMIZER AND BAROMETRIC RELIEF DAMPERS (Downflow Applications)

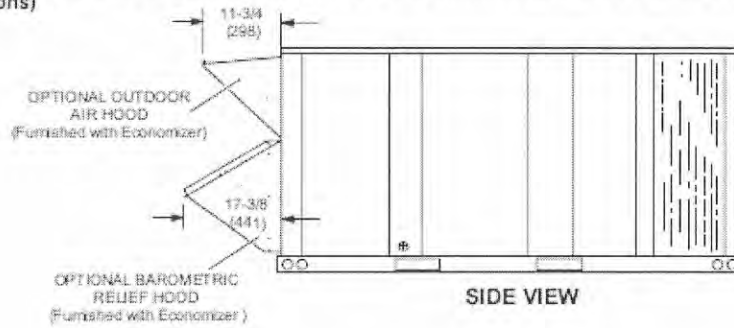

OUTDOOR AIR HOOD FOR ECONOMIZER (Furnished)

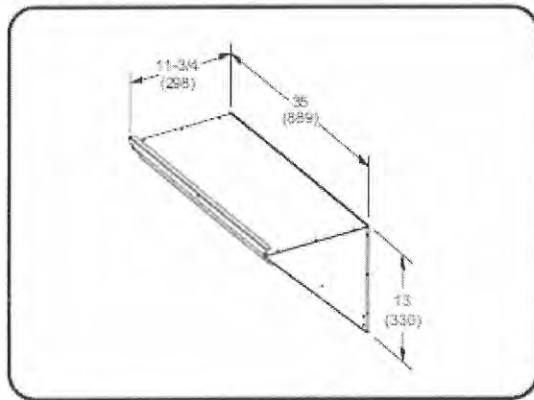

BAROMETRIC RELIEF HOOD FOR ECONOMIZER (Furnished)

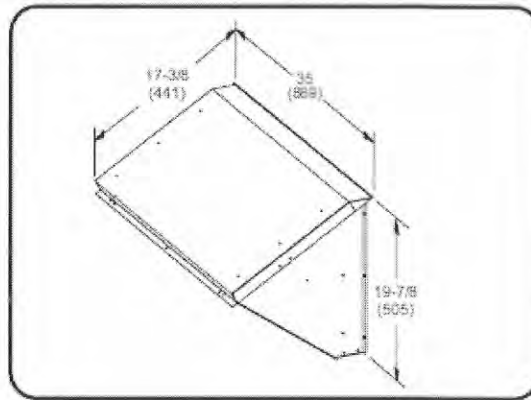

OUTDOOR AIR DAMPER HOOD DETAIL FOR OPTIONAL MANUAL OR MOTORIZED OUTDOOR AIR DAMPERS (Downflow or Horizontal Applications)

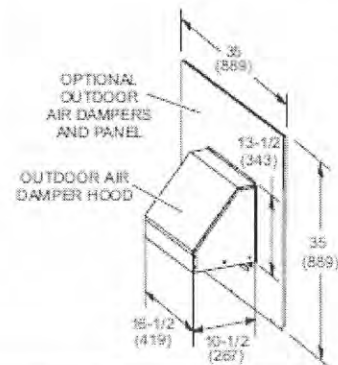
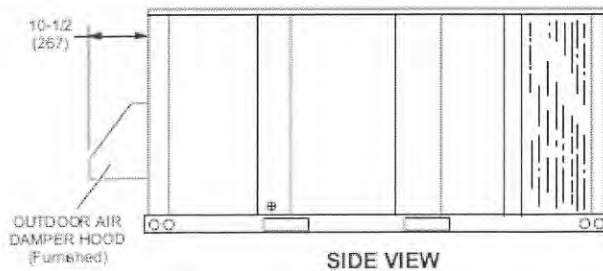

Lennox Industries Inc. - Product Submittal

System ID: RTU 60 Package Model: KGA060S4B	Description: PKGGE/5 TON/65KB/230-3
---	-------------------------------------

UNIT CLEARANCES - INCHES (MM)

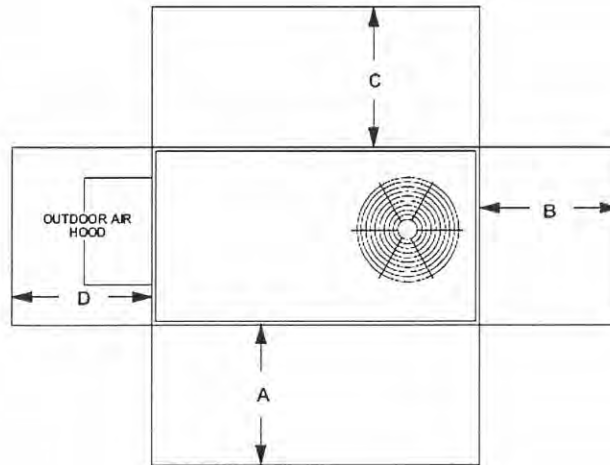

1 Unit Clearance	A		B		C		D		Top Clearance
	in.	mm	in.	mm	in.	mm	in.	mm	
Service Clearance	48	1219	36	914	36	914	36	914	Unobstructed
Clearance to Combustibles	36	914	1	25	1	25	1	25	
Minimum Operation Clearance	36	914	36	914	36	914	36	914	

NOTE - Entire perimeter of unit base requires support when elevated above the mounting surface.
 1 Service Clearance - Required for removal of serviceable parts.
 Clearance to Combustibles - Required clearance to combustible material.
 Minimum Operation Clearance - Required clearance for proper unit operation.

Lennox Industries Inc. - Product Submittal

MISCELLANEOUS MATERIALS

92M73
83W54

C1ACURB30B GCS/CHA16,24823-953
C1ACURB30A GCS10-261,410,650 TO A



4189 Santa Ana Street, Suite D, Ontario, CA 91761 Office (909) 390-6677 Fax (909) 390-6648
California Contractors License # 931867

PROJECT SITE:

**City of San Fernando
117 North Macneil St.
San Fernando, CA 91340**

CUSTOMER:

**City of San Fernando
117 North Macneil St.
San Fernando, CA 91340**

DATE: 11/05/2015

RE: **INSTALL NEW LENNOX HVAC EQUIPMENT AS LISTED:**

City Hall – 117 N. Macneil St:

- One (1) 3-Tons Packaged Gas RTU Model (KGA036S4B)
- Scroll Compressor
 - R-410 Refrigerant
 - High Capacity Driers
 - Separate Compressor and Controls Compartment
 - Redundant Comb. Gas Control Valve
 - Vertical Downflow Supply & Return w/ Economizer
 - AGA-CGA Certified
 - Electrical Configuration (208/3/60)

Recreation Center – 208 Park Ave:

- One (1) 5-Tons Packaged Gas RTU Model (KGA060S4B)
Four (4) 7.5-Tons Packaged Gas RTU Model (KGA092S4M)
- Scroll Compressor
 - R-410 Refrigerant
 - High Capacity Driers
 - Separate Compressor and Controls Compartment
 - AGA-CGA Certified
 - Redundant Comb. Gas Control Valve
 - 2" MERV4 Filter
 - Electrical Configuration (230/3/60)



4189 Santa Ana Street, Suite D, Ontario, CA 91761 Office (909) 390-6677 Fax (909) 390-6648
California Contractors License # 931867

Scope of Work:

Demo:

- Provide crane and necessary rigging for removal of:
- City Hall: One (3) Tons RTU (See Attached Plan View).
- Recreation Center: One (5) Tons & Four (7.5) Tons RTU (See Attached Plan View).
- Disconnect and safe-off existing electrical.
- Disconnect existing low voltage / controls wiring.
- Disconnect existing condensate drain lines back to point of connection (P.O.C.)
- Disconnect units from existing supply and return ductwork at unit P.O.C. (as required).
- Disconnect existing controls and Fire Life Safety (FLS).
- Salvage rights from existing equipment demo to Comfort Systems USA.
- Clean up area and remove any miscellaneous debris.

Installation:

- Provide crane and necessary rigging for installation of:
- Equipment purchased and provided by customer as listed under equipment.
- Provide and install new low voltage flexible conduits and connect to existing P.O.C's.
- Provide and install new PVC Schedule 80 condensate piping and connect to existing Point of Connection (P.O.C.) where applicable.
 - Install new 3/4" union for easy cleanout
- Verify any ductwork seams at roof (P.O.C) and seal per SMACNA standards.
- Install new Title 24 compliant programmable thermostat.
- Install new Lennox Comfort Sensor Zoning Kit w/ L-Connection Network (provided by customer).
- Reconnect any existing FLS smoke detectors.
- Provide a turn-over package, to include:
 - Warranty documents
 - Factory Start-up Sheets
 - Operation and Maintenance Manuals



4189 Santa Ana Street, Suite D, Ontario, CA 91761 Office (909) 390-6677 Fax (909) 390-6648
California Contractors License # 931867

Clarifications:

- Provide approved mechanical permits from the City of San Fernando, CA.
- All main work to be completed during regular hours (7:00am to 4:00pm).
- This proposal is intended to replace like for like HVAC units. Engineering for Title 24 and structural is a separate line item and additional costs will incur.
- If structural is required by city for permit purposes additional cost will incur.
- Existing smoke detectors will not be replaced. Existing components to be reconnected.
- All replacement equipment and controls are to be provided by customer. Any time loss for correction of nonconforming systems provided will be at additional costs.
- Comfort Systems USA assumes no responsibility for the operation or performance of any existing equipment or new system capabilities in meeting customer requirements regardless of our contractual scope that relocates, modifies, and or connects to these existing devices or systems.
- Customer must provide site safety ingress and egress to coordinate foot and vehicle traffic.

Exclusions:

- Permits or fees other than stated in the above scope including Plan Check and HERS TESTING
- If structural engineering is required by city for permit purposes additional cost will incur.
- Any structural upgrades / framing / platforms or sheet metal caps (quoted separately).
- Exhaust fans / curbs.
- Holiday / Special Work Hours Requested by Customer.
- Any DDC controls modifications and /or upgrades unless stated above.
- Electrical service or connections, replacement or upgrade of panel.
- Existing equipment or component integrity.
- Temporary Air Conditioning.
- Asbestos monitoring, abatement or any hazardous materials.
- Any upgrades that might be required to bring up to new city codes.
- Mechanical / Electrical / Structural engineered drawings.
- Any high voltage electrical scope.
- Any Fire Life Safety / Smoke detectors/Fire protection.
- Any Electrical or 120VAC convenience outlets at existing unit.
- Coring / Patching or Painting.
- Certified air balance unless otherwise stated above.
- Duct cleaning of existing ductwork.
- Roofing / Demo of roofing or any repairs.
- Any OSHA upgrades.
- Customer must provide site safety ingress and egress to coordinate foot and vehicle traffic.
- Any additional equipment repairs, modifications, service, start up, maintenance and testing of any existing equipment or systems will result in an additional charge.
- Anything not specifically included in installation.



4189 Santa Ana Street, Suite D, Ontario, CA 91761 Office (909) 390-6677 Fax (909) 390-6648
California Contractors License # 931867

Thank you for allowing Comfort Systems USA Southwest to provide the following proposal for the installation of new HVAC equipment to your building.

Project Cost: \$ 27,241.00
(Twenty Seven Thousand Two Hundred Forty One Dollars)

Job Start: Upon Approval and Equipment Lead Time of 6 – 8 Weeks

Completion: 2 - 3 days

Warranty: One (1) year warranty on materials and labor scope performed by Comfort Systems USA Southwest only.

Proposed By: Comfort Systems USA Southwest	Approved By:
Name: Arthur Quinones Arthur.quinones@comfortsystemsusa.com	Name:
Signature: <i>Arthur Quinones</i>	Title:
Title: HVAC Project / Service Development	Date:
Date: 11/05/2015	
Contact Art Quinones O: (909) 390-6677 / C: (714) 474-6178	Price valid for 30 days from date of proposal.



4189 Santa Ana Street, Suite D, Ontario, CA 91761 Office (909) 390-6677 Fax (909) 390-6648
 California Contractors License # 931867

GENERAL CONDITIONS

1. CSUSA warrants that the workmanship hereunder shall be free from defects for (365) days from date of installation. If any replacement part or item of equipment proves defective, CSUSA will extend to Customer the benefits of any warranty CSUSA has received from the manufacturer. Removal and reinstallation of any equipment or materials repaired or replaced under a manufacturer's warranty will be at Customer's expense and at the rates then in effect if beyond CSUSA workmanship warranty.
2. Customer shall permit CSUSA free and timely access to areas and equipment, and allow CSUSA to start and stop the equipment as necessary to perform required service. All planned work under this Agreement will be performed during CSUSA's normal working hours (M-F, 7:00 am – 4:00 pm).
3. Customer will promptly pay invoices within thirty (30) days of receipt. Should a payment become thirty (30) days or more delinquent, CSUSA may stop all work under this Agreement without notice and/or cancel this Agreement, and the entire Agreement amount shall become due and payable immediately upon demand.
4. Customer shall be responsible for all taxes applicable to the services and/or materials hereunder.
5. Any alteration to, or deviation from, this Agreement involving extra work, cost of material or labor will become an extra charge (fixed-price amount to be negotiated or on a time-and-material basis at CSUSA's rates then in effect) over the sum stated in this Agreement.
6. In the event CSUSA must commence legal action in order to recover any amount payable under this Agreement, Customer shall pay CSUSA all court costs and attorneys' fees incurred by CSUSA.
7. Any legal action relating to this Agreement, or the breach thereof, shall be commenced within one (1) year from the date of the work.
8. CSUSA shall not be liable for any delay, loss, damage or detention caused by unavailability of machinery, equipment or materials, delay of carriers, strikes, including those by CSUSA's employees, lockouts, civil or military authority, priority regulations, insurrection or riot, action of the elements, forces of nature, or by any cause beyond its control.
9. To the fullest extent permitted by law, Customer shall indemnify and hold harmless CSUSA, its agents and employees from and against all claims, damages, losses and expenses, including but not limited to attorney's fees, arising out of or resulting from the performance of work hereunder, provided that such claim, damage, loss or expense is caused in whole or in part by any active or passive act or omission of customer, anyone directly or indirectly employed by customer, or anyone for whose acts Customer may be liable, regardless of whether it is caused in part by the negligence of CSUSA.
10. UNDER NO CIRCUMSTANCES, WHETHER ARISING IN CONTRACT, TORT (INCLUDING NEGLIGENCE), EQUITY OR OTHERWISE, WILL CSUSA BE RESPONSIBLE FOR LOSS OF USE, LOSS OF PROFIT, INCREASED OPERATING OR MAINTENANCE EXPENSES, CLAIMS OF CUSTOMER'S TENANTS OR CLIENTS, OR ANY SPECIAL, INDIRECT OR CONSEQUENTIAL DAMAGES.

Billable Purchase Order # _____ Initials _____ Date _____

*** Please return initialed document with proposal to
 Comfort Systems USA
 Fax # (909) 390-6648
 e-mail arthur.quinones@comfortsystemsusa.com**



ATTACHMENT "B"
CONTRACT NO. 1806

2015

PROFESSIONAL SERVICES AGREEMENT

Outreach and Planning Services to Install HVAC Components/Equipment for the City of San Fernando
 Comfort Systems USA

THIS 2013 PROFESSIONAL SERVICES AGREEMENT ("Agreement") is entered into this 7th day of December 2015 (hereinafter, the "Effective Date"), by and between the CITY OF SAN FERNANDO, a municipal corporation and general law city ("CITY") and Comfort Systems USA (hereinafter, "CONSULTANT"). The capitalized term "Parties" shall be a collective reference to both CITY and CONSULTANT. The capitalized term "Party" shall refer to either CITY or CONSULTANT interchangeably as appropriate.

RECITALS

THIS AGREEMENT is made and entered into with respect to the following facts:

WHEREAS, CITY, pursuant to California Government Code Sections 37103 and 53060, is authorized and empowered to contract with any specially trained and experienced firm or corporation for special services and advice on financial, economic, accounting, engineering, legal or administrative matters; and

WHEREAS, CITY's in-house personnel are not able to provide the types of specialized consulting services required under this engagement; and

WHEREAS, CITY require the performance of **HVAC Installation** services in connection with the **City HVAC Replacement Project**; and

WHEREAS, CONSULTANT represents that it is fully qualified to perform such professional services by virtue of its experience and the training, education and expertise of its principals, employees and subcontractors; and

WHEREAS, the execution of this Agreement was approved by the City Council in accordance with the CITY's procurement and purchasing procedures at the City Council's meeting of December 7, 2015 under Agenda Item [REDACTED]; and

WHEREAS, CONSULTANT further represents that it is willing to accept responsibility for performing such services in accordance with the terms and conditions set forth in this Agreement.

NOW, THEREFORE, FOR AND IN CONSIDERATION OF THE MUTUAL COVENANTS AND CONDITIONS HEREIN CONTAINED, CITY AND CONSULTANT AGREE AS FOLLOWS:

I.

SCOPE AND PROSECUTION OF WORK; COMPENSAITON

1.1 SCOPE OF WORK: Subject to the terms and conditions set forth in this Agreement and all exhibits attached and incorporated hereto, CONSULTANT agrees to perform the services and tasks set forth in that certain proposal entitled **HVAC Installation for the City of San Fernando** and dated as of [REDACTED] 20[REDACTED] which is attached and incorporated hereto **Exhibit "A"** (hereinafter the "Scope of Work"). CONSULTANT further agrees to furnish to CITY all labor, materials, tools, supplies, equipment, services, tasks and incidental and customary work necessary to competently perform and timely complete the services and tasks set forth in the Scope of Work. For the purposes of this Agreement the aforementioned services and tasks set forth in the Scope of Work shall hereinafter be referred to generally by the capitalized term "Work." The Work is inclusive of those tasks that may be identified as being optional under the Scope of Work and such optional work

shall not constitute Extra Work under Section 1.5 of this Agreement, below. Neither CONSULTANT nor anyone acting on CONSULTANT's behalf shall commence with the performance of the Work or any other related tasks until CITY issues a written notice to proceed (hereinafter, the "Notice to Proceed").

1.2 TERM:

- A. This Agreement shall have a term of six (6) months commencing from the **Effective Date** (hereinafter, the "Initial Term").
- B. This Agreement may be extended subject to the same terms and conditions set forth herein for a maximum of two (2) six (6) **month** extension terms, in the sole and absolute discretion of CITY, provided CITY issues written notice of its intent to so extend the Agreement no less than thirty (30) calendar days prior to the expiration of the Initial Term or any subsequent extension term. Nothing in this subsection shall operate to prohibit or otherwise restrict CITY right to terminate this Agreement at any time for convenience or for cause as provided herein.
- C. Nothing in this Section shall operate to prohibit or otherwise restrict the CITY's ability to terminate this Agreement at any time for convenience or for cause.

1.3 COMPENSATION AND COMPENSATION CONTROLS:

- A. CONSULTANT shall perform and complete all of the services and tasks set forth under the Scope of Work at the rates of compensation set forth in that certain compensation schedule set forth under **[page XX/Section XX]** of the Scope of Work under the heading "**Fees**" (hereinafter, the "Compensation Schedule"). CONSULTANT shall also receive reimbursement for those pass-through costs and expenses specifically identified in the Compensation Schedule as being reimbursable pass-through costs, except that any such costs which are anticipated to be in excess of \$500.00 shall require the prior written approval of the General Manager or designee before they are incurred. For purposes of this Agreement, those pass-through costs or expenses identified as being reimbursable under the Compensation Schedule may hereinafter be referred to as "Reimbursable Costs". CONSULTANT shall provide copies of receipts and invoices corroborating all costs or expenses, including Reimbursable Costs, indicated in CONSULTANT's monthly invoice or statement. CITY shall be under no obligation to reimburse CONSULTANT for unsubstantiated costs or expenses.
- B. Subsection (A) of this Section notwithstanding, in no event may CONSULTANT's total compensation for the performance and completion of the Work exceed the aggregate sum of fifty-seven thousand one hundred fifty Dollars (\$27,241) during the entire Initial Term of the Agreement or during any single extension term ("Contract Price).
- C. In so far as CONSULTANT seeks reimbursement for costs and expenses other than those that qualify as Reimbursable Expenses, such costs or expenses shall be deducted against the **Not-to-Exceed Sum**.

1.4 PAYMENT OF COMPENSATION:

- A. CITY shall compensate CONSULTANT on a monthly basis as tasks are performed and the Work is completed to the reasonable satisfaction of CITY. Following the conclusion of each month during the Initial Term of this Agreement or any extension term, CONSULTANT shall submit to CITY a monthly itemized invoice or statement identifying the tasks performed, hours of service rendered and reimbursable pass-through costs incurred by CONSULTANT and its various employees during the recently concluded month.
- B. Within thirty (30) calendar days of receipt of each invoice, CITY shall notify CONSULTANT in writing of any disputed charges, costs or expenses included in the invoice. Within forty-five (45)

calendar days of receipt of each invoice, CITY shall pay all undisputed charges, costs and expenses indicated in CONSULTANT's monthly invoice.

- C. CITY shall not withhold applicable taxes or other authorized deductions from payments made to CONSULTANT.

1.5 EXTRA WORK; COMPENSATION FOR EXTRA WORK:

- A. At any time during the term of this Agreement, CITY may request that CONSULTANT perform Extra Work. For the purposes of this Agreement, the term "Extra Work" means any additional work, services or tasks not set forth in the Scope of Work but later determined by CITY to be necessary. CONSULTANT shall not undertake nor shall CONSULTANT be entitled to compensation for Extra Work without the prior written authorization of the CITY. Extra Work does not include any labor, materials, tools, supplies, equipment, services, tasks or incidental and customary work undertaken to competently perform and timely complete the Work and related tasks set forth in the Scope of Work.
- B. Payments for any Extra Work shall be made to CONSULTANT on a time-and-materials basis using CONSULTANT's standard fee schedule.

- 1.6 ACCOUNTING RECORDS: CONSULTANT shall maintain complete and accurate records with respect to all matters covered under this Agreement for a period of three (3) years after the expiration or termination of this Agreement. CITY shall have the right to access and examine such records, without charge, during normal business hours. CITY shall further have the right to audit such records, to make transcripts therefrom and to inspect all program data, documents, proceedings, and activities.

- 1.7 ABANDONMENT BY CONSULTANT: In the event CONSULTANT ceases to perform the Work agreed to under this Agreement or otherwise abandons the undertaking contemplated herein prior to the expiration of this Agreement or prior to completion of any or all tasks set forth in the Scope of Work, CONSULTANT shall deliver to CITY immediately and without delay, all materials, records and other work product prepared or obtained by CONSULTANT in the performance of this Agreement. Furthermore, CONSULTANT shall only be compensated for the reasonable value of the services, tasks and other work performed up to the time of cessation or abandonment, less a deduction for any damages, costs or additional expenses which CITY may incur as a result of CONSULTANT's cessation or abandonment.

II.
PERFORMANCE OF AGREEMENT

- 2.1 CITY'S REPRESENTATIVES: The CITY hereby designates **Deputy City Manager** (hereinafter, the "CITY Representatives") to act as its representatives for the performance of this Agreement. The CITY Representatives or their designee shall act on behalf of the CITY for all purposes under this Agreement. CONSULTANT shall not accept directions or orders from any person other than the CITY Representatives or their designee.

2.2 CONSULTANT'S REPRESENTATIVE: CONSULTANT hereby designates [Insert Name and Title of Person who will be Representing Consultant in the Performance and Administration of this Agreement] to act as its representative for the performance of this Agreement (hereinafter, "Consultant's Representative"). CONSULTANT's Representative shall have full authority to represent and act on behalf of the CONSULTANT for all purposes under this Agreement. Consultant's Representative or his designee shall supervise and direct the performance of the Work, using his/her best skill and attention, and shall be responsible for all means, methods, techniques, sequences and procedures and for the satisfactory coordination of all portions of the Work under this Agreement. Notice to the Consultant's Representative shall constitute notice to CONSULTANT.

2.3 COORDINATION OF SERVICE; CONFORMANCE WITH REQUIREMENTS: CONSULTANT agrees to work closely with CITY staff in the performance of the Work and this Agreement and shall be available to CITY staff and the CITY Representatives at all reasonable times. All work prepared by CONSULTANT shall be subject to inspection and approval by CITY Representatives or their designees.

2.4 STANDARD OF CARE; PERFORMANCE OF EMPLOYEES: CONSULTANT represents, acknowledges and agrees to the following:

- A. CONSULTANT shall perform all work skillfully, competently and to the highest standards applicable to the CONSULTANT's profession;
- B. CONSULTANT shall perform all work in a manner reasonably satisfactory to the CITY;
- C. CONSULTANT shall comply with all applicable federal, state and local laws and regulations, including the conflict of interest provisions of Government Code Section 1090 and the Political Reform Act (Government Code Section 81000 *et seq.*);
- D. CONSULTANT understands the nature and scope of the Work to be performed under this Agreement as well as any and all schedules of performance;
- E. All of CONSULTANT's employees and agents (including but not limited to CONSULTANT's subcontractors and subconsultants) possess sufficient skill, knowledge, training and experience to perform those services and tasks assigned to them by CONSULTANT; and
- F. All of CONSULTANT's employees and agents (including but not limited to CONSULTANT's subcontractors and subconsultants) possess all licenses, permits, certificates, qualifications and approvals of whatever nature that are legally required to perform the tasks and services contemplated under this Agreement and all such licenses, permits, certificates, qualifications and approvals shall be maintained throughout the term of this Agreement.

The Parties acknowledge and agree that CONSULTANT shall perform, at CONSULTANT's own cost and expense and without any reimbursement from CITY, any services necessary to correct any errors or omissions caused by CONSULTANT's failure to comply with the standard of care set forth under this Section or by any like failure on the part of CONSULTANT's employees, agents, contractors, subcontractors and subconsultants. Such effort by CONSULTANT to correct any errors or omissions shall be commenced immediately upon their discovery by either Party and shall be completed within seven (7) calendar days from the date of discovery or such other extended period of time authorized by the CITY Representatives in writing and absolute discretion. The Parties acknowledge and agree that CITY's acceptance of any work performed by CONSULTANT or on CONSULTANT's behalf shall not constitute a release of any deficiency or delay in performance. The Parties further acknowledge, understand and agree that CITY has relied upon the foregoing representations of CONSULTANT, including but not limited to the representation that CONSULTANT possesses the skills, training, knowledge and experience necessary to perform the Work in a skillful and competent manner equivalent to, the standard of performance generally recognized as being employed by professionals performing the same type of work and services in the State of California.

- 2.5 ASSIGNMENT: The skills, training, knowledge and experience of CONSULTANT are material to CITY's willingness to enter into this Agreement. Accordingly, CITY has an interest in the qualifications and capabilities of the person(s) who will perform the services and tasks to be undertaken by CONSULTANT or on behalf of CONSULTANT in the performance of this Agreement. In recognition of this interest, CONSULTANT agrees that it shall not assign or transfer, either directly or indirectly or by operation of law, this Agreement or the performance of any of CONSULTANT's duties or obligations under this Agreement without the prior written consent of the CITY. In the absence of CITY's prior written consent, any attempted assignment or transfer shall be ineffective, null and void and shall constitute a material breach of this Agreement.
- 2.6 CONTROL AND PAYMENT OF SUBORDINATES: The Work shall be performed by CONSULTANT or under CONSULTANT's strict supervision. CONSULTANT will determine the means, methods and details of performing the Work subject to the requirements of this Agreement. CITY retains CONSULTANT on an independent contractor basis and not as an employee. CONSULTANT reserves the right to perform similar or different services for others during the term of this Agreement, provided such work does not unduly interfere with CONSULTANT's competent performance under this Agreement or result in the unauthorized disclosure of CITY's confidential or proprietary information. Any additional personnel performing the Work under this Agreement on behalf of CONSULTANT are not employees of CITY and shall at all times be under CONSULTANT's exclusive direction and control. CONSULTANT shall pay all wages, salaries and other amounts due such personnel and shall assume responsibility for all benefits, payroll taxes, social security and Medicare payments and the like. CONSULTANT shall be responsible for all reports and obligations respecting such additional personnel, including, but not limited to: social security taxes, income tax withholding, unemployment insurance, disability insurance, workers' compensation insurance and the like.
- 2.7 REMOVAL OF EMPLOYEE OR AGENTS: If any of CONSULTANT's officers, employees, agents, contractors, subcontractors or subconsultants is determined by the CITY Representatives to be uncooperative, incompetent, a threat to the adequate or timely performance of the tasks assigned to CONSULTANT, a threat to persons or property, or if any of CONSULTANT's officers, employees, agents, contractors, subcontractors or subconsultants fail or refuse to perform the work in a manner acceptable to the CITY such officer, employee, agent, contractor, subcontractor or subconsultant shall be promptly removed by CONSULTANT and shall not be re-assigned to perform any of the work.
- 2.8 COMPLIANCE WITH LAWS: CONSULTANT shall keep itself fully informed of and in compliance with all applicable laws, statutes, codes, rules, regulations and ordinances of the federal government of the United States of America, the State of California, the County of Los Angeles, and any other local governmental entity to the extent such laws, statutes, codes, rules, regulations or ordinances governing or affecting the performance of the Work.
- 2.9 SAFETY: CONSULTANT shall perform its work so as to avoid injury or damage to any person or property. In performing the Work, CONSULTANT shall at all times be in compliance with all applicable local, state and federal laws, rules and regulations, and shall exercise all necessary precautions for the safety of employees appropriate to the nature of the Work and the conditions under which any work is to be performed.
- 2.10. NON-DISCRIMINATION: In the performance of this Agreement, CONSULTANT shall not discriminate against any employee, subcontractor, subconsultant, or applicant for employment because of race, color, creed, religion, sex, marital status, sexual orientation, national origin, ancestry, age, physical or mental disability or medical condition.
- 2.11. INDEPENDENT CONTRACTOR: The Parties acknowledge, understand and agree that CONSULTANT and all persons retained or employed by CONSULTANT are, and shall at all times remain, wholly independent contractors and are not officials, officers, employees, departments or subdivisions of CITY. CONSULTANT shall be solely responsible for the supervision of its employees,

agents, contractors, subcontractors and subconsultants and for the negligent acts and/or omissions of the same. All persons retained or employed by CONSULTANT shall have no authority, express or implied, to bind CITY in any manner, nor to incur any obligation, debt or liability of any kind on behalf of, or against, CITY, whether by contract or otherwise, unless such authority is expressly conferred to CONSULTANT under this Agreement or is otherwise expressly conferred by CITY in writing.

III. INSURANCE

- 3.1 DUTY TO PROCURE AND MAINTAIN INSURANCE: As more specifically set forth below under this Article, CONSULTANT agrees that it shall procure and maintain throughout the Initial Term of this Agreement and any extension term (or for such extended period of time as may be required under this Article) insurance against claims for death or injuries to persons or damages to property that may arise from or in connection with CONSULTANT's performance of this Agreement. CONSULTANT shall also procure and maintain such other types of insurance as may be required under this Article, below. CITY shall not, and shall be under no obligation to, issue a Notice to Proceed until CONSULTANT has provided evidence satisfactory to CITY that it has procured all insurance required under this Article.
- 3.2 REQUIRED COVERAGES: CONSULTANT agrees that it shall procure and maintain the following insurance coverage, at its own expense, for the duration for this Agreement or any extended period set forth herein:
- A. Commercial General Liability Insurance: CONSULTANT shall procure and maintain Commercial General Liability Insurance ("CGL Coverage") as broad as Insurance Services Office Commercial General Liability coverage (occurrence Form CG 0001 or equivalent). Such CGL Coverage shall have minimum limits of no less than One Million Dollars (\$1,000,000.00) per occurrence for bodily injury, personal injury, property damage, operations, products and completed operations, and contractual liability and Two Million Dollars (\$2,000,000.00) in the aggregate.
 - B. Automobile Liability Insurance: CONSULTANT shall procure and maintain Automobile Liability Insurance as broad as Insurance Services Office Form Number CA 0001 covering Automobile Liability, Code 1 (any auto). Such Automobile Liability Insurance shall have minimum limits of no less than One Million Dollars (\$1,000,000.00) per accident for bodily injury and property damage.
 - C. Workers' Compensation Insurance/ Employer's Liability Insurance: CONSULTANT shall procure and maintain Workers' Compensation Insurance affording coverage at least as broad as that required by the State of California with Employer's Liability Insurance with minimum limits of no less than One Million Dollars (\$1,000,000.00) per accident for bodily injury or disease. The Workers' Compensation insurer shall also agree to waive all rights of subrogation against CITY, the City Council and CITY's elected and appointed officials, officers, employees, agents and volunteers for losses paid under the terms of the insurance policy.
 - D. Professional Liability Insurance: For the full term of this Agreement and for a period of three (3) years thereafter, CONSULTANT shall procure and maintain Errors and Omissions Liability Insurance appropriate to CONSULTANT's profession. Such coverage shall have minimum limits of no less than One Million Dollars (\$1,000,000.00) per claim and shall be endorsed to include contractual liability.
- 3.3 ADDITIONAL INSURED REQUIREMENTS: The CGL Coverage and the Automobile Liability Insurance shall contain an endorsement naming the CITY, the City Council and CITY's elected and appointed officials, officers, employees, agents and volunteers as additional insureds.
- 3.4 REQUIRED CARRIER RATING: All varieties of insurance required under this Agreement shall be procured from insurers licensed in the State of California and authorized to issue policies directly to

California insureds. Except as otherwise provided elsewhere under this Article, all required insurance shall be procured from insurers, who according to the latest edition of the Best's Insurance Guide have an A.M. Best's rating of no less than A:VII. CITY may also accept policies procured by insurance carriers with a Standard & Poor's rating of no less than BBB according to the latest published edition the Standard & Poor's rating guide. As to Workers' Compensation Insurance/ Employer's Liability Insurance, the CITY Representatives are authorized to authorize lower ratings than those set forth in this Section.

- 3.5 PRIMACY OF CONSULTANT'S INSURANCE: All policies of insurance provided by CONSULTANT shall be primary to any coverage available to CITY, the City Council and CITY's elected and appointed officials, officers, employees, agents and volunteers. Any insurance or self-insurance maintained by CITY, the City Council and CITY's elected and appointed officials, officers, employees, agents and volunteers shall be in excess of CONSULTANT's insurance and shall not contribute with it.
- 3.6 WAIVER OF SUBROGATION: All insurance coverage provided pursuant to this Agreement shall not prohibit CONSULTANT or CONSULTANT's officers, employees, agents, subcontractors or subconsultants from waiving the right of subrogation prior to a loss. CONSULTANT hereby waives all rights of subrogation against CITY.
- 3.7 VERIFICATION OF COVERAGE: CONSULTANT acknowledges, understands and agrees that CITY's ability to verify the procurement and maintenance of the insurance required under this Article is critical to safeguarding the CITY's financial well-being. Accordingly, CONSULTANT warrants, represents and agrees that it shall furnish CITY with original certificates of insurance and endorsements evidencing the coverage required under this Article on forms satisfactory to CITY in its sole and absolute discretion. **The certificates of insurance and endorsements for each insurance policy shall be signed by a person authorized by that insurer to bind coverage on its behalf, and shall be on forms provided by the CITY if requested.** All certificates of insurance and endorsements shall be received and approved by CITY as a condition precedent to CONSULTANT's commencement of any work or any of the Work. Upon CITY's written request, CONSULTANT shall also provide CITY with certified copies of all required insurance policies as a condition precedent to the commencement of any work or any of the Work. CITY shall not, and shall be under no obligation to, issue a Notice to Proceed until CONSULTANT fully complies with this Section. The requirements of this Section cannot be waived and any attempted waiver shall be void, invalid and non-binding upon CITY.
- 3.8 FAILURE TO ADHERE TO INSURANCE PROVISIONS: In addition to any other remedies CITY may have under this Agreement or at law or in equity, if CONSULTANT fails to comply with any of the requirements set forth in this Article, CITY may, but shall not be obligated to: (i) Order CONSULTANT to stop any and all work under this Agreement or withhold any payment, which becomes due to CONSULTANT hereunder, or both stop work and withhold any payment, until CONSULTANT demonstrates compliance with the requirements hereof; or (ii) terminate this Agreement. CITY's exercise of any of the foregoing remedies, shall be in addition to any other remedies CITY may have and is not the exclusive remedy for CONSULTANT's failure to comply with the insurance requirements set forth under this Article.
- 3.9 SUBCONTRACTORS INSURANCE COVERAGE: CONSULTANT shall include all persons and entities performing work on its behalf as insureds (including all contractors, subcontractors and subconsultants) or, in the alternative, shall furnish separate certificates of insurance and endorsements for each such persons or entities evidencing their independent procurement of insurance. All coverages for such persons or entities shall be identical to the requirements imposed upon CONSULTANT under this Article.
- 3.10 NO LIMITATION ON LIABILITY: CONSULTANT's procurement of insurance shall not be construed as a limitation of CONSULTANT's liability or as full performance of CONSULTANT's indemnification duties set forth under Article V of this Agreement.

IV.
INDEMNIFICATION

4.1 The Parties agree that City and City's engineer, elected and appointed officials, officers, employees, agents and volunteers (hereinafter, the "City Indemnitees") should, to the fullest extent permitted by law, be protected from any and all loss, injury, damage, claim, lawsuit, cost, attorneys' fees, litigation costs, or any other cost arising out of or in any way related to the performance of this Agreement. Accordingly, the provisions of this indemnity provision are intended by the Parties to be interpreted and construed to provide the City Indemnitees with the fullest protection possible under the law. Consultant acknowledges that City would not enter into this Agreement in the absence of Consultant's commitment to indemnify, defend and protect the City as set forth herein.

4.2 To the fullest extent permitted by law, the Consultant shall (i) immediately defend and (ii) indemnify and hold harmless the City and its engineer, elected and appointed officials, officers, agents, employees, attorneys, servants, volunteers, successors and assigns from and against any and all liabilities, regardless of nature or type that arise out of, pertain to, or relate to the negligence, recklessness, or willful misconduct of the Consultant, or its officers, employees, servants, agents, subcontractors, volunteers or any other person or entity involved by, for, with or on behalf of Consultant in the performance of this Agreement. The parties understand and agree that the duty of Consultant to indemnify and hold harmless includes the duty to defend as set forth in Section 2778 of the California Civil Code. Liabilities subject to the duties to defend and indemnify include, without limitation, all claims, losses, damages, penalties, fines, and judgments; associated investigation and administrative expenses; defense costs, including but not limited to reasonable attorneys' fees incurred by legal counsel of City's choosing; court costs; and costs of alternative dispute resolution. The Consultant's obligation to indemnify applies unless it is finally adjudicated that the liability was caused by the sole active negligence or sole willful misconduct of an indemnified party. If it is finally adjudicated that liability is caused by the comparative active negligence or willful misconduct of an indemnified party, then Consultant's indemnification obligation shall be reduced in proportion to the established comparative liability.

4.3 The duty to defend is a separate and distinct obligation from Consultant's duty to indemnify. Consultant shall be obligated to defend, in all legal, equitable, administrative, or special proceedings, with counsel approved by the City, City and its engineer, elected and appointed officials, officers, agents, employees, attorneys, servants, volunteers, successors and assigns, immediately upon tender to City of the claim in any form or at any stage of an action or proceeding, whether or not liability is established. An allegation or determination that persons other than Consultant are responsible for the claim does not relieve Consultant from its separate and distinct obligation to defend under this section. The obligation to defend extends through final judgment, including exhaustion of any appeals. The defense obligation includes an obligation to provide independent defense counsel if Consultant asserts that liability is caused in whole or in part by the negligence or willful misconduct of the indemnified party. If it is finally adjudicated that liability was caused by the comparative active negligence or willful misconduct of an indemnified party, Consultant may submit a claim to the City for reimbursement of reasonable attorneys' fees and defense costs in proportion to the established comparative liability of the indemnified party.

4.4 City shall have the right to offset against the amount of any compensation due Consultant under this Agreement any amount due City from Consultant as a result of Consultant's failure to pay City promptly any indemnification arising under this Article and related to Consultant's failure to either (i) pay taxes on amounts received pursuant to this Agreement or (ii) comply with applicable workers' compensation laws.

4.5 The obligations of Consultant under this Article will not be limited by the provisions of any workers' compensation act or similar act. Consultant expressly waives its statutory immunity under such statutes or laws as to City and City's engineer, elected and appointed officials, officers, employees, agents and volunteers.

4.6 Consultant agrees to obtain executed indemnity agreements with provisions identical to those set forth here in this Article from each and every subcontractor or any other person or entity involved by, for, with or on behalf of Consultant in the performance of this Agreement. In the event Consultant fails to obtain such indemnity obligations from others as required herein, Consultant agrees to be fully responsible and indemnify, hold harmless and defend City and City's engineer, elected and appointed officials, officers, employees, agents and volunteers from and against any and all claims and losses, costs or expenses for any damage due to death or injury to any person and injury to any property resulting from any alleged intentional, reckless, negligent, or otherwise wrongful acts, errors or omissions of Consultant's subcontractors or any other person or entity involved by, for, with or on behalf of Consultant in the performance of this Agreement. Such costs and expenses shall include reasonable attorneys' fees incurred by counsel of City's choice.

4.7 The City does not, and shall not, waive any rights that it may possess against Consultant because of the acceptance by the City, or the deposit with the City, of any insurance policy or certificate required pursuant to this Agreement. This hold harmless and indemnification provision shall apply regardless of whether or not any insurance policies are determined to be applicable to the claim, demand, damage, liability, loss, cost or expense.

4.8 This Article and all provisions contained herein (including but not limited to the duty to indemnify, defend and hold free and harmless) shall survive the termination or normal expiration of this Agreement and is in addition to any other rights or remedies which the City may have at law or in equity.

V. TERMINATION

5.1 TERMINATION WITHOUT CAUSE: CITY may terminate this Agreement at any time for convenience and without cause by giving written notice to CONSULTANT at least five (5) calendar days prior to the effective date of such termination for convenience. Upon termination for convenience, CONSULTANT shall be compensated only for the Work which has been adequately rendered to CITY up to the effective date of the termination, and CONSULTANT shall be entitled to no further compensation. CONSULTANT may not terminate this Agreement except for breach of this Agreement. If this Agreement is terminated as provided herein, CITY may require CONSULTANT to provide all finished or unfinished Documents and Data, as defined in Section 7.1 below, and other information of any kind prepared by CONSULTANT in connection with the performance of the Work. CONSULTANT shall be required to provide such documents and other information within fifteen (15) calendar days of the request. In the event this Agreement is terminated in whole or in part as provided herein, CITY may procure, upon such terms and in such manner as it may determine appropriate, Work similar to those terminated.

5.2 DEFAULT, BREACH AND TERMINATION IN THE EVENT OF BREACH: In the event either Party fails to perform, or adhere to, any applicable duty, obligation or standard of conduct set forth under this Agreement (or fails to perform or adhere to any such duty, obligation or standard of conduct at the time, place or manner set forth in this Agreement), an event of default (hereinafter, "Event of Default") shall have occurred. Except as otherwise provided in this Agreement, if an Event of Default remains uncured by the defaulting Party for a period in excess of fourteen (14) calendar days from the date upon which the non-defaulting Party issues notice of default (hereinafter, a "Default Notice") to the defaulting Party, then the default shall constitute a breach of this Agreement. If a Party is in breach of this Agreement, the non-breaching Party may pursue any and all remedies available to it at law or in equity. If CONSULTANT is in breach (whether or not such breach is caused by CONSULTANT or CONSULTANT's officials, officers, employees, agents, contractors, subcontractors or subconsultants, CITY may, in its sole and absolute discretion (and without obligation), terminate this Agreement immediately upon the issuance written notice of termination on the grounds of breach (a "Breach-Termination Notice") which notice shall specify the effective date of such termination for cause. CITY's ability to terminate this Agreement as provided in this Section shall be in addition to any other remedies CITY may have at law or in equity in the event of breach and shall not be in lieu of such other remedies.

- 5.3 SCOPE OF WAIVER: No waiver of any default or breach under this Agreement shall constitute a waiver of any other default or breach, whether of the same or other covenant, warranty, agreement, term, condition, duty or requirement contained in this Agreement. No waiver, benefit, privilege, or service voluntarily given or performed by a Party shall give the other Party any contractual rights by custom, estoppel, or otherwise.
- 5.4 SURVIVING ARTICLES, SECTIONS AND PROVISIONS: The termination of this Agreement pursuant to any provision of this Article or by normal expiration of its term or any extension thereto shall not operate to terminate any Article, Section or provision contained herein which provides that it shall survive the termination or normal expiration of this Agreement.

VI.
MISCELLANEOUS PROVISIONS

- 6.1 DOCUMENTS & DATA; LICENSING OF INTELLECTUAL PROPERTY: All Documents and Data shall be and remain the property of CITY without restriction or limitation upon their use or dissemination by CITY. For purposes of this Agreement, the term "Documents and Data" means and includes all reports, studies, analyses, correspondence, plans, drawings, designs, renderings, specifications, notes, summaries, strategies, charts, schedules, spreadsheets, calculations, lists, data compilations, documents or other materials developed and/or assembled by or on behalf of CONSULTANT in the performance of this Agreement and fixed in any tangible medium of expression, including but not limited to Documents and Data stored on paper, digitally, magnetically and/or electronically. CONSULTANT shall require all subcontractors and subconsultants working on behalf of CONSULTANT in the performance of this Agreement to agree in writing that CITY shall be granted the same right to copy, use, reuse, disseminate and retain Documents and Data prepared or assembled by any subcontractor or subconsultant as applies to Documents and Data prepared by CONSULTANT in the performance of this Agreement.
- 6.2 CONFIDENTIALITY: All ideas, memoranda, specifications, plans, procedures, drawings, descriptions, computer program data, input recorded data, written information, and other like information either created by or provided to CONSULTANT in connection with the performance of this Agreement shall be held confidentially by CONSULTANT. Such materials shall not, without the prior written consent of CITY, be used by CONSULTANT for any purposes other than the performance of the Work. Nor shall such materials be disclosed to any person or entity not connected with the performance of the Work. Nothing furnished to CONSULTANT which is otherwise known to CONSULTANT or is generally known, or has become known, to the related industry shall be deemed confidential. CONSULTANT shall not use CITY's name or insignia, photographs, or any publicity pertaining to the Work in any magazine, trade paper, newspaper, television or radio production or other similar medium without the prior written consent of CITY.
- 6.3 NOTICES: All notices permitted or required under this Agreement shall be given to the respective Parties at the following addresses, or at such other address as the respective Parties may provide in writing for this purpose:

CONSULTANT:

[Name, Address, Phone, Fax, and other relevant contact information for Consultant]

CITY:

City of San Fernando
Attn: Deputy City Manager
117 Macneil Street
San Fernando, CA 91340
Tel: (818) 898-1222

Such notices shall be deemed effective when (i) personally delivered; (ii) successfully transmitted by facsimile as evidenced by a fax confirmation slip; (iii) when successfully transmitted and received via electronic mail at any of the e-mail addresses listed above; or (iv) when mailed, forty-eight (48) hours

after deposit with the United States Postal Service, first class postage prepared and addressed to the Party at its applicable address.

- 6.4 COOPERATION; FURTHER ACTS: The Parties shall fully cooperate with one another, and shall take any additional acts or sign any additional documents as is reasonably necessary, appropriate or convenient to achieve the purposes of this Agreement.
- 6.5 SUBCONTRACTING: CONSULTANT shall not subcontract any portion of the Work required by this Agreement, except as expressly stated herein, without the prior written approval of CITY. Subcontracts (including without limitation subcontracts with subconsultants), if any, shall contain a provision making them subject to all provisions stipulated in this Agreement, including provisions relating to insurance requirements and indemnification.
- 6.6 CITY'S RIGHT TO EMPLOY OTHER CONSULTANTS: CITY reserves the right to employ other consultants in connection with the various projects worked upon by CONSULTANT.
- 6.7 PROHIBITED INTERESTS: CONSULTANT warrants, represents and maintains that it has not employed nor retained any company or person, other than a *bona fide* employee working solely for CONSULTANT, to solicit or secure this Agreement. Further, CONSULTANT warrants and represents that it has not paid nor has it agreed to pay any company or person, other than a *bona fide* employee working solely for CONSULTANT, any fee, commission, percentage, brokerage fee, gift or other consideration contingent upon or resulting from the award or making of this Agreement. For breach or violation of this warranty, CITY shall have the right to rescind this Agreement without liability. For the term of this Agreement, no member, officer or employee of CITY, during the term of his or her service with CITY, shall have any direct interest in this Agreement, or obtain any present or anticipated material benefit arising therefrom.
- 6.8 TIME IS OF THE ESSENCE: Time is of the essence for each and every provision of this Agreement.
- 6.9 FORCE MAJEURE: Any prevention, delay, nonperformance or stoppage due to any of the following causes shall excuse nonperformance for a period equal to such obligations imposed by this Agreement. The causes referred to above are strikes, walkouts, labor disputes, failure of power, irresistible superhuman cause, acts of public enemies of the State or United States, riots, insurrections, civil commotion, inability to obtain labor or material or reasonable substitutes for either, governmental restrictions or regulations or controls (except those reasonably foreseeable in connection with the uses contemplated by this Agreement), casualties not contemplated by insurance provisions of this agreement, or other causes beyond the reasonable control of the party obligated to perform.
- 6.10 GOVERNING LAW; VENUE: This Agreement shall be interpreted and governed according to the laws of the State of California. In the event of litigation between the Parties, venue, without exception, shall be in the Los Angeles County Superior Court of the State of California. If, and only if, applicable law requires that all or part of any such litigation be tried exclusively in federal court, venue, without exception, shall be in the Central District of California located in the City of Los Angeles, California.
- 6.11 ATTORNEY'S FEES: If either Party commences an action against the other Party, either legal, administrative or otherwise, arising out of or in connection with this Agreement, the prevailing Party in such litigation shall be entitled to have and recover from the losing Party reasonable attorney's fees and all other costs of such action.
- 6.12 SUCCESSORS AND ASSIGNS: This Agreement shall be binding on the successors and assigns of the Parties.

- 6.13 NO THIRD PARTY BENEFIT: There are no intended third party beneficiaries of any right or obligation assumed by the Parties. All rights and benefits under this Agreement inure exclusively to the Parties.
- 6.14 CONSTRUCTION OF AGREEMENT: This Agreement shall not be construed in favor of, or against, either Party but shall be construed as if the Parties prepared this Agreement together through a process of negotiation and with the advice of their respective attorneys.
- 6.15 SEVERABILITY: If any portion of this Agreement is declared invalid, illegal, or otherwise unenforceable by a court of competent jurisdiction, the remaining provisions shall continue in full force and effect.
- 6.16 AMENDMENT; MODIFICATION: No amendment, modification or supplement of this Agreement shall be valid or binding unless executed in writing and signed by both Parties, subject to CITY approval. The requirement for written amendments, modifications or supplements cannot be waived and any attempted waiver shall be void and invalid.
- 6.17 CAPTIONS: The captions of the various articles, sections and paragraphs are for convenience and ease of reference only, and do not define, limits, augment, or describe the scope, content, or intent of this Agreement.
- 6.18 INCONSISTENCIES OR CONFLICTS: In the event of any conflict or inconsistency between the provisions of this Agreement and any of the exhibits attached hereto, the provisions of this Agreement shall control.
- 6.19 ENTIRE AGREEMENT: This Agreement including all attached exhibits is the entire, complete, final and exclusive expression of the Parties with respect to the matters addressed herein and supersedes all other agreements or understandings, whether oral or written, or entered into between CITY and CONSULTANT prior to the execution of this Agreement. No statements, representations or other agreements, whether oral or written, made by any Party which are not embodied herein shall be valid or binding. No amendment, modification or supplement to this Agreement shall be valid and binding unless in writing and duly executed by the Parties pursuant to Section 6.16, above.
- 6.20 COUNTERPARTS: This Agreement shall be executed in two (2) original counterparts each of which shall be of equal force and effect. One counterpart shall be delivered to CONSULTANT and the other shall be retained by CITY. No handwritten or typewritten amendment, modification or supplement to any one counterparts shall be valid or binding unless made to all three counterparts in conformity with Section 6.16, above.

[SIGNATURE PAGE TO FOLLOW]

AS OF THE DATE FIRST WRITTEN ABOVE, the Parties evidence their agreement to the terms of this Agreement by signing below:

CITY:
City of San Fernando

By: _____

Name: _____

Title: _____

APPROVED AS TO FORM:

By: _____
City Attorney

CONSULTANT:
Comfort Systems USA

By: _____

Print: _____

Title: _____

DRAFT

**EXHIBIT "A"
[SCOPE OF WORK]**

DRAFT

THE
PURCHASING ASSOCIATION OF
COOPERATIVE ENTITIES (PACE)

Acknowledges

City of San Fernando

as a

VALUED MEMBER

www.pacecoop.org

PACE

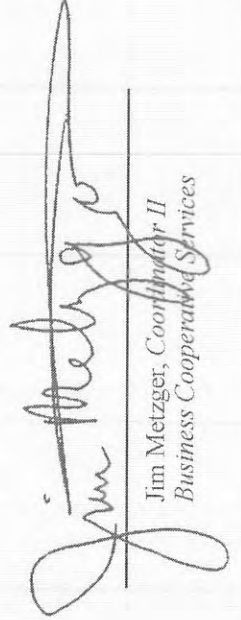

Jim Metzger, Coordinator II
Business Cooperative Services



Purchasing Association of Cooperative Entities

Contracts

Vendor	Commodity/Service	Contract	HUB
ABM	Building Cleaning Services	P00151	
Acoustical Solutions	Soundproofing and Noise Control	P00131	
AHI Enterprises	Office Supplies, Furniture	P00106	Yes
AHI-Facilities	Janitorial and Sanitation Supplies	P00155	
AHI Industrial, LLC	Industrial Supplies	P00128	
Amazon	On-Line Retailer	P00107	
AMX Schoolview	PA & AV Intregation Systems	P00134	
Armstrong Mechanical Co.	Building Repair & Maintenance	P00163	
Belfor USA Group	Disaster Recovery and Repair	P00159	
Cascio Interstate Music	Musical Instruments and Supplies and Accessories	P00127	
CASO Document Management	Enterprise Content Management	P00147	
CenterLine Supply	Traffic Products and Warning Signs	P00138	
Clear Visions, Inc.	Printing Services	P00133	
Dahill Office Technology Corporation	Copier Supplies, Equipment and Connectivity	P00161	
Domtar/Bosworth Papers	Fine Paper Products	P00148	Yes
Dealers Electrical Supply	Electrical Supplies	P00156	
ECOLAB	Chemical	P00123	
FBS - Financial Benefit Services	Employee Benefit Administration	P00146	
Flynn Southwest LP	Roofing	P00155	
Galls	Public Safety Equipment and Apparel	P00108	
Global Gov/Ed Solutions	On-Line Retailer	P00162	
Gunn Nissan	Fleet Vehicles	P00164	
Lennox Industries	Heating, Ventilation & Air/Conditioning	P00143	
LivingTree	Multi-Tiered Private collaboration Network	P00140	
McLemore Building Maintenance	Building Cleaning Services	P00151	
McLemore Building Maintenance	Landscaping Services	P00152	
MD Live/Financial Benefit Services	Professional Telehealth Management Services	P00160	
Moore Medical	First Aid & Safety	P00139	
M Tech, Inc.: Comfort Systems USA	Building Repair & Maintenance	P00116B	
Parsons Roofing	Roofing	P00155	
Republic Services Inc.	Waste Collections	P00153	

SHI Government Solutions	Electronic Computing Products	P00132	Yes
Summit Integration Systems	Audio, Visual	P00130	
TD Industries	Building Repair & Maintenance	P00116	
TigerDirect	On-Line Retailer	P00162	
TriTechnologies, LTD	Asphalt Rejuvenator	P00138	

© Copyright 2013 | Education Service Centers, Regions 13 and 20 | All Rights Reserved
Contact the [Webmaster](#) for assistance with this site | [Terms of Use/Privacy Policy](#)

powered by [ezTask](#)™

*This Page
Intentionally
Left Blank*



AGENDA REPORT

To: Mayor Joel Fajardo and Councilmembers

From: Brian Saeki, City Manager
By: Chris Marcarello, Deputy City Manager

Date: December 7, 2015

Subject: Consideration to Adopt Resolutions Pertaining to the Addition of Property Assessed Clean Energy (PACE) Financing Program Provider to City PACE Program

RECOMMENDATION:

It is recommended that the City Council:

- a. Adopt Resolution Nos. 7719 and 7720, approving membership in the California Home Finance Authority (CHF) and consenting to the inclusion of properties within the City to participate in CHF Community Facilities District No. 2014-1, which will enable property owners to finance permanently fixed renewable energy and water efficiency improvements, and electric vehicle charging infrastructure on their properties; and
- b. Authorize the City Manager to execute any related agreement or documents to facilitate participation in the CHF Property Assessed Clean Energy (PACE) financing programs, which will allow local property owners to participate in this PACE Program.

BACKGROUND:

Through the California HERO Program, the City currently participates in a "Property-Assessed Clean Energy" (PACE) program which helps property owners finance energy efficiency improvements. PACE Programs are a form of financing that creates municipal finance districts to provide loans to homeowners and businesses for energy-efficient retrofits and renewable energy system installations. Loans are repaid through an annual surcharge on property tax assessments. As of the end of October 2015, 20 projects have been completed in the City with a value of nearly \$500,000. It is estimated that these projects have saved approximately 2.5 million kilowatt hours of electricity, reduced 733 tons of carbon emissions and helped to save over 1.1 million gallons of water.

The City was recently approached by an additional PACE program provider for possible participation in its program. This PACE program is provided under the California Home Financing Authority (CHF) and is administered by the Ygrene Energy Fund LLC (Ygrene).

Consideration to Adopt Resolutions Pertaining to the Addition of Property Assessed Cleaned Energy (PACE) Financing Program Provider to City PACE ProgramPage 2 of 5

Participation in the Ygrene program would offer the community an additional PACE financing program alternative for financing energy and water efficiency improvements.

ANALYSIS:

Both Assembly Bill (AB) 811 and AB 474 amended Chapter 29 of Part 3 of Division 7 of the California Streets and Highways Code (Chapter 29), authorizing local legislative bodies to designate an area within which authorized public officials and willing property owners may enter into voluntary contractual assessments to finance the installation of distributed renewable energy sources, energy efficiency, and/or water conservation improvements that are permanently fixed to real property.

In addition, Senate Bill (SB) 511 amended the Mello-Roos Community Facilities Act contained in Sections 53311 through 53368.3 of the California Government Code to allow for the creation of Community Facilities Districts (CFDs) for the purpose of financing or refinancing the acquisition, installation and improvement of energy efficiency, water conservation, renewable energy and electric vehicle charging infrastructure improvements permanently affixed to private or public-owned real property. Individual properties can be annexed into the district and be subject to the special tax that is imposed to repay project financing. Participation in this program is entirely voluntary for local property owners.

Under this legislation, several "Property-Assessed Clean Energy" (PACE) programs have been initiated to help property owners finance energy efficiency improvements. PACE Programs are a form of financing that creates municipal finance districts to provide loans to homeowners and businesses for energy-efficient retrofits and renewable energy system installations. Loans are repaid through an annual surcharge on property tax assessments. Through this financing program, two alternatives are available to help local property owners. Both entail the same programming options for property owners.

YGrene/California Home Finance Authority Program

The California Home Finance Authority (CHF) has established two Property-Assessed Clean Energy" (PACE) programs have been initiated to help property owners finance energy efficiency improvements. The CHF program is administered by Ygrene Energy Fund LLC. In order to participate in the program, public agencies need to adopt a resolution that authorizes City participation under the CHF SB 555 Community Facilities District program and a resolution that authorizes participation under the CHF AB 811 Authority PACE Program. Each resolution authorizes CHF to accept applications from interested property owners and to conduct necessary proceedings related to program financing, including levying taxes or contractual assessments.

Consideration to Adopt Resolutions Pertaining to the Addition of Property Assessed Cleaned Energy (PACE) Financing Program Provider to City PACE ProgramPage 3 of 5

Approval of these resolutions would authorize the City to become an Associate Member of the CHF through a Joint Powers Agreement (JPA) (Exhibit "A" of Attachment "A"). Further, this membership would allow residents to participate in CHF PACE programs to make energy and water efficiency improvements. This membership requires no financial commitment to the City.

The California Home Financing Authority/Ygrene Program is being offered to allow property owners in participating cities and counties to finance renewable energy, energy water efficiency improvements, and electric vehicle charging infrastructure on their property. If a property owner chooses to participate, related property improvements will be financed by the issuance of bonds by a joint powers authority, the California Home Financing Authority (CHF), and secured by a voluntary contractual assessment or tax levied on such owner's property. Participation in the program is 100% voluntary. Property owners wishing to participate in the program agree to repay monies through a voluntary contractual assessment collected together with their property taxes.

The application process for the CHF/Ygrene Program includes the following:

- Property owners apply either online or through a hard copy application.
- If approved, the resident will receive an email indicating the maximum approval amount and information about the next steps.
- Property owners work with a licensed contractor to determine what eligible products to install. The contractor will need to call a program representative to obtain approval for the use of products.
- Financing documents will be sent to residents. Once the documents are signed, notarized, and returned, the resident can begin installing eligible products.
- Once all eligible products are installed, the property owner will need to submit the signed completion certificate with all invoices, permits and other required attachments. After the completion certificate is reviewed and approved, program representatives issue payment to the selected contractor.

Program Benefits for Property Owners

- Voluntary Program to Generate Savings - A convenient alternative to finance energy efficiency improvements and lower utility bills. Further, the program is voluntary and property owners choose to participate at their discretion.

Consideration to Adopt Resolutions Pertaining to the Addition of Property Assessed Cleaned Energy (PACE) Financing Program Provider to City PACE ProgramPage 4 of 5

- Repayment – Under this program, a voluntary contractual assessment stays with the property upon transfer of ownership. Most private property-related loans are due upon the sale of the benefited property, sometimes making it difficult for property owners to match the life of the repayment obligation to the useful life of financed improvements. However, some mortgage providers may require that the assessment be paid off at the time a property is refinanced or sold.
- Prepayment Option – Property Owners may choose to pay off assessments at any time, subject to applicable prepayment penalties.

Program Benefits to the City

- Promotes Energy Efficiency – Provides access for property owners to increase efficiency and help promote sustainability.
- Increase Property Values – Energy efficiency improvements help to increase property values and related property tax revenue.
- No City Financial Obligation – The City is not obligated to repay the bonds or assessments levied on participating properties. Further, all related program administration is handled by the CHF/Ygrene Program, resulting in little, if any City resources to participate in the program.

The attached resolutions will authorize participation in the CHF/Ygrene Program for San Fernando property owners to finance renewable energy, energy efficiency, and water efficiency property improvements. The resolution will approve an amendment to the CHF Joint Powers Agreement to add the City as an Associate Member and allow local property owners to participate in this program.

BUDGET IMPACT:

There is no financial impact to the City for participation in this PACE Program.

CONCLUSION:

It is recommended that the City Council approve the attached resolution, authorizing participation in the CHF/Ygrene Program and providing the community with a voluntary financing mechanism for energy efficiency improvements.

Consideration to Adopt Resolutions Pertaining to the Addition of Property Assessed Cleaned Energy (PACE) Financing Program Provider to City PACE Program

Page 5 of 5

ATTACHMENTS:

- A. Resolution No. 7719
- B. Resolution No. 7720

ATTACHMENT "A"

RESOLUTION NO. 7719**RESOLUTION OF THE CITY COUNCIL OF THE CITY OF SAN FERNANDO, CALIFORNIA, CONSENTING TO INCLUSION OF PROPERTIES WITHIN THE CITY'S JURISDICTION IN THE CALIFORNIA HOME FINANCE AUTHORITY, PROGRAM TO FINANCE RENEWABLE ENERGY GENERATION, ENERGY AND WATER EFFICIENCY IMPROVEMENTS AND ELECTRIC VEHICLE CHARGING INFRASTRUCTURE AND APPROVING ASSOCIATE MEMBERSHIP IN THE JOINT EXERCISE OF POWERS AUTHORITY RELATED THERETO**

WHEREAS, the California Home Finance Authority ("Authority") is a joint exercise of powers authority established pursuant to Chapter 5 of Division 7, Title 1 of the Government Code of the State of California (Section 6500 and following) (the "Act") and the Joint Power Agreement entered into on July 1, 1993, as amended from time to time (the "Authority JPA"); and

WHEREAS, the Authority is in the process of amending the Authority JPA to formally change its name to the Golden State Finance Authority; and

WHEREAS, Authority has established a property-assessed clean energy ("PACE") Program (the "Authority PACE Program") to provide for the financing of renewable energy generation, energy and water efficiency improvements and electric vehicle charging infrastructure (the "Improvements") pursuant to Chapter 29 of the Improvement Bond Act of 1911, being Division 7 of the California Streets and Highways Code ("Chapter 29") within counties and cities throughout the State of California that elect to participate in such program; and

WHEREAS, City of San Fernando (the "City") is committed to development of renewable energy generation and energy and water efficiency improvements, reduction of greenhouse gases, and protection of the environment; and

WHEREAS, in Chapter 29, the Legislature has authorized cities and counties to assist property owners in financing the cost of installing Improvements through a voluntary contractual assessment program; and

WHEREAS, installation of such Improvements by property owners within the jurisdictional boundaries of the counties and cities that are participating in the Authority PACE Program would promote the purposes cited above; and

WHEREAS, the City wishes to provide innovative solutions to its property owners to achieve energy and water efficiency, and in doing so cooperate with Authority in order to efficiently and economically assist property owners within the City in financing such Improvements; and

WHEREAS, Authority has established the Authority PACE Program, which is such a voluntary contractual assessment program, as permitted by the Act, the Authority JPA, originally

made and entered into July 1, 1993, as amended to date, and the City, desires to become an Associate Member of the JPA by execution of the JPA Agreement, a copy of which is attached as Exhibit "A" hereto, to participate in the programs of the JPA and to assist property owners within the jurisdiction of the City in financing the cost of installing Improvements; and

WHEREAS, the City will not be responsible for the conduct of any assessment proceedings; the levy and collection of assessments or any required remedial action in the case of delinquencies in the payment of any assessments or the issuance, sale or administration of any bonds issued in connection with the Authority PACE Program.

NOW, THEREFORE, THE CITY COUNCIL OF THE CITY OF SAN FERNANDO DOES HEREBY RESOLVE, FIND, DETERMINE, AND ORDER AS FOLLOWS:

1. This City Council finds and declares that properties in the City's incorporated area will be benefited by the availability of the Authority PACE Program to finance the installation of the Improvements.

2. This City Council consents to inclusion in the Authority PACE Program of all of the properties in the jurisdictional boundaries of the City and to the Improvements, upon the request by and voluntary agreement of owners of such properties, in compliance with the laws, rules and regulations applicable to such program; and to the assumption of jurisdiction thereover by Authority for the purposes thereof.

3. The consent of this City Council constitutes assent to the assumption of jurisdiction by Authority for all purposes of the Authority PACE Program and authorizes Authority, upon satisfaction of the conditions imposed in this resolution, to take each and every step required for or suitable for financing the Improvements, including the levying, collecting and enforcement of the contractual assessments to finance the Improvements and the issuance and enforcement of bonds to represent such contractual assessments.

4. This City Council hereby approves joining the JPA as an Associate Member and authorizes the execution by appropriate City officials of any necessary documents to effectuate such membership.

5. City staff is authorized and directed to coordinate with Authority staff to facilitate operation of the Authority PACE Program within the City, and report back periodically to this City Council on the success of such program.

6. This Resolution shall take effect immediately upon its adoption. The City Clerk is directed to send a certified copy of this resolution to the Secretary of the Authority.

PASSED, APPROVED, AND ADOPTED this 7th day of December, 2015.

Joel Fajardo, Mayor

ATTEST:

Elena G. Chávez, City Clerk

STATE OF CALIFORNIA)
COUNTY OF LOS ANGELES) ss
CITY OF SAN FERNANDO)

I HEREBY CERTIFY that the foregoing Resolution was approved and adopted at a regular meeting of the City Council held on the 7th day of December, 2015, by the following vote to wit:

AYES:

NOES:

ABSENT:

Elena G. Chávez, City Clerk

Exhibit A

JPA Agreement

[to be inserted]

EXHIBIT "A"**CALIFORNIA HOME FINANCE AUTHORITY****AMENDED AND RESTATED JOINT EXERCISE OF POWERS AGREEMENT**

(Original date July 1, 1993 and as last amended and restated December 10, 2014)

THIS AMENDED AND RESTATED JOINT EXERCISE OF POWERS AGREEMENT ("Agreement") is entered into by and among the counties listed on Attachment 1 hereof and incorporated herein by reference. All such counties are referred to herein as "Members" with the respective powers, privileges and restrictions provided herein.

RECITALS

A. WHEREAS, the California Rural Home Mortgage Finance Authority ("CRHMFA") was created by a Joint Exercise of Powers Agreement dated July 1, 1993 pursuant to the Joint Exercise of Powers Act (commencing with Article 1 of Chapter 5 of Division 7 of Title 1 of the Government Code of the State of California (the "Act"). By Resolution 2003-02, adopted on January 15, 2003, the name of the authority was changed to CRHMFA Homebuyers Fund. The most recent amendment to the Joint Exercise of Powers Agreement was on January 28, 2004.

B. WHEREAS, the Members of CRHMFA Homebuyers Fund desire to update, reaffirm, clarify and revise certain provisions of the joint powers agreement, including the renaming of the joint powers authority, as set forth herein.

C. WHEREAS, the Members are each empowered by law to finance the construction, acquisition, improvement and rehabilitation of real property.

D. WHEREAS, by this Agreement, the Members desire to create and establish a joint powers authority to exercise their respective powers for the purpose of financing the construction, acquisition, improvement and rehabilitation of real property within the jurisdiction of the Authority as authorized by the Act.

NOW, THEREFORE, in consideration of the mutual covenants contained herein, the Members individually and collectively agree as follows:

1. Definitions

Unless the context otherwise requires, the following terms shall for purposes of this Agreement have the meanings specified below:

"Act" means the Joint Exercise of Powers Act, commencing with Article 1 of Chapter 5 of Division 7 of Title 1 of the Government Code of the State of California, including the Marks-Roos Local Bond Pooling Act of 1985, as amended.

"Agreement" means this Joint Exercise of Powers Agreement, as the same now exists or as it may from time to time be amended as provided herein.

"Associate Member" means a county, city or other public agency which is not a voting member of the Rural County Representatives of California, a California nonprofit corporation ("RCRC"), with legal power and authority similar to that of the Members, admitted pursuant to paragraph 4.d. below to associate membership herein by vote of the Board.

"Audit Committee" means a committee made up of the nine-member Executive Committee.

"Authority" means California Home Finance Authority ("CHF"), formerly known as CRHMFA Homebuyers Fund or California Rural Home Mortgage Finance Authority.

"Board" means the governing board of the Authority as described in Section 7 below.

"Bonds" means bonds, notes, warrants, leases, certificates of participation, installment purchase agreements, loan agreements and other securities or obligations issued by the Authority, or financing agreements entered into by the Authority pursuant to the Act and any other obligation within the meaning of the term "Bonds" under the Act.

"Delegate" means the Supervisor designated by the governing board of each Member to serve on the Board of the Authority.

"Executive Committee" means the nine-member Executive Committee of the Board established pursuant to Section 10 hereof.

"Member" means any county which is a member of RCRC, has executed this Agreement and has become a member of the Authority.

"Obligations" means bonds, notes, warrants, leases, certificates of participation, installment purchase agreements, loan agreements and other securities or obligations issued by the Authority, or financing agreements entered into by the Authority pursuant to the Act and any other financial or legal obligation of the Authority under the Act.

"Program" or "Project" means any work, improvement, program, project or service undertaken by the Authority.

"Rural County Representatives of California" or "RCRC" means the nonprofit entity incorporated under that name in the State of California.

"Supervisor" means an elected County Supervisor from an RCRC member county.

2. Purpose

The purpose of the Authority is to provide financing for the acquisition, construction, , improvement and rehabilitation of real property in accordance with applicable provisions of law for the benefit of residents and communities. In pursuit of this purpose, this Agreement provides for the joint exercise of powers common to any of its Members and Associate Members as provided herein, or otherwise authorized by the Act and other applicable laws, including assisting

in financing as authorized herein, jointly exercised in the manner set forth herein.

3. Principal Place of Business

The principal office of the Authority shall be 1215 K Street, Suite 1650, Sacramento, California 95814.

4. Creation of Authority; Addition of Members or Associate Members

a. The Authority is hereby created pursuant to the Act. As provided in the Act, the Authority shall be a public entity separate and distinct from the Members or Associate Members.

b. The Authority will cause a notice of this Agreement or any amendment hereto to be prepared and filed with the office of the Secretary of State of California in a timely fashion in the manner set forth in Section 6503.3 of the Act.

c. A county that is a member of RCRC may petition to become a member of the Authority by submitting to the Board a resolution or evidence of other formal action taken by its governing body adopting this Agreement. The Board shall review the petition for membership and shall vote to approve or disapprove the petition. If the petition is approved by a majority of the Board, such county shall immediately become a Member of the Authority.

d. An Associate Member may be added to the Authority upon the affirmative approval of its respective governing board and pursuant to action by the Authority Board upon such terms and conditions, and with such rights, privileges and responsibilities, as may be established from time to time by the Board. Such terms and conditions, and rights, privileges and responsibilities may vary among the Associate Members. Associate Members shall be entitled to participate in one or more programs of the Authority as determined by the Board, but shall not be voting members of the Board. The Executive Director of the Authority shall enforce the terms and conditions for prospective Associate Members to the Authority as provided by resolution of the Board and as amended from time to time by the Board. Changes in the terms and conditions for Associate Membership by the Board will not constitute an amendment of this Agreement.

5. Term and Termination of Powers

This Agreement shall become effective from the date hereof until the earlier of the time when all Bonds and any interest thereon shall have been paid in full, or provision for such payment shall have been made, or when the Authority shall no longer own or hold any interest in a public capital improvement or program. The Authority shall continue to exercise the powers herein conferred upon it until termination of this Agreement, except that if any Bonds are issued and delivered, in no event shall the exercise of the powers herein granted be terminated until all Bonds so issued and delivered and the interest thereon shall have been paid or provision for such payment shall have been made and any other debt incurred with respect to any other financing program established or administered by the Authority has been repaid in full and is no longer outstanding.

6. Powers; Restriction upon Exercise

a. To effectuate its purpose, the Authority shall have the power to exercise any and all powers of the Members or of a joint powers authority under the Act and other applicable provisions of law, subject, however, to the conditions and restrictions herein contained. Each Member or Associate Member may also separately exercise any and all such powers. The powers of the Authority are limited to those of a general law county.

b. The Authority may adopt, from time to time, such resolutions, guidelines, rules and regulations for the conduct of its meetings and the activities of the Authority as it deems necessary or desirable to accomplish its purpose.

c. The Authority shall have the power to finance the construction, acquisition, improvement and rehabilitation of real property, including the power to purchase, with the amounts received or to be received by it pursuant to a bond purchase agreement, bonds issued by any of its Members or Associate Members and other local agencies at public or negotiated sale, for the purpose set forth herein and in accordance with the Act. All or any part of such bonds so purchased may be held by the Authority or resold to public or private purchasers at public or negotiated sale. The Authority shall set any other terms and conditions of any purchase or sale contemplated herein as it deems necessary or convenient and in furtherance of the Act. The Authority may issue or cause to be issued Bonds or other indebtedness, and pledge any of its property or revenues as security to the extent permitted by resolution of the Board under any applicable provision of law. The Authority may issue Bonds in accordance with the Act in order to raise funds necessary to effectuate its purpose hereunder and may enter into agreements to secure such Bonds. The Authority may issue other forms of indebtedness authorized by the Act, and to secure such debt, to further such purpose. The Authority may utilize other forms of capital, including, but not limited to, the Authority's internal resources, capital markets and other forms of private capital investment authorized by the Act..

d. The Authority is hereby authorized to do all acts necessary for the exercise of its powers, including, but not limited to:

- (1) executing contracts,
- (2) employing agents, consultants and employees,
- (3) acquiring, constructing or providing for maintenance and operation of any building, work or improvement,
- (4) acquiring, holding or disposing of real or personal property wherever located, including property subject to mortgage,
- (5) incurring debts, liabilities or obligations,
- (6) receiving gifts, contributions and donations of property, funds, services and any other forms of assistance from persons, firms, corporations or governmental entities,
- (7) suing and being sued in its own name, and litigating or settling any suits or claims,
- (8) doing any and all things necessary or convenient to the exercise of its specific powers and to accomplishing its purpose
- (9) establishing and/or administering districts to finance and refinance the acquisition, installation and improvement of energy efficiency, water

conservation and renewable energy improvements to or on real property and in buildings. The Authority may enter into one or more agreements, including without limitation, participation agreements and implementation agreements to implement such programs.

e. Subject to the applicable provisions of any indenture or resolution providing for the investment of monies held thereunder, the Authority shall have the power to invest any of its funds as the Board deems advisable, in the same manner and upon the same conditions as local agencies pursuant to Section 53601 of the Government Code of the State of California.

f. All property, equipment, supplies, funds and records of the Authority shall be owned by the Authority, except as may be provided otherwise herein or by resolution of the Board.

g. Pursuant to the provisions of Section 6508.1 of the Act, the debts, liabilities and obligations of the Authority shall not be debts, liabilities and obligations of the Members or Associate Members. Any Bonds, together with any interest and premium thereon, shall not constitute debts, liabilities or obligations of any Member. The Members or Associate Members hereby agree that any such Bonds issued by the Authority shall not constitute general obligations of the Authority but shall be payable solely from the moneys pledged to the repayment of principal or interest on such Bonds under the terms of the resolution, indenture, trust, agreement or other instrument pursuant to which such Bonds are issued. Neither the Members or Associate Members nor the Authority shall be obligated to pay the principal of or premium, if any, or interest on the Bonds, or other costs incidental thereto, except from the revenues and funds pledged therefor, and neither the faith and credit nor the taxing power of the Members or Associate Members or the Authority shall be pledged to the payment of the principal of or premium, if any, or interest on the Bonds, nor shall the Members or Associate Members of the Authority be obligated in any manner to make any appropriation for such payment. No covenant or agreement contained in any Bond shall be deemed to be a covenant or agreement of any Delegate, or any officer, agent or employee of the Authority in an individual capacity, and neither the Board nor any officer thereof executing the Bonds or any document related thereto shall be liable personally on any Bond or be subject to any personal liability or accountability by reason of the issuance of any Bonds.

7. Governing Board

a. The Board shall consist of the number of Delegates equal to one representative from each Member.

b. The governing body of each Member shall appoint one of its Supervisors to serve as a Delegate on the Board. A Member's appointment of its Delegate shall be delivered in writing (which may be by electronic mail) to the Authority and shall be effective until he or she is replaced by such governing body or no longer a Supervisor; any vacancy shall be filled by the governing body of the Member in the same manner provided in this paragraph b..

c. The governing body of each Member of the Board shall appoint a Supervisor as an alternate to serve on the Board in the absence of the Delegate; the alternate may exercise all the

rights and privileges of the Delegate, including the right to be counted in constituting a quorum, to participate in the proceedings of the Board, and to vote upon any and all matters. No alternate may have more than one vote at any meeting of the Board, and any Member's designation of an alternate shall be delivered in writing (which may be by electronic mail) to the Authority and shall be effective until such alternate is replaced by his or her governing body or is no longer a Supervisor, unless otherwise specified in such appointment. Any vacancy shall be filled by the governing body of the Member in the same manner provided in this paragraph c..

d. Any person who is not a member of the governing body of a Member and who attends a meeting on behalf of such Member may not vote or be counted toward a quorum but may, at the discretion of the Chair, participate in open meetings he or she attends.

e. Each Associate Member may designate a non-voting representative to the Board who may not be counted toward a quorum but who may attend open meetings, propose agenda items and otherwise participate in Board Meetings.

f. Delegates shall not receive compensation for serving as Delegates, but may claim and receive reimbursement for expenses actually incurred in connection with such service pursuant to rules approved by the Board and subject to the availability of funds.

g. The Board shall have the power, by resolution, to the extent permitted by the Act or any other applicable law, to exercise any powers of the Authority and to delegate any of its functions to the Executive Committee or one or more Delegates, officers or agents of the Authority, and to cause any authorized Delegate, officer or agent to take any actions and execute any documents for and in the name and on behalf of the Board or the Authority.

h. The Board may establish such committees as it deems necessary for any lawful purpose; such committees are advisory only and may not act or purport to act on behalf of the Board or the Authority.

i. The Board shall develop, or cause to be developed, and review, modify as necessary, and adopt each Program.

8. Meetings of the Board

a. The Board shall meet at least once annually, but may meet more frequently upon call of any officer or as provided by resolution of the Board.

b. Meetings of the Board shall be called, noticed, held and conducted pursuant to the provisions of the Ralph M. Brown Act, Chapter 9 (commencing with Section 54950) of Part I of Division 2 of Title 5 of the Government Code of the State of California.

c. The Secretary of the Authority shall cause minutes of all meetings of the Board to be taken and distributed to each Member as soon as possible after each meeting.

d. The lesser of twelve (12) Delegates or a majority of the number of current Delegates shall constitute a quorum for transacting business at any meeting of the Board, except

that less than a quorum may act to adjourn a meeting. Each Delegate shall have one vote.

e. Meetings may be held at any location designated in notice properly given for a meeting and may be conducted by telephonic or similar means in any manner otherwise allowed by law.

9. Officers; Duties; Official Bonds

a. The Board shall elect a chair and vice chair from among the Delegates at the Board's annual meeting who shall serve a term of one (1) year or until their respective successor is elected. The chair shall conduct the meetings of the Board and perform such other duties as may be specified by resolution of the Board. The vice chair shall perform such duties in the absence or in the event of the unavailability of the chair.

b. The Board shall contract annually with RCRC to administer the Agreement and to provide administrative services to the Authority, and the President and Chief Executive Officer of RCRC shall serve *ex officio* as Executive Director, Secretary, Treasurer, and Auditor of the Authority. As chief executive of the Authority, the Executive Director is authorized to execute contracts and other obligations of the Authority, unless prior Board approval is required by a third party, by law or by Board specification, and to perform other duties specified by the Board. The Executive Director may appoint such other officers as may be required for the orderly conduct of the Authority's business and affairs who shall serve at the pleasure of the Executive Director. Subject to the applicable provisions of any indenture or resolution providing for a trustee or other fiscal agent, the Executive Director, as Treasurer, is designated as the custodian of the Authority's funds, from whatever source, and, as such, shall have the powers, duties and responsibilities specified in Section 6505.5 of the Act. The Executive Director, as Auditor, shall have the powers, duties and responsibilities specified in Section 6505.5 of the Act.

c. The Legislative Advocate for the Authority shall be the Rural County Representatives of California.

d. The Treasurer and Auditor are public officers who have charge of, handle, or have access to all property of the Authority, and a bond for such officer in the amount of at least one hundred thousand dollars (\$100,000.00) shall be obtained at the expense of the Authority and filed with the Executive Director. Such bond may secure the faithful performance of such officer's duties with respect to another public office if such bond in at least the same amount specifically mentions the office of the Authority as required herein. The Treasurer and Auditor shall cause periodic independent audits to be made of the Authority's books by a certified public accountant, or public accountant, in compliance with Section 6505 of the Act.

e. The business of the Authority shall be conducted under the supervision of the Executive Director by RCRC personnel.

10. Executive Committee of the Authority

a. Composition

The Authority shall appoint nine (9) members of its Board to serve on an Executive Committee.

b. Powers and Limitations

The Executive Committee shall act in an advisory capacity and make recommendations to the Authority Board. Duties will include, but not be limited to, review of the quarterly and annual budgets, service as the Audit Committee for the Authority, periodically review this Agreement; and complete any other tasks as may be assigned by the Board. The Executive Committee shall be subject to all limitations imposed by this Agreement, other applicable law, and resolutions of the Board.

c. Quorum

A majority of the Executive Committee shall constitute a quorum for transacting business of the Executive Committee.

11. Disposition of Assets

Upon termination of this Agreement, all remaining assets and liabilities of the Authority shall be distributed to the respective Members in such manner as shall be determined by the Board and in accordance with the law.

12. Agreement Not Exclusive; Operation in Jurisdiction of Member

This Agreement shall not be exclusive, and each Member expressly reserves its rights to carry out other public capital improvements and programs as provided for by law and to issue other obligations for those purposes. This Agreement shall not be deemed to amend or alter the terms of other agreements among the Members or Associate Members.

13. Conflict of Interest Code

The Authority shall by resolution adopt a Conflict of Interest Code as required by law.

14. Contributions and Advances

Contributions or advances of public funds and of personnel, equipment or property may be made to the Authority by any Member, Associate Member or any other public agency to further the purpose of this Agreement. Payment of public funds may be made to defray the cost of any contribution. Any advance may be made subject to repayment, and in that case shall be repaid in the manner agreed upon by the advancing Member, Associate Member or other public agency and the Authority at the time of making the advance.

15. Fiscal Year; Accounts; Reports; Annual Budget; Administrative Expenses

a. The fiscal year of the Authority shall be the period from January 1 of each year to and including the following December 31, except for any partial fiscal year resulting from a change

in accounting based on a different fiscal year previously.

b. Prior to the beginning of each fiscal year, the Board shall adopt a budget for the succeeding fiscal year.

c. The Authority shall establish and maintain such funds and accounts as may be required by generally accepted accounting principles. The books and records of the Authority are public records and shall be open to inspection at all reasonable times by each Member and its representatives.

d. The Auditor shall either make, or contract with a certified public accountant or public accountant to make, an annual audit of the accounts and records of the Authority. The minimum requirements of the audit shall be those prescribed by the State Controller for special districts under Section 26909 of the Government Code of the State of California, and shall conform to generally accepted auditing standards. When an audit of accounts and records is made by a certified public accountant or public accountant, a report thereof shall be filed as a public record with each Member (and also with the auditor of Sacramento County as the county in which the Authority's office is located) within 12 months after the end of the fiscal year.

e. In any year in which the annual budget of the Authority does not exceed five thousand dollars (\$5,000.00), the Board may, upon unanimous approval of the Board, replace the annual audit with an ensuing one-year period, but in no event for a period longer than two fiscal years.

16. Duties of Members or Associate Members; Breach

If any Member or Associate Member shall default in performing any covenant contained herein, such default shall not excuse that Member or Associate Member from fulfilling its other obligations hereunder, and such defaulting Member or Associate Member shall remain liable for the performance of all covenants hereof. Each Member or Associate Member hereby declares that this Agreement is entered into for the benefit of the Authority created hereby, and each Member or Associate Member hereby grants to the Authority the right to enforce, by whatever lawful means the Authority deems appropriate, all of the obligations of each of the parties hereunder. Each and all of the remedies given to the Authority hereunder or by any law now or hereafter enacted are cumulative, and the exercise of one right or remedy shall not impair the right of the Authority to any or all other remedies.

17. Indemnification

To the full extent permitted by law, the Board may authorize indemnification by the Authority of any person who is or was a Board Delegate, alternate, officer, consultant, employee or other agent of the Authority, and who was or is a party or is threatened to be made a party to a proceeding by reason of the fact that such person is or was such a Delegate, alternate, officer, consultant, employee or other agent of the Authority. Such indemnification may be made against expenses, judgments, fines, settlements and other amounts actually and reasonably incurred in connection with such proceeding, if such person acted in good faith and in a manner such person reasonably believed to be in the best interests of the Authority and, in the case of a criminal

proceeding, had no reasonable cause to believe his or her conduct was unlawful and, in the case of an action by or in the right of the Authority, acted with such care, including reasonable inquiry, as an ordinarily prudent person in a like position would use under similar circumstances.

18. Immunities

All of the privileges and immunities from liabilities, exemptions from law, ordinances and rules, all pension, relief, disability, workers' compensation and other benefits which apply to the activity of officers, agents or employees of any of the Members or Associate Members when performing their respective functions, shall apply to them to the same degree and extent while engaged as Delegates or otherwise as an officer, agent or other representative of the Authority or while engaged in the performance of any of their functions or duties under the provisions of this Agreement.

19. Amendment

This Agreement may be amended by the adoption of the amendment by the governing bodies of a majority of the Members. The amendment shall become effective on the first day of the month following the last required member agency approval. An amendment may be initiated by the Board, upon approval by a majority of the Board. Any proposed amendment, including the text of the proposed change, shall be given by the Board to each Member's Delegate for presentation and action by each Member's board within 60 days, which time may be extended by the Board.

The list of Members, Attachment 1, may be updated to reflect new and/or withdrawn Members without requiring formal amendment of the Agreement by the Authority Board of Directors.

20. Withdrawal of Member or Associate Member

If a Member withdraws as member of RCRC, its membership in the Authority shall automatically terminate. A Member or Associate Member may withdraw from this Agreement upon written notice to the Board; provided however, that no such withdrawal shall result in the dissolution of the Authority as long as any Bonds or other obligations of the Authority remain outstanding. Any such withdrawal shall become effective thirty (30) days after a resolution adopted by the Member's governing body which authorizes withdrawal is received by the Authority. Notwithstanding the foregoing, any termination of membership or withdrawal from the Authority shall not operate to relieve any terminated or withdrawing Member or Associate Member from Obligations incurred by such terminated or withdrawing Member or Associate Member prior to the time of its termination or withdrawal.

20. Miscellaneous

a. **Counterparts.** This Agreement may be executed in several counterparts, each of which shall be an original and all of which shall constitute but one and the same instrument.

b. **Construction.** The section headings herein are for convenience only and are not to

be construed as modifying or governing the language in the section referred to.

c. **Approvals.** Wherever in this Agreement any consent or approval is required, the same shall not be unreasonably withheld.

d. **Jurisdiction; Venue.** This Agreement is made in the State of California, under the Constitution and laws of such State and is to be so construed; any action to enforce or interpret its terms shall be brought in Sacramento County, California.

e. **Integration.** This Agreement is the complete and exclusive statement of the agreement among the parties hereto, and it supersedes and merges all prior proposals, understandings, and other agreements, whether oral, written, or implied in conduct, between and among the parties relating to the subject matter of this Agreement.

f. **Successors; Assignment.** This Agreement shall be binding upon and shall inure to the benefit of the successors of the parties hereto. Except to the extent expressly provided herein, no Member may assign any right or obligation hereunder without the consent of the Board.

g. **Severability.** Should any part, term or provision of this Agreement be decided by the courts to be illegal or in conflict with any law of the State of California, or otherwise be rendered unenforceable or ineffectual, the validity of the remaining parts, terms or provisions hereof shall not be affected thereby.

The parties hereto have caused this Agreement to be executed and attested by their properly authorized officers.

AS ADOPTED BY THE MEMBERS:

Originally dated July 1, 1993
Amended and restated December 10, 1998
Amended and restated February 18, 1999
Amended and restated September 18, 2002
Amended and restated January 28, 2004
Amended and restated December 10, 2014

[SIGNATURES ON FOLLOWING PAGES]

SIGNATURE PAGE FOR NEW ASSOCIATE MEMBERS

NAME OF COUNTY OR CITY:

Dated: _____

By: _____

Name: _____

Title: _____

Attest:

By _____
[Clerk of the Board Supervisors or City Clerk]

AFTER EXECUTION, PLEASE SEND TO:

Golden State Finance Authority
(formerly California Home Finance Authority)
1215 K Street, Suite 1650
Sacramento, CA 95814

ATTACHMENT 1
CALIFORNIA HOME FINANCE AUTHORITY MEMBERS

As of December 10, 2014

Alpine County
Amador County
Butte County
Calaveras County
Colusa County
Del Norte County
El Dorado County
Glenn County
Humboldt County
Imperial County
Inyo County
Lake County
Lassen County
Madera County
Mariposa County
Mendocino County
Merced County
Modoc County
Mono County
Napa County
Nevada County
Placer County
Plumas County
San Benito County
Shasta County
Sierra County
Siskiyou County
Sutter County
Tehama County
Trinity County
Tuolumne County
Yolo County
Yuba County

ATTACHMENT "B"**RESOLUTION NO. 7720****RESOLUTION OF THE CITY COUNCIL OF THE CITY OF SAN FERNANDO, CALIFORNIA CONSENTING TO INCLUSION OF PROPERTIES WITHIN THE CITY'S JURISDICTION IN THE CALIFORNIA HOME FINANCE AUTHORITY COMMUNITY FACILITIES DISTRICT NO. 2014-1 (CLEAN ENERGY) TO FINANCE RENEWABLE ENERGY IMPROVEMENTS, ENERGY EFFICIENCY AND WATER CONSERVATION IMPROVEMENTS AND ELECTRIC VEHICLE CHARGING INFRASTRUCTURE AND APPROVING ASSOCIATE MEMBERSHIP IN THE JOINT EXERCISE OF POWERS AUTHORITY RELATED THERETO**Recitals

WHEREAS, the California Home Finance Authority, a California joint powers authority, (the "Authority") has established the Community Facilities District No. 2014-1(Clean Energy) in accordance with the Mello-Roos Community Facilities Act, set forth in sections 53311 through 53368.3 of the California Government Code (the "Act") and particularly in accordance with sections 53313.5(l) and 53328.1(a) (the "District"); and

WHEREAS, the purpose of the District is to finance or refinance (including the payment of interest) the acquisition, installation, and improvement of energy efficiency, water conservation, renewable energy and electric vehicle charging infrastructure improvements permanently affixed to private or publicly-owned real property (the "Authorized Improvements"); and

WHEREAS, the Authority is in the process of amending the Authority Joint Powers Agreement (the "Authority JPA") to formally change its name to the Golden State Finance Authority; and

WHEREAS, the City of San Fernando is committed to development of renewable energy generation and energy efficiency improvements, reduction of greenhouse gases, and protection of the environment; and

WHEREAS, in the Act, the Legislature has authorized a parcel within the territory of the District to annex to the District and be subject to the special tax levy of the District only (i) if the city or county within which the parcel is located has consented, by the adoption of a resolution by the applicable city council or county board of supervisors, to the inclusion of parcels within its boundaries in the District and (ii) with the unanimous written approval of the owner or owners of the parcel when it is annexed (the "Unanimous Approval Agreement"), which, as provided in section 53329.6 of the Act, shall constitute the election required by the California Constitution; and

WHEREAS, the City wishes to provide innovative solutions to its property owners to achieve energy efficiency and water conservation and in doing so cooperate with Authority in

order to efficiently and economically assist property owners the City in financing such Authorized Improvements; and

WHEREAS, the Authority has established the District, as permitted by the Act, the Authority JPA, originally made and entered into July 1, 1993, as amended to date, and the City, desires to become an Associate Member of the JPA by execution of the JPA Agreement, a copy of which is attached as Exhibit "A" hereto, to participate in the programs of the JPA and, to assist property owners within the incorporated area of the City in financing the cost of installing Authorized Improvements; and

WHEREAS, the City will not be responsible for the conduct of any special tax proceedings; the levy and collection of special taxes or any required remedial action in the case of delinquencies in the payment of any special taxes in connection with the District.

NOW, THEREFORE, THE CITY COUNCIL OF THE CITY OF SAN FERNANDO DOES HEREBY RESOLVE, FIND, DETERMINE, AND ORDER AS FOLLOWS:

1. This City Council finds and declares that properties in the City's incorporated area will be benefited by the availability of the Authority CFD No. 2014-1 (Clean Energy) to finance the installation of the Authorized Improvements.

2. This City Council consents to inclusion in the Authority CFD No. 2014-1 (Clean Energy) of all of the properties in the incorporated area within the City and to the Authorized Improvements, upon the request of and execution of the Unanimous Approval Agreement by the owners of such properties when such properties are annexed, in compliance with the laws, rules and regulations applicable to such program; and to the assumption of jurisdiction thereover by Authority for the purposes thereof.

3. The consent of this City Council constitutes assent to the assumption of jurisdiction by Authority for all purposes of the Authority CFD No. 2014-1 (Clean Energy) and authorizes Authority, upon satisfaction of the conditions imposed in this resolution, to take each and every step required for or suitable for financing the Authorized Improvements.

4. This City Council hereby approves joining the JPA as an Associate Member and authorizes the execution by appropriate City officials of any necessary documents to effectuate such membership.

5. City staff is authorized and directed to coordinate with Authority staff to facilitate operation of the Authority CFD No. 2014-1 (Clean Energy) within the City, and report back periodically to this City Council on the success of such program.

6. This Resolution shall take effect immediately upon its adoption. The City Clerk is directed to send a certified copy of this resolution to the Secretary of the Authority.

PASSED, APPROVED, AND ADOPTED this 7th day of December, 2015.

Joel Fajardo, Mayor

ATTEST:

Elena G. Chávez, City Clerk

STATE OF CALIFORNIA)
COUNTY OF LOS ANGELES) ss
CITY OF SAN FERNANDO)

I HEREBY CERTIFY that the foregoing Resolution was approved and adopted at a regular meeting of the City Council held on the 7th day of December, 2015, by the following vote to wit:

AYES:

NOES:

ABSENT:

Elena G. Chávez, City Clerk

Exhibit A
JPA Agreement
[to be inserted]

EXHIBIT "A"

ASSOCIATE MEMBERSHIP AGREEMENT

by and between the

CALIFORNIA ENTERPRISE DEVELOPMENT AUTHORITY

and the

CITY OF SAN FERNANDO, CALIFORNIA

THIS ASSOCIATE MEMBERSHIP AGREEMENT (this "Associate Membership Agreement"), dated as of _____ by and between CALIFORNIA ENTERPRISE DEVELOPMENT AUTHORITY (the "Authority") and the CITY OF SAN FERNANDO, CALIFORNIA, a municipal corporation, duly organized and existing under the laws of the State of California (the "City");

WITNESSETH:

WHEREAS, the Cities of Selma, Lancaster and Eureka (individually, a "Member" and collectively, the "Members"), have entered into a Joint Powers Agreement, dated as of June 1, 2006 (the "Agreement"), establishing the Authority and prescribing its purposes and powers; and

WHEREAS, the Agreement designates the Executive Committee of the Board of Directors and the President of the California Association for Local Economic Development as the initial Board of Directors of the Authority; and

WHEREAS, the Authority has been formed for the purpose, among others, to assist for profit and nonprofit corporations and other entities to obtain financing for projects and purposes serving the public interest; and

WHEREAS, the Agreement permits any other local agency in the State of California to join the Authority as an associate member (an "Associate Member"); and

WHEREAS, the City desires to become an Associate Member of the Authority;

WHEREAS, City Council of the City has adopted a resolution approving the Associate Membership Agreement and the execution and delivery thereof;

WHEREAS, the Board of Directors of the Authority has determined that the City should become an Associate Member of the Authority;

NOW, THEREFORE, in consideration of the above premises and of the mutual promises herein contained, the Authority and the City do hereby agree as follows:

Section 1. Associate Member Status. The City is hereby made an Associate Member of the Authority for all purposes of the Agreement and the Bylaws of the Authority, the provisions of which are hereby incorporated herein by reference. From and after the date of execution and delivery of this Associate Membership Agreement by the City and the Authority, the City shall be and remain an Associate Member of the Authority.

Section 2. Restrictions and Rights of Associate Members. The City shall not have the right, as an Associate Member of the Authority, to vote on any action taken by the Board of Directors or by the Voting Members of the Authority. In addition, no officer, employee or representative of the City shall have any right to become an officer or director of the Authority by virtue of the City being an Associate Member of the Authority.

Section 3. Effect of Prior Authority Actions. The City hereby agrees to be subject to and bound by all actions previously taken by the Members and the Board of Directors of the Authority to the same extent as the Members of the Authority are subject to and bound by such actions.

Section 4. No Obligations of Associate Members. The debts, liabilities and obligations of the Authority shall not be the debts, liabilities and obligations of the City.

Section 5. Execution of the Agreement. Execution of this Associate Membership Agreement and the Agreement shall satisfy the requirements of the Agreement and Article XII of the Bylaws of the Authority for participation by the City in all programs and other undertakings of the Authority.

IN WITNESS WHEREOF, the parties hereto have caused this Associate Membership Agreement to be executed and attested by their proper officers thereunto duly authorized, on the day and year first set forth above.

**CALIFORNIA ENTERPRISE
DEVELOPMENT AUTHORITY**

By: _____
Gurbax Sahota, Chair
Board of Directors

Attest:

Michelle Stephens, Asst. Secretary

CITY OF SAN FERNANDO, CALIFORNIA

By: _____
Joel Fajardo, Mayor
City Council

Attest:

Elena G. Chavez, City Clerk

*This Page
Intentionally
Left Blank*

10

*This Page
Intentionally
Left Blank*



AGENDA REPORT

To: Mayor Joel Fajardo and Councilmembers

From: Brian Saeki, City Manager
By: Chris Marcarello, Deputy City Manager/Public Works Director

Date: December 7, 2015

Subject: Consideration to Approve Consultant Agreement and Memorandum of Understanding Related to State of California Department of Transportation (Caltrans) Community Sustainable Transportation Planning Grant

RECOMMENDATION:

It is recommended that the City Council:

- a. Adopt Resolution No. 7715 (Attachment "A"), appropriating \$144,200 in grant funding under the Caltrans Sustainable Transportation Planning Grant Program;
- b. Following receipt of a Notice to Proceed from Caltrans related to this grant, confirm the selection of Evans Brooks and Associates for consultant services related to this program (to be funded entirely by grant funding) using the City's existing on-call services agreement (Attachment "B" – Contract No. 1802 (7 of 16));
- c. Authorize the City Manager or designee to execute a Professional Services Agreement (Attachment "C" – Contract No. 1807) with the California Center for Public Health Advocacy for outreach services related to this program (to be funded entirely by grant funding); and
- d. Authorize the City Manager or designee to execute a Memorandum of Understanding (MOU) (Attachment "D" – Contract No. 1808) with the County of Los Angeles Department of Public Health for services related to the preparation of an Active Transportation Program Plan for the City of San Fernando at no cost to the City.

BACKGROUND:

In October 2014, a grant application was submitted to the State of California Department of Transportation under the Fiscal Year 2015-16 Sustainable Transportation Planning Grant Program. Approximately \$8.3 Million was available under this program with a required local matching contribution of 11.47% of the total grant award. In 2015, the City of San Fernando was awarded a grant under this program in the amount of \$144,200 to create a Citywide Safe

Consideration to Approve Consultant Agreement and Memorandum of Understanding Related to State of California Department of Transportation (Caltrans) Community Sustainable Transportation Planning Grant

Page 2 of 4

Routes to School Plan. As part of the grant requirement, the City will contribute a local matching contribution of \$18,683 using in-kind (staff assistance) contributions. On November 16, 2015, the City Council approved a resolution authorizing the reimbursement of costs related to this program.

ANALYSIS:

The State of California Sustainable Transportation Planning Grant Program was designed to help local agencies develop plans that help promote a balanced multi-modal transportation system. Using these comprehensive transportation plans, it is hoped that communities will be able to initiate and develop physical transportation improvements that help to promote a safe, sustainable, integrated and efficient transportation system in local communities. Using this framework, the City will work to identify and address mobility deficiencies in the community's transportation system while involving active participation from local stakeholders, including schools, parents, community groups and the community at-large.

As proposed through this grant program, the City will work to develop a Safe Routes to School Plan (Plan) for the entire community. The Plan will study local safety hazards and conditions faced by school-aged children traveling to and from school. Extensive outreach will be conducted involving local school officials, parents, community stakeholders, and City representatives. Overall, the Plan will help to increase dialog related to transportation safety in the community and help to encourage the increased usage of walking and bicycling to neighborhood school campuses. Once complete, the Plan will provide the City with a written document that helps to identify school routes, traffic safety measures, and recommendations for infrastructure improvements to enhance community safety.

The planning effort will entail the following elements:

- Community Advisory Working Group
Through the City's Transportation and Safety Commission, develop a Safe Routes to School Advisory Working Group that helps to guide the development of the Community Safe Routes to School Plan. This Advisory Group will include community residents, local business representatives, school officials, community groups, and staff members.
- Outreach/Community Participation
The planning effort will entail the following:
 - Two (2) educational workshops for the community to provide information that will guide school campus assessments and help to analyze improvements that are needed to increase walking and bicycling to school.

Consideration to Approve Consultant Agreement and Memorandum of Understanding Related to State of California Department of Transportation (Caltrans) Community Sustainable Transportation Planning Grant

Page 3 of 4

- Three (3) neighborhood charrettes/tours will be conducted at local school campuses to evaluate campus conditions and engage school officials related to improving walking/bicycling at local schools. These events will also include an activity for 5th and 6th grade students to draw their routes to school and identify possible safety hazards along their route.
- Community-wide distribution of flyers and mailers to increase awareness of this planning effort.
- Planning/Analysis of Existing Conditions
As part of this Plan, existing community and transportation plans will be reviewed, including traffic volumes, accident data, and capital improvement plans. Bicycle and pedestrian counting equipment will be temporarily installed at key locations to gain a better understanding of local activity in the community. Using this data and stakeholder input, proposed plans will be developed to address deficiencies that are identified.
- Report Preparation
A written document will be prepared including conceptual designs, pedestrian/bicycle routes, and recommended improvements to improve local pedestrian and bicycle conditions. This information will be reviewed with the Advisory Working Group, the Transportation Commission and the City Council.

Consultant Services Request for Proposals (RFP)

In November, an RFP for consulting services related to this grant program was circulated among several of the City's on-call engineering and transportation services firms. The scope of work includes participation in planning/community meetings, preparation of drawings/maps related to the program, and preparation of a written document that includes conceptual improvement designs and recommended improvements for the San Fernando community. Based on this RFP, proposals were received from the following firms:

AIM Consulting Services
Evans Brooks Associates
Willdan

After a thorough review of these proposals, it was determined that the proposal submitted by Evans Brooks Associates (EBA) best meets the needs of the City. This proposal was selected due to EBA's focus on bilingual immersion programs used for community outreach activities and its in-depth assessment of existing community conditions. Prior to the development of its proposal, EBA staff conducted a preliminary bicycle tour of local schools to gain an understanding of conditions faced by students and parents while traveling to/from school. Based on these elements, it is recommended that the City Council confirm this selection for consulting services under the City's existing on-call services agreement in an amount not-to-

Consideration to Approve Consultant Agreement and Memorandum of Understanding Related to State of California Department of Transportation (Caltrans) Community Sustainable Transportation Planning Grant

Page 4 of 4

exceed \$87,050. If approved by the City Council, a professional services agreement would be executed following the receipt of a Notice to Proceed from Caltrans related to this grant program.

Professional Services Agreement with California Center for Public Health Advocacy (CCPHA)

As part of the original grant application, it was contemplated that the CCPHA would provide the bulk of outreach and community organizing services as part of this program. It is recommended that the City Council authorize the City Manager or designee to execute this agreement, authorizing the CCPHA to perform these functions and be eligible for reimbursement under this grant program in an amount not-to-exceed \$57,150. Again, this agreement would be executed following the receipt of a Notice to Proceed from Caltrans related to this grant program.

Memorandum of Understanding (MOU) with County of Los Angeles

As part of this effort, the County of Los Angeles has agreed to prepare an Active Transportation Plan at no cost to the City. The Active Transportation Plan will integrate pedestrian and bicycle planning efforts with other multi-modal forms of transportation, including mass transit, local transit, and vehicle travel, among others. It is recommended that the City Council authorize the City Manager or designee to execute this MOU, authorizing the performance of these functions.

CONCLUSION:

It is recommended that the City Council approve the related actions related to this grant-funded program. The Safe Routes to School and Active Transportation planning efforts will help to improve pedestrian safety, increase transportation opportunities, and better position the City for future infrastructure grant opportunities. All program elements will be funded entirely through grant funds.

ATTACHMENTS:

- A. Resolution No. 7715
- B. Contract No. 1802 (7 of 16)
- C. Contract No. 1807
- D. Contract No. 1808

ATTACHMENT "A"**RESOLUTION NO. 7715****A RESOLUTION OF THE CITY COUNCIL OF THE CITY OF SAN FERNANDO, CALIFORNIA, AMENDING THE BUDGET FOR THE FISCAL YEAR 2015-16 ADOPTED ON JUNE 15, 2015**

WHEREAS, the City of Council has received and considered the proposed adjustment to the budget for Fiscal Year 2015-16, commencing July 1, 2015, and ending June 30, 2016; and

WHEREAS, the City Council has determined that it is necessary to amend the revenues and expenditures of the current City budget; and

WHEREAS, the City received a grant from the State of California Department of Transportation under the Sustainable Transportation Planning Grant program for the creation of a Safe Routes to School Master Plan for the community; and

WHEREAS, the City Council approved Resolution No. 7713 on November 16, 2015 related to obtaining expense reimbursements from the State of California Department of Transportation as part of this grant program; and

WHEREAS, the City desires to initiate work as part of the grant program; and

WHEREAS, an annual budget for the City of San Fernando for the Fiscal Year beginning July 1, 2015 and ending June 30, 2016, a copy of which is on file in the City Clerk's Office, has been adopted on June 15, 2015.

NOW THEREFORE, THE CITY COUNCIL OF THE CITY OF SAN FERNANDO, DOES HEREBY RESOLVE, FIND, DETERMINE, AND ORDER AS FOLLOWS:

Section 1. The following adjustments are made to the City Budget:

Increase Revenue(s):

CalTrans Sust. Transit Planning Grant (010-3686-0687)	\$144,200
---	-----------

Increase Expenditure(s):

Professional Services (010-310-0687-4270)	\$144,200
---	-----------

Total Expenditure Adjustment:	\$144,200
-------------------------------	-----------

Total Revenue Adjustment:	\$144,200
---------------------------	-----------

PASSED, APPROVED, AND ADOPTED this 7th day of December, 2015.

Joel Fajardo, Mayor

ATTEST:

Elena G. Chávez, City Clerk

STATE OF CALIFORNIA)
COUNTY OF LOS ANGELES) ss
CITY OF SAN FERNANDO)

I HEREBY CERTIFY that the foregoing Resolution was approved and adopted at a regular meeting of the City Council held on the 7th day of December, 2015, by the following vote to wit:

AYES:

NOES:

ABSENT:

Elena G. Chávez, City Clerk



2015

PROFESSIONAL SERVICES AGREEMENT
(On-Call Engineering & Plan Check Services)

THIS PROFESSIONAL SERVICES AGREEMENT (“Agreement”) is entered into this 17th day of August 2015 (hereinafter, the “Effective Date”), by and between the CITY OF SAN FERNANDO, a municipal corporation and general law city (“CITY”) and Evan Brooks Associates, Incorporated (hereinafter, “CONSULTANT”). The capitalized term “Parties” shall be a collective reference to both CITY and CONSULTANT. The capitalized term “Party” shall refer to either CITY or CONSULTANT interchangeably as appropriate.

RECITALS

THIS AGREEMENT is made and entered into with respect to the following facts:

WHEREAS, CITY, pursuant to California Government Code Sections 37103 and 53060, is authorized and empowered to contract with any specially trained and experienced firm or corporation for special services and advice on financial, economic, accounting, engineering, legal or administrative matters; and

WHEREAS, CITY’s in-house personnel are not able to provide the types of specialized consulting services required under this engagement; and

WHEREAS, CITY requires the performance of on-call professional engineering and plan check services in connection with the Public Works, Community Development and Parks and Recreation Department’s capital improvement projects; and

WHEREAS, CONSULTANT represents that it is fully qualified to perform such professional services by virtue of its experience and the training, education and expertise of its principals, employees and subcontractors; and

WHEREAS, the execution of this Agreement was approved by the City Council in accordance with the CITY’s procurement and purchasing procedures at the City Council’s meeting of August 17, 2015 under Agenda Item Seven (7) ; and

WHEREAS, CONSULTANT further represents that it is willing to accept responsibility for performing such services in accordance with the terms and conditions set forth in this Agreement.

NOW, THEREFORE, FOR AND IN CONSIDERATION OF THE MUTUAL COVENANTS AND CONDITIONS HEREIN CONTAINED, CITY AND CONSULTANT AGREE AS FOLLOWS:

SCOPE AND PROSECUTION OF WORK; COMPENSATION

1.1 **SCOPE OF WORK:** Subject to the terms and conditions set forth in this Agreement and all exhibits attached and incorporated hereto, CONSULTANT agrees to perform the services and tasks set forth in that certain proposal entitled: Proposal for Professional Engineering and Plan Check Review Services dated as of July 31, 2015 which included a "Fee Schedule" and is attached and incorporated hereto **Exhibit "A"** (hereinafter the "Compensation Schedule"). CONSULTANT further agrees to furnish to CITY labor, materials, tools, supplies, equipment, services, tasks and incidental and customary work necessary to competently perform and timely complete the services and tasks set forth in the Scope of Work. For the purposes of this Agreement the aforementioned services and tasks set forth in the Scope of Work shall hereinafter be referred to generally by the capitalized term "Work." The Work is inclusive of those tasks that may be identified as being optional under the Scope of Work and such optional work shall not constitute Extra Work under Section 1.5 of this Agreement, below. Neither CONSULTANT nor anyone acting on CONSULTANT's behalf shall commence with the performance of the Work or any other related tasks until CITY issues a written notice to proceed (hereinafter, the "Notice to Proceed").

1.2 TERM:

- A. This Agreement shall have a term of Three (3) Years following City Council approval commencing on (August 17, 2015 to August 17, 2018) (hereinafter, the "Initial Term").
- B. This Agreement may be extended subject to the same terms and conditions set forth herein for a maximum of Two (2) years, at the sole and absolute discretion of CITY MANAGER, provided CITY MANAGER issues written notice of its intent to so extend the Agreement no less than thirty (30) calendar days prior to the expiration of the Initial Term or any subsequent extension term. Nothing in this subsection shall operate to prohibit or otherwise restrict CITY right to terminate this Agreement at any time for convenience or for cause as provided herein.
- C. Nothing in this Section shall operate to prohibit or otherwise restrict the CITY's ability to terminate this Agreement at any time for convenience or for cause.

1.3 COMPENSATION AND COMPENSATION CONTROLS:

- A. At the request of City staff, CONSULTANT shall submit a proposal for services to be performed and complete all of the services and tasks for that project or program, at the rates of compensation set forth in that certain compensation schedule set forth within Exhibit of the Scope of Work under the heading the

Compensation Schedule. CONSULTANT shall provide copies of receipts and invoices corroborating all costs or expenses, as requested by the City. CITY shall be under no obligation to reimburse CONSULTANT for unsubstantiated costs or expenses.

- B. CONSULTANT understands and agrees that the City does not guarantee or have an obligation to approve ANY proposal for Engineering and Plan Check Services requested by City during the Initial Term of Agreement or the duration of any approved contract extensions.

1.4 PAYMENT OF COMPENSATION:

- A. CITY shall compensate CONSULTANT on a monthly basis as tasks are performed and the Work is completed to the reasonable satisfaction of CITY. Following the conclusion of each month during the Initial Term of this Agreement or any extension term, CONSULTANT shall submit to CITY a monthly itemized invoice or statement identifying the tasks performed, hours of service rendered and reimbursable pass-through costs incurred by CONSULTANT and its various employees during the recently concluded month.
- B. Within thirty (30) calendar days of receipt of each invoice, CITY shall notify CONSULTANT in writing of any disputed charges, costs or expenses included in the invoice. Within forty-five (45) calendar days of receipt of each invoice, CITY shall pay all undisputed charges, costs and expenses indicated in CONSULTANT's monthly invoice.
- C. CITY shall not withhold applicable taxes or other authorized deductions from payments made to CONSULTANT.

1.5 EXTRA WORK; COMPENSATION FOR EXTRA WORK:

- A. At any time during the term of this Agreement, CITY may request that CONSULTANT perform Extra Work. For the purposes of this Agreement, the term "Extra Work" means any additional work, services or tasks not set forth in the Scope of Work but later determined by CITY to be necessary. CONSULTANT shall not undertake nor shall CONSULTANT be entitled to compensation for Extra Work without the prior written authorization of the CITY. Extra Work does not include any labor, materials, tools, supplies, equipment, services, tasks or incidental and customary work undertaken to competently perform and timely complete the Work and related tasks set forth in the Scope of Work.
- B. Payments for any Extra Work shall be made to CONSULTANT on a time-and-materials basis using CONSULTANT's standard fee schedule.

- 1.6 ACCOUNTING RECORDS: CONSULTANT shall maintain complete and accurate records with respect to all matters covered under this Agreement for a period of three (3) years after the expiration or termination of this Agreement. CITY shall have the right to access and examine such records, without charge, during normal business hours. CITY shall further

have the right to audit such records, to make transcripts therefrom and to inspect all program data, documents, proceedings, and activities.

- 1.7 ABANDONMENT BY CONSULTANT: In the event CONSULTANT ceases to perform the Work agreed to under this Agreement or otherwise abandons the undertaking contemplated herein prior to the expiration of this Agreement or prior to completion of any or all tasks set forth in the Scope of Work, CONSULTANT shall deliver to CITY immediately and without delay, all materials, records and other work product prepared or obtained by CONSULTANT in the performance of this Agreement. Furthermore, CONSULTANT shall only be compensated for the reasonable value of the services, tasks and other work performed up to the time of cessation or abandonment, less a deduction for any damages, costs or additional expenses which CITY may incur as a result of CONSULTANT's cessation or abandonment.

II.

PERFORMANCE OF AGREEMENT

- 2.1 CITY'S REPRESENTATIVES: The CITY hereby designates the Director of Public Works (hereinafter, the "CITY Representatives") to act as its representative for the performance of this Agreement. The CITY Representative or his designee shall act on behalf of the CITY for all purposes under this Agreement. CONSULTANT shall not accept directions or orders from any person other than the CITY Representatives or their designee.
- 2.2 CONSULTANT'S REPRESENTATIVE: CONSULTANT hereby designates Hal Suetsugu, President- Managing Partner, to act as its representative for the performance of this Agreement (hereinafter, "Consultant's Representative"). CONSULTANT's Representative shall have full authority to represent and act on behalf of the CONSULTANT for all purposes under this Agreement. Consultant's Representative or his designee shall supervise and direct the performance of the Work, using his/her best skill and attention, and shall be responsible for all means, methods, techniques, sequences and procedures and for the satisfactory coordination of all portions of the Work under this Agreement. Notice to the Consultant's Representative shall constitute notice to CONSULTANT.
- 2.3 COORDINATION OF SERVICE; CONFORMANCE WITH REQUIREMENTS: CONSULTANT agrees to work closely with CITY staff in the performance of the Work and this Agreement and shall be available to CITY staff and the CITY Representatives at all reasonable times. All work prepared by CONSULTANT shall be subject to inspection and approval by CITY Representatives or their designees.
- 2.4 STANDARD OF CARE; PERFORMANCE OF EMPLOYEES: CONSULTANT represents, acknowledges and agrees to the following:
- A. CONSULTANT shall perform all work skillfully, competently and to the highest standards applicable to the CONSULTANT's profession;
 - B. CONSULTANT shall perform all work in a manner reasonably satisfactory to the CITY;

- C. CONSULTANT shall comply with all applicable federal, state and local laws and regulations, including the conflict of interest provisions of Government Code Section 1090 and the Political Reform Act (Government Code Section 81000 *et seq.*);
- D. CONSULTANT understands the nature and scope of the Work to be performed under this Agreement as well as any and all schedules of performance;
- E. All of CONSULTANT's employees and agents (including but not limited to CONSULTANT's subcontractors and subconsultants) possess sufficient skill, knowledge, training and experience to perform those services and tasks assigned to them by CONSULTANT; and
- F. All of CONSULTANT's employees and agents (including but not limited to CONSULTANT's subcontractors and subconsultants) possess all licenses, permits, certificates, qualifications and approvals of whatever nature that are legally required to perform the tasks and services contemplated under this Agreement and all such licenses, permits, certificates, qualifications and approvals shall be maintained throughout the term of this Agreement.

The Parties acknowledge and agree that CONSULTANT shall perform, at CONSULTANT's own cost and expense and without any reimbursement from CITY, any services necessary to correct any errors or omissions caused by CONSULTANT's failure to comply with the standard of care set forth under this Section or by any like failure on the part of CONSULTANT's employees, agents, contractors, subcontractors and subconsultants. Such effort by CONSULTANT to correct any errors or omissions shall be commenced immediately upon their discovery by either Party and shall be completed within seven (7) calendar days from the date of discovery or such other extended period of time authorized by the CITY Representatives in writing and absolute discretion. The Parties acknowledge and agree that CITY's acceptance of any work performed by CONSULTANT or on CONSULTANT's behalf shall not constitute a release of any deficiency or delay in performance. The Parties further acknowledge, understand and agree that CITY has relied upon the foregoing representations of CONSULTANT, including but not limited to the representation that CONSULTANT possesses the skills, training, knowledge and experience necessary to perform the Work in a skillful and competent manner equivalent to, the standard of performance generally recognized as being employed by professionals performing the same type of work and services in the State of California.

2.5 ASSIGNMENT: The skills, training, knowledge and experience of CONSULTANT are material to CITY's willingness to enter into this Agreement. Accordingly, CITY has an interest in the qualifications and capabilities of the person(s) who will perform the services and tasks to be undertaken by CONSULTANT or on behalf of CONSULTANT in the performance of this Agreement. In recognition of this interest, CONSULTANT agrees that it shall not assign or transfer, either directly or indirectly or by operation of law, this Agreement or the performance of any of CONSULTANT's duties or obligations under this Agreement without the prior written consent of the CITY. In the absence of CITY's prior written consent, any attempted assignment or transfer shall be ineffective, null and void and shall constitute a material breach of this Agreement.

- 2.6 CONTROL AND PAYMENT OF SUBORDINATES: The Work shall be performed by CONSULTANT or under CONSULTANT's strict supervision. CONSULTANT will determine the means, methods and details of performing the Work subject to the requirements of this Agreement. CITY retains CONSULTANT on an independent contractor basis and not as an employee. CONSULTANT reserves the right to perform similar or different services for others during the term of this Agreement, provided such work does not unduly interfere with CONSULTANT's competent performance under this Agreement or result in the unauthorized disclosure of CITY's confidential or proprietary information. Any additional personnel performing the Work under this Agreement on behalf of CONSULTANT are not employees of CITY and shall at all times be under CONSULTANT's exclusive direction and control. CONSULTANT shall pay all wages, salaries and other amounts due such personnel and shall assume responsibility for all benefits, payroll taxes, social security and Medicare payments and the like. CONSULTANT shall be responsible for all reports and obligations respecting such additional personnel, including, but not limited to: social security taxes, income tax withholding, unemployment insurance, disability insurance, workers' compensation insurance and the like.
- 2.7 REMOVAL OF EMPLOYEE OR AGENTS: If any of CONSULTANT's officers, employees, agents, contractors, subcontractors or subconsultants is determined by the CITY Representatives to be uncooperative, incompetent, a threat to the adequate or timely performance of the tasks assigned to CONSULTANT, a threat to persons or property, or if any of CONSULTANT's officers, employees, agents, contractors, subcontractors or subconsultants fail or refuse to perform the work in a manner acceptable to the CITY such officer, employee, agent, contractor, subcontractor or subconsultant shall be promptly removed by CONSULTANT and shall not be re-assigned to perform any of the work.
- 2.8 COMPLIANCE WITH LAWS: CONSULTANT shall keep itself fully informed of and in compliance with all applicable laws, statutes, codes, rules, regulations and ordinances of the federal government of the United States of America, the State of California, the County of Los Angeles, and any other local governmental entity to the extent such laws, statutes, codes, rules, regulations or ordinances governing or affecting the performance of the Work.
- 2.9 SAFETY: CONSULTANT shall perform its work so as to avoid injury or damage to any person or property. In performing the Work, CONSULTANT shall at all times be in compliance with all applicable local, state and federal laws, rules and regulations, and shall exercise all necessary precautions for the safety of employees appropriate to the nature of the Work and the conditions under which any work is to be performed.
- 2.10. NON-DISCRIMINATION: In the performance of this Agreement, CONSULTANT shall not discriminate against any employee, subcontractor, subconsultant, or applicant for employment because of race, color, creed, religion, sex, marital status, sexual orientation, national origin, ancestry, age, physical or mental disability or medical condition.
- 2.11. INDEPENDENT CONTRACTOR: The Parties acknowledge, understand and agree that CONSULTANT and all persons retained or employed by CONSULTANT are, and shall at all times remain, wholly independent contractors and are not officials, officers, employees, departments or subdivisions of CITY. CONSULTANT shall be solely responsible for the supervision of its employees, agents, contractors, subcontractors and subconsultants and for

the negligent acts and/or omissions of the same. All persons retained or employed by CONSULTANT shall have no authority, express or implied, to bind CITY in any manner, nor to incur any obligation, debt or liability of any kind on behalf of, or against, CITY, whether by contract or otherwise, unless such authority is expressly conferred to CONSULTANT under this Agreement or is otherwise expressly conferred by CITY in writing.

III. INSURANCE

- 3.1 DUTY TO PROCURE AND MAINTAIN INSURANCE: As more specifically set forth below under this Article, CONSULTANT agrees that it shall procure and maintain throughout the Initial Term of this Agreement and any extension term (or for such extended period of time as may be required under this Article) insurance against claims for death or injuries to persons or damages to property that may arise from or in connection with CONSULTANT's performance of this Agreement. CONSULTANT shall also procure and maintain such other types of insurance as may be required under this Article, below. CITY shall not, and shall be under no obligation to, issue a Notice to Proceed until CONSULTANT has provided evidence satisfactory to CITY that it has procured all insurance required under this Article.
- 3.2 REQUIRED COVERAGES AND LICENSES: CONSULTANT agrees that it shall procure and maintain the following insurance coverage, at its own expense, for the duration for this Agreement or any extended period set forth herein:
- A. Business License: CONSULTANT shall procure and maintain a City of San Fernando Business License throughout the Initial Term of Agreement and the duration of any contract extensions.
 - B. Commercial General Liability Insurance: CONSULTANT shall procure and maintain Commercial General Liability Insurance ("CGL Coverage") as broad as Insurance Services Office Commercial General Liability coverage (occurrence Form CG 0001 or equivalent). Such CGL Coverage shall have minimum limits of no less than One Million Dollars (\$1,000,000.00) per occurrence for bodily injury, personal injury, property damage, operations, products and completed operations, and contractual liability and Two Million Dollars (\$2,000,000.00) in the aggregate.
 - C. Automobile Liability Insurance: CONSULTANT shall procure and maintain Automobile Liability Insurance as broad as Insurance Services Office Form Number CA 0001 covering Automobile Liability, Code 1 (any auto). Such Automobile Liability Insurance shall have minimum limits of no less than One Million Dollars (\$1,000,000.00) per accident for bodily injury and property damage.
 - D. Workers' Compensation Insurance/ Employer's Liability Insurance: CONSULTANT shall procure and maintain Workers' Compensation Insurance affording coverage at least as broad as that required by the State of California with Employer's Liability Insurance with minimum limits of no less than One Million Dollars (\$1,000,000.00) per accident

for bodily injury or disease. The Workers' Compensation insurer shall also agree to waive all rights of subrogation against CITY, the City Council and CITY's elected and appointed officials, officers, employees, agents and volunteers for losses paid under the terms of the insurance policy.

- E. Professional Liability Insurance: For the full term of this Agreement and for a period of three (3) years thereafter, CONSULTANT shall procure and maintain Errors and Omissions Liability Insurance appropriate to CONSULTANT's profession. Such coverage shall have minimum limits of no less than One Million Dollars (\$1,000,000.00) per claim and shall be endorsed to include contractual liability.

- 3.3 ADDITIONAL INSURED REQUIREMENTS: The CGL Coverage and the Automobile Liability Insurance shall contain an endorsement naming the CITY, the City Council and CITY's elected and appointed officials, officers, employees, agents and volunteers as additional insureds.
- 3.4 REQUIRED CARRIER RATING: All varieties of insurance required under this Agreement shall be procured from insurers licensed in the State of California and authorized to issue policies directly to California insureds. Except as otherwise provided elsewhere under this Article, all required insurance shall be procured from insurers, who according to the latest edition of the Best's Insurance Guide have an A.M. Best's rating of no less than A:VII. CITY may also accept policies procured by insurance carriers with a Standard & Poor's rating of no less than BBB according to the latest published edition the Standard & Poor's rating guide. As to Workers' Compensation Insurance/ Employer's Liability Insurance, the CITY Representatives are authorized to authorize lower ratings than those set forth in this Section.
- 3.5 PRIMACY OF CONSULTANT'S INSURANCE: All policies of insurance provided by CONSULTANT shall be primary to any coverage available to CITY, the City Council and CITY's elected and appointed officials, officers, employees, agents and volunteers. Any insurance or self-insurance maintained by CITY, the City Council and CITY's elected and appointed officials, officers, employees, agents and volunteers shall be in excess of CONSULTANT's insurance and shall not contribute with it.
- 3.6 WAIVER OF SUBROGATION: All insurance coverage provided pursuant to this Agreement shall not prohibit CONSULTANT or CONSULTANT's officers, employees, agents, subcontractors or subconsultants from waiving the right of subrogation prior to a loss. CONSULTANT hereby waives all rights of subrogation against CITY.
- 3.7 VERIFICATION OF COVERAGE: CONSULTANT acknowledges, understands and agrees that CITY's ability to verify the procurement and maintenance of the insurance required under this Article is critical to safeguarding the CITY's financial well-being. Accordingly, CONSULTANT warrants, represents and agrees that it shall furnish CITY with original certificates of insurance and endorsements evidencing the coverage required under this Article on forms satisfactory to CITY in its sole and absolute discretion. **The certificates of insurance and endorsements for each insurance policy shall be signed by a person authorized by that insurer to bind coverage on its behalf, and shall be on forms provided by the CITY if requested.** All certificates of insurance and endorsements shall be received and approved by CITY as a condition precedent to CONSULTANT's

commencement of any work or any of the Work. Upon CITY's written request, CONSULTANT shall also provide CITY with certified copies of all required insurance policies as a condition precedent to the commencement of any work or any of the Work. CITY shall not, and shall be under no obligation to, issue a Notice to Proceed until CONSULTANT fully complies with this Section. The requirements of this Section cannot be waived and any attempted waiver shall be void, invalid and non-binding upon CITY.

- 3.8 FAILURE TO ADHERE TO INSURANCE PROVISIONS: In addition to any other remedies CITY may have under this Agreement or at law or in equity, if CONSULTANT fails to comply with any of the requirements set forth in this Article, CITY may, but shall not be obligated to: (i) Order CONSULTANT to stop any and all work under this Agreement or withhold any payment, which becomes due to CONSULTANT hereunder, or both stop work and withhold any payment, until CONSULTANT demonstrates compliance with the requirements hereof; or (ii) terminate this Agreement. CITY's exercise of any of the foregoing remedies, shall be in addition to any other remedies CITY may have and is not the exclusive remedy for CONSULTANT's to failure to comply with the insurance requirements set forth under this Article.
- 3.9 SUBCONTRACTORS INSURANCE COVERAGE: CONSULTANT shall include all persons and entities performing work on its behalf as insureds (including all contractors, subcontractors and subconsultants) or, in the alternative, shall furnish separate certificates of insurance and endorsements for each such persons or entities evidencing their independent procurement of insurance. All coverages for such persons or entities shall be identical to the requirements imposed upon CONSULTANT under this Article.
- 3.10 NO LIMITATION ON LIABILITY: CONSULTANT's procurement of insurance shall not be construed as a limitation of CONSULTANT's liability or as full performance of CONSULTANT's indemnification duties set forth under Article V of this Agreement.

IV. INDEMNIFICATION

- 4.1 The Parties agree that City, elected and appointed officials, officers, employees, agents and volunteers (hereinafter, the "City Indemnitees") should, to the fullest extent permitted by law, be protected from any and all loss, injury, damage, claim, lawsuit, cost, attorneys' fees, litigation costs, or any other cost arising out of or in any way related to the performance of this Agreement. Accordingly, the provisions of this indemnity provision are intended by the Parties to be interpreted and construed to provide the City Indemnitees with the fullest protection possible under the law. Consultant acknowledges that City would not enter into this Agreement in the absence of Consultant's commitment to indemnify, defend and protect the City as set forth herein.
- 4.2 To the fullest extent permitted by law, the Consultant shall (i) immediately defend and (ii) indemnify and hold harmless the City and its engineer, elected and appointed officials, officers, agents, employees, attorneys, servants, volunteers, successors and assigns from and against any and all liabilities, regardless of nature or type that arise out of, pertain to, or relate

to the negligence, recklessness, or willful misconduct of the Consultant, or its officers, employees, servants, agents, subcontractors, volunteers or any other person or entity involved by, for, with or on behalf of Consultant in the performance of this Agreement. The parties understand and agree that the duty of Consultant to indemnify and hold harmless includes the duty to defend as set forth in Section 2778 of the California Civil Code. Liabilities subject to the duties to defend and indemnify include, without limitation, all claims, losses, damages, penalties, fines, and judgments; associated investigation and administrative expenses; defense costs, including but not limited to reasonable attorneys' fees incurred by legal counsel of City's choosing; court costs; and costs of alternative dispute resolution. The Consultant's obligation to indemnify applies unless it is finally adjudicated that the liability was caused by the sole active negligence or sole willful misconduct of an indemnified party. If it is finally adjudicated that liability is caused by the comparative active negligence or willful misconduct of an indemnified party, then Consultant's indemnification obligation shall be reduced in proportion to the established comparative liability.

- 4.3 The duty to defend is a separate and distinct obligation from Consultant's duty to indemnify. Consultant shall be obligated to defend, in all legal, equitable, administrative, or special proceedings, with counsel approved by the City, City and its engineer, elected and appointed officials, officers, agents, employees, attorneys, servants, volunteers, successors and assigns, immediately upon tender to City of the claim in any form or at any stage of an action or proceeding, whether or not liability is established. An allegation or determination that persons other than Consultant are responsible for the claim does not relieve Consultant from its separate and distinct obligation to defend under this section. The obligation to defend extends through final judgment, including exhaustion of any appeals. The defense obligation includes an obligation to provide independent defense counsel if Consultant asserts that liability is caused in whole or in part by the negligence or willful misconduct of the indemnified party. If it is finally adjudicated that liability was caused by the comparative active negligence or willful misconduct of an indemnified party, Consultant may submit a claim to the City for reimbursement of reasonable attorneys' fees and defense costs in proportion to the established comparative liability of the indemnified party.
- 4.4 City shall have the right to offset against the amount of any compensation due Consultant under this Agreement any amount due City from Consultant as a result of Consultant's failure to pay City promptly any indemnification arising under this Article and related to Consultant's failure to either (i) pay taxes on amounts received pursuant to this Agreement or (ii) comply with applicable workers' compensation laws.
- 4.5 The obligations of Consultant under this Article will not be limited by the provisions of any workers' compensation act or similar act. Consultant expressly waives its statutory immunity under such statutes or laws as to City and City's engineer, elected and appointed officials, officers, employees, agents and volunteers.
- 4.6 Consultant agrees to obtain executed indemnity agreements with provisions identical to those set forth here in this Article from each and every subcontractor or any other person or entity involved by, for, with or on behalf of Consultant in the performance of this Agreement. In the event Consultant fails to obtain such indemnity obligations from others as required herein, Consultant agrees to be fully responsible and indemnify, hold harmless and defend City and City's engineer, elected and appointed officials, officers, employees, agents and

volunteers from and against any and all claims and losses, costs or expenses for any damage due to death or injury to any person and injury to any property resulting from any alleged intentional, reckless, negligent, or otherwise wrongful acts, errors or omissions of Consultant's subcontractors or any other person or entity involved by, for, with or on behalf of Consultant in the performance of this Agreement. Such costs and expenses shall include reasonable attorneys' fees incurred by counsel of City's choice.

- 4.7 The City does not, and shall not; waive any rights that it may possess against Consultant because of the acceptance by the City, or the deposit with the City, of any insurance policy or certificate required pursuant to this Agreement. This hold harmless and indemnification provision shall apply regardless of whether or not any insurance policies are determined to be applicable to the claim, demand, damage, liability, loss, cost or expense.
- 4.8 This Article and all provisions contained herein (including but not limited to the duty to indemnify, defend and hold free and harmless) shall survive the termination or normal expiration of this Agreement and is in addition to any other rights or remedies which the City may have at law or in equity.

V.

TERMINATION

- 5.1 TERMINATION WITHOUT CAUSE: CITY may terminate this Agreement at any time for convenience and without cause by giving written notice to CONSULTANT at least five (5) calendar days prior to the effective date of such termination for convenience. Upon termination for convenience, CONSULTANT shall be compensated only for the Work which has been adequately rendered to CITY up to the effective date of the termination, and CONSULTANT shall be entitled to no further compensation. CONSULTANT may not terminate this Agreement except for breach of this Agreement. If this Agreement is terminated as provided herein, CITY may require CONSULTANT to provide all finished or unfinished Documents and Data, as defined in Section 7.1 below, and other information of any kind prepared by CONSULTANT in connection with the performance of the Work. CONSULTANT shall be required to provide such documents and other information within fifteen (15) calendar days of the request. In the event this Agreement is terminated in whole or in part as provided herein, CITY may procure, upon such terms and in such manner as it may determine appropriate, Work similar to those terminated.
- 5.2 DEFAULT, BREACH AND TERMINATION IN THE EVENT OF BREACH: In the event either Party fails to perform, or adhere to, any applicable duty, obligation or standard of conduct set forth under this Agreement (or fails to perform or adhere to any such duty, obligation or standard of conduct at the time, place or manner set forth in this Agreement), an event of default (hereinafter, "Event of Default") shall have occurred. Except as otherwise provided in this Agreement, if an Event of Default remains uncured by the defaulting Party for a period in excess of fourteen (14) calendar days from the date upon which the non-defaulting Party issues notice of default (hereinafter, a "Default Notice") to the defaulting Party, then the default shall constitute a breach of this Agreement. If a Party is in breach of this Agreement, the non-breaching Party may pursue any and all remedies available to it at law or in equity. If CONSULTANT is in breach (whether or not such breach is caused by

CONSULTANT or CONSULTANT's officials, officers, employees, agents, contractors, subcontractors or subconsultants, CITY may, in its sole and absolute discretion (and without obligation), terminate this Agreement immediately upon the issuance written notice of termination on the grounds of breach (a "Breach-Termination Notice") which notice shall specify the effective date of such termination for cause. CITY's ability to terminate this Agreement as provided in this Section shall be in addition to any other remedies CITY may have at law or in equity in the event of breach and shall not be in lieu of such other remedies.

- 5.3 SCOPE OF WAIVER: No waiver of any default or breach under this Agreement shall constitute a waiver of any other default or breach, whether of the same or other covenant, warranty, agreement, term, condition, duty or requirement contained in this Agreement. No waiver, benefit, privilege, or service voluntarily given or performed by a Party shall give the other Party any contractual rights by custom, estoppel, or otherwise.
- 5.4 SURVIVING ARTICLES, SECTIONS AND PROVISIONS: The termination of this Agreement pursuant to any provision of this Article or by normal expiration of its term or any extension thereto shall not operate to terminate any Article, Section or provision contained herein which provides that it shall survive the termination or normal expiration of this Agreement.

VI.

MISCELLANEOUS PROVISIONS

- 6.1 DOCUMENTS & DATA; LICENSING OF INTELLECTUAL PROPERTY: All Documents and Data shall be and remain the property of CITY without restriction or limitation upon their use or dissemination by CITY. For purposes of this Agreement, the term "Documents and Data" means and includes all reports, studies, analyses, correspondence, plans, drawings, designs, renderings, specifications, notes, summaries, strategies, charts, schedules, spreadsheets, calculations, lists, data compilations, documents or other materials developed and/or assembled by or on behalf of CONSULTANT in the performance of this Agreement and fixed in any tangible medium of expression, including but not limited to Documents and Data stored on paper, digitally, magnetically and/or electronically. CONSULTANT shall require all subcontractors and subconsultants working on behalf of CONSULTANT in the performance of this Agreement to agree in writing that CITY shall be granted the same right to copy, use, reuse, disseminate and retain Documents and Data prepared or assembled by any subcontractor or subconsultant as applies to Documents and Data prepared by CONSULTANT in the performance of this Agreement.
- 6.2 CONFIDENTIALITY: All ideas, memoranda, specifications, plans, procedures, drawings, descriptions, computer program data, input recorded data, written information, and other like information either created by or provided to CONSULTANT in connection with the performance of this Agreement shall be held confidentially by CONSULTANT. Such materials shall not, without the prior written consent of CITY, be used by CONSULTANT for any purposes other than the performance of the Work. Nor shall such materials be disclosed to any person or entity not connected with the performance of the Work. Nothing furnished to CONSULTANT which is otherwise known to CONSULTANT or is generally known, or has become known, to the related industry shall be deemed confidential.

CONSULTANT shall not use CITY's name or insignia, photographs, or any publicity pertaining to the Work in any magazine, trade paper, newspaper, television or radio production or other similar medium without the prior written consent of CITY.

- 6.3 **NOTICES:** All notices permitted or required under this Agreement shall be given to the respective Parties at the following addresses, or at such other address as the respective Parties may provide in writing for this purpose:

CONSULTANT:

Evan Brooks Associates, Inc.
 Attn: Hal Suetsugu
 President- Managing Partner
 1030 Arroyo Parkway, Ste. 204
 Pasadena, CA 91105
 Tel: (626) 799-8011
 Fax: (888) 421-8798

CITY:

City of San Fernando
 Attn: Chris Marcarello
 Deputy City Manager/Public Works Director
 117 Macneil Street
 San Fernando, CA 91340
 Tel: (818) 898-1222
 Fax: (818) 361-6728

Such notices shall be deemed effective when (i) personally delivered; (ii) successfully transmitted by facsimile as evidenced by a fax confirmation slip; (iii) when successfully transmitted and received via electronic mail at any of the e-mail addresses listed above; or (iv) when mailed, forty-eight (48) hours after deposit with the United States Postal Service, first class postage prepared and addressed to the Party at its applicable address.

- 6.4 **COOPERATION; FURTHER ACTS:** The Parties shall fully cooperate with one another, and shall take any additional acts or sign any additional documents as is reasonably necessary, appropriate or convenient to achieve the purposes of this Agreement.
- 6.5 **SUBCONTRACTING:** CONSULTANT shall not subcontract any portion of the Work required by this Agreement, except as expressly stated herein, without the prior written approval of CITY. Subcontracts (including without limitation subcontracts with subconsultants), if any, shall contain a provision making them subject to all provisions stipulated in this Agreement, including provisions relating to insurance requirements and indemnification.
- 6.6 **CITY'S RIGHT TO EMPLOY OTHER CONSULTANTS:** CITY reserves the right to employ other consultants in connection with the various projects worked upon by CONSULTANT.
- 6.7 **PROHIBITED INTERESTS:** CONSULTANT warrants, represents and maintains that it has not employed nor retained any company or person, other than a *bona fide* employee working solely for CONSULTANT, to solicit or secure this Agreement. Further, CONSULTANT warrants and represents that it has not paid nor has it agreed to pay any company or person, other than a *bona fide* employee working solely for CONSULTANT, any fee, commission, percentage, brokerage fee, gift or other consideration contingent upon or resulting from the award or making of this Agreement. For breach or violation of this warranty, CITY shall have the right to rescind this Agreement without liability. For the term of this Agreement, no member, officer or employee of CITY, during the term of his or her service with CITY, shall

have any direct interest in this Agreement, or obtain any present or anticipated material benefit arising therefrom.

- 6.8 TIME IS OF THE ESSENCE: Time is of the essence for each and every provision of this Agreement.
- 6.9 FORCE MAJEURE: Any prevention, delay, nonperformance or stoppage due to any of the following causes shall excuse nonperformance for a period equal to such obligations imposed by this Agreement. The causes referred to above are strikes, walkouts, labor disputes, failure of power, irresistible superhuman cause, acts of public enemies of the State or United States, riots, insurrections, civil commotion, inability to obtain labor or material or reasonable substitutes for either, governmental restrictions or regulations or controls (except those reasonably foreseeable in connection with the uses contemplated by this Agreement), casualties not contemplated by insurance provisions of this agreement, or other causes beyond the reasonable control of the party obligated to perform.
- 6.10 GOVERNING LAW; VENUE: This Agreement shall be interpreted and governed according to the laws of the State of California. In the event of litigation between the Parties, venue, without exception, shall be in the Los Angeles County Superior Court of the State of California. If, and only if, applicable law requires that all or part of any such litigation be tried exclusively in federal court, venue, without exception, shall be in the Central District of California located in the City of Los Angeles, California.
- 6.11 ATTORNEY'S FEES: If either Party commences an action against the other Party, either legal, administrative or otherwise, arising out of or in connection with this Agreement, the prevailing Party in such litigation shall be entitled to have and recover from the losing Party reasonable attorney's fees and all other costs of such action.
- 6.12 SUCCESSORS AND ASSIGNS: This Agreement shall be binding on the successors and assigns of the Parties.
- 6.13 NO THIRD PARTY BENEFIT: There are no intended third party beneficiaries of any right or obligation assumed by the Parties. All rights and benefits under this Agreement inure exclusively to the Parties.
- 6.14 CONSTRUCTION OF AGREEMENT: This Agreement shall not be construed in favor of, or against, either Party but shall be construed as if the Parties prepared this Agreement together through a process of negotiation and with the advice of their respective attorneys.
- 6.15 SEVERABILITY: If any portion of this Agreement is declared invalid, illegal, or otherwise unenforceable by a court of competent jurisdiction, the remaining provisions shall continue in full force and effect.
- 6.16 AMENDMENT; MODIFICATION: No amendment, modification, or supplement of this Agreement shall be valid or binding unless executed in writing and signed by both Parties, subject to CITY approval. The requirement for written amendments, modifications, or supplements cannot be waived and any attempted waiver shall be void and invalid.

- 6.17 CAPTIONS: The captions of the various articles, sections and paragraphs are for convenience and ease of reference only, and do not define, limits, augment, or describe the scope, content, or intent of this Agreement.
- 6.18 INCONSISTENCIES OR CONFLICTS: In the event of any conflict or inconsistency between the provisions of this Agreement and any of the exhibits attached hereto, the provisions of this Agreement shall control.
- 6.19 ENTIRE AGREEMENT: This Agreement including all attached exhibits is the entire, complete, final and exclusive expression of the Parties with respect to the matters addressed herein and supersedes all other agreements or understandings, whether oral or written, or entered into between CITY and CONSULTANT prior to the execution of this Agreement. No statements, representations or other agreements, whether oral or written, made by any Party that is not embodied herein shall be valid or binding. No amendment, modification or supplement to this Agreement shall be valid and binding unless in writing and duly executed by the Parties pursuant to Section 6.16, above.
- 6.20 COUNTERPARTS: This Agreement shall be executed in two (2) original counterparts each of which shall be of equal force and effect. One counterpart shall be delivered to CONSULTANT and the other shall be retained by CITY. No handwritten or typewritten amendment, modification or supplement to any one counterparts shall be valid or binding unless made to all three counterparts in conformity with Section 6.16, above.

[SIGNATURE PAGE TO FOLLOW]

AS OF THE DATE FIRST WRITTEN ABOVE, the Parties evidence their agreement to the terms of this Agreement by signing below:

CITY:

City of San Fernando

By: 

Name: BRIAN SAEKI

Title: CITY MANAGER

APPROVED AS TO FORM:

By: 
City Attorney

CONSULTANT:

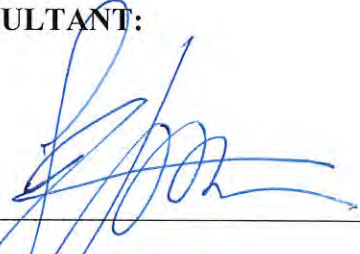
By: 

Print: WAL SUBTUGU

Title: PRESIDENT - MANAGING PARTNER

EXHIBIT "A"**SCOPE OF WORK CHECKLIST**

The scope of work is the official description of the work that is to be completed during the contract. **The scope of work must be consistent with the project timeline.**

The scope of work must:

- Be completed using the FY 2015-16 template provided and in Microsoft Word format.
- List all tasks and sub-tasks using the same title as stated in the project timeline.
- Have task and sub-task numbers in accurate and proper sequencing; consistent with the project timeline.
- List the responsible party for each task and subtask and ensure that it is consistent with the project timeline (i.e. applicant, sub-applicant, or consultant).
- Have a thorough Introduction to describe the project and project area demographics.
- Have a thorough and accurate narrative description of each task and sub-task.
- Include a task for a kick-off meeting with Caltrans at the start of the grant.
- Include a task for procurement of consultants, if consultants are needed.
- Include a task for invoicing.
- Include a task for quarterly reporting to Caltrans.
- Include public participation and services to diverse communities.
- Include project implementation/next steps.
- NOT include environmental, complex design, or engineering work and other ineligible activities.
- List the project deliverable for each task in a table following each task and ensure that it is consistent with the project timeline.

SCOPE OF WORK

City of San Fernando Safe Routes to School Plan

INTRODUCTION:

The City of San Fernando will develop a comprehensive Safe Routes to School (SRTS) plan aimed at increasing the number of children that walk and ride their bicycle to school. The City will work with the school district, individual schools, parents and youth to identify barriers to walking and bicycling to school sites. The collective findings will be compiled into a plan with detailed design recommendations for physical changes to streets, sidewalks and intersections to support safe and active transportation to all the schools.

In 2012, the City of San Fernando had a population of 23,752 of which 93.1 percent is Hispanic. The median household income is lower than the County of Los Angeles at \$48,300 versus \$53,880. The average household size is much larger than the County at 4.0 persons per household versus 3.0 for the County. Twenty-one (21%) percent of San Fernando households have six or more household members. A total of 52.1 percent of the San Fernando population over 25 years old has completed high school or a higher level of education.

RESPONSIBLE PARTIES:

City of San Fernando is the lead applicant for this project. The City will be the grant recipient, execute the contract with Caltrans and the sub-recipients. The City of San Fernando will review grant products, and perform grant administration functions as required. The City will identify staff members to participate in all aspects of the project and provide staff support to meet the local in-kind match requirement. City staff will select a design and planning consultant, through its existing on-call consultant bench, to develop conceptual and planning drawings to be added to the design and charrette presentation for effective visualization. The selected consultant will provide GIS, conceptual renderings, planning drawings, technical consulting, general infrastructure guidance and expertise.

The California Center for Public Health Advocacy (CCPHA) is the sub-recipient for this project. CCPHA is a nonprofit 501(c)3 organization that has been working in the San Gabriel Valley region since 1999 in creating policies for healthier community living. CCPHA has been the lead organization for multiple regional initiatives, including, Healthy Kids Healthy Communities (HKHC), First 5, LA RENEW, and the Healthy Eating Active Communities (HEAC) project. CCPHA will lead all community participation and engagement strategies of the grant including ensuring a well-established resident led safe routes advisory group to expand communication with the City on all transportation issues affecting safety and quality of life.

OVERALL PROJECT OBJECTIVES:

The primary objective will be to develop recommendations for infrastructure changes to improve safe walking and bicycling to all 11 schools in and around the 2.4 square miles of the City of San Fernando. The plan will also include recommendations for non-infrastructure programs such as “walking school buses” or “rewards programs” that make use of the other SRTS “E”s, namely Encouragement, Education and Enforcement. These programs can be implemented in the short term to motivate parents and children to walk and ride a bicycle to school and have been proven to

be very successful in other cities in the nation. This project will benefit the underprivileged and under-represented minority population who have had a perceived lack of confidence in the safety of their streets and neighborhoods.

TASK 1. PROJECT MANAGEMENT AND COORDINATION

Task 1.1: Project Kickoff Meeting

San Fernando City staff will conduct a kick-off meeting with Caltrans staff to discuss scope of work, grant procedures and project expectations including invoicing, quarterly progress reports, and other relevant project information.

- Responsible Party: City of San Fernando

Task 1.2: Contracting with Sub-Applicants

City staff will prepare a subcontract with the California Center for Public Health Advocacy (CCPHA), the sub-applicant on this grant who will work in partnership with the selected consultant and the City to coordinate all aspects of the community engagement for the project.

- Responsible Party: City of San Fernando

Task 1.3: Project Team Kick-Off Meeting

Kick-off meeting with city staff, selected consultant and CCPHA to discuss scope of work, timeline/budget, review tasks and objectives, and expectations of deliverables. Project team will prepare an action plan that will coordinate outreach efforts and establish a coordinated timeline. City staff will provide consultant with available information on existing conditions for the project areas, including area photos, traffic volumes, crash data, regional transportation plans, state route planning and construction plans, aerial and base maps, General Plan and other policy documents, development standards and regulations, and other relevant studies.

- Responsible Party: City, Consultant, CCPHA

Task 1.4: Staff Coordination – Team Meetings

Conduct monthly team coordination meetings with consultant, city staff and CCPHA to maintain good communication throughout the project, provide updates on deliverables, and ensure project is on time and within budget. City staff will collect all pertinent deliverables for the quarter to submit with quarterly report to Caltrans. Other discussions will be plan development, recommendations and next steps.

- Responsible Party: City, Consultant, CCPHA

Task	Deliverables
1.1	Copy of agenda, meeting summary and final scope of work
1.2	Copy of executed subcontract with CCPHA
1.3	Copy of agenda, meeting summary, outreach action plan, sign-in sheet & list of collected data
1.4	Copy of agendas, meeting summaries and sign-in sheet

TASK 2: PUBLIC OUTRTEACH AND PARTICIPATION

Description: A series of planning presentations and activities are scheduled for this community-based planning effort and is expected to span over a three-month period. The purpose of the presentation and activities will be to work with community residents, school officials and City public safety staff to establish guiding principles, identify problems, and discuss proposed strategies to increase walking and bicycling to schools and local businesses. Strategies will include street and intersection design concepts that improve safety for walking and bicycling, changes to the drop-off and pick-up procedures at the school to reduce congestion and potential for collisions around the school, and the full range of non-infrastructure programs (including education, encouragement, enforcement and evaluation) that can support more walking and bicycling. The City will work with the selected consultant to coordinate all presentation materials and develop planning activities (such as charrettes, concept renderings and lessons learned programs from other successful agencies and bring in CCPHA to intergrade the attendees comments and concerns into the planning design for all transportation modes. To prepare community members to participate in these planning activities, CCPHA will organize a series of educational workshops prior to and during these events.

Task 2.1: Assemble Community Advisory Committee

CCPHA, in coordination with consultant, city staff, and the Transportation and Safety Commission, will assemble a Community Advisory Committee to provide input as the project moves forward. The Advisory Committee will include City staff, local school staff, representatives from service organizations, faith-based community, businesses, neighborhood leaders, youth, and other interest groups that reflect the demographics and perspectives of the community. The Community Advisory Committee of 8 to 12 representatives from agencies and the community will be consulted throughout the project and serve as a sounding board. The Community Advisory Committee will assist in scheduling, coordinating and participating in the mini-charrettes that will be held throughout the community during the duration of the project. The Committee will work to identify additional community leaders, determine strategies to engage all segments of the community, maximize community participation, assist with school site observations, develop infrastructure recommendations to improve safe walking and bicycling to schools, and advocate for the project.

- Responsible Party: CCPHA and Consultant

Task 2.2: Community Advisory Committee Kick-off Meeting

CCPHA will facilitate a kick-off meeting with the Community Advisory Committee to discuss the project, scope of work, community outreach action plan, and project timeline. The Committee's role will be identified along with their expectations. A brief presentation of existing conditions and an overview of Complete Streets will be provided. The Committee will discuss the schedule for the upcoming mini-charrettes and members will be assigned selected schools for their observation assignment. They will develop a list of key stakeholders to invite, identifying problem areas to study, and identify strategies for engaging residents, in particular underrepresented residents.

- Responsible Party: CCPHA

Task 2.3: Pre-Charrette Visit

Consultant will conduct a one-day pre-charrette visit to coincide with the first Community Advisory Committee meeting (see Task 2.1) to meet with the project partners and selected stakeholders, and tour and photograph the areas to assess existing conditions.

- Responsible Party: Consultant

Task 2.4: Pre-Charrette Community Workshops

CCPHA, in coordination with city staff, will organize two (2) educational and awareness workshops for the residents, businesses, school officials and public safety staff, who were identified by the Advisory Committee, to provide them with the information and skills they need to help facilitate the mini-charrettes. The workshops will entail leadership training exercises to develop the skills they need to perform the walkability and bikability audits, use of assessment tools and how to develop a Safe Routes to School Plans. The 90-minute workshops will be offered in English and Spanish, including written materials and participant activities.

- Responsible Party: CCPHA and city staff

Task 2.5: Community Charrettes and Assessment Tours

City consultant and CCPHA will conduct three (3) two-day neighborhood charrettes and tours. Each charrette will be conducted either at school or city facilities and will address issues at all elementary, middle and high schools. Each charrette and tour will consist of the following events:

- Short tour and observation of the morning arrival of students at the school.
- Morning workshop with parents, school and public safety staff and police to discuss the key elements of Safe Streets and Safe Routes to School programs.
- Walkability and Bike-ability Audits around the school to identify the challenges children face in walking or bicycling to school.
- Design table exercise after Walkability and Bike-ability Audits where parents, business owners, city and school staff and neighbors will be able to draw or write their comments, concerns and ideas on aerial photographs of the area around the school.
- Activity with a 5th (elementary school aged) and 6th (middle school aged) grade class that asks children to draw their route to school and what they think of the safety of walking and biking to school. Also, to discuss the perceived dangers along Huntington Drive and their suggested improvements.
- Present at School Board, Traffic Commission and Parents Teachers Association meetings to present the recommendations.

- **Responsible Party:** City staff, Consultant and CCPHA

Task 2.6: Produce and Distribute Outreach Material

CCPHA will produce Announcements/Flyers/Mailers/Posters publicizing the meetings for community-wide distribution. Flyers will be produced in English and Spanish. The City, local businesses, community based organizations, school based liaisons, faith-based and service organizations, will be asked to distribute flyers and information about the meetings through their communication networks. Elementary, Middle and High Schools will be asked to send flyers home with their students. CCPHA will distribute flyers to neighborhood residents through community churches and other identified channels. A communications plan and media outreach materials will be developed, which may include press releases/alerts and project fact sheet(s) for distribution and outreach to local media. The project partners will work on setting up community wide signs or banners announcing events. Information will be posted on the City and School District website, community marquee and local paper.

- Responsible Party: CCPHA

Task	Deliverable
2.1	Outreach list, e-mail correspondence and Advisory Committee roster
2.2	Meeting Agenda, e-mail correspondence, PowerPoint presentation, sign-in sheet, meeting summary with outcomes and next steps.
2.3	Assessment of projects area, site photos and preliminary summary of tour
2.4	Meeting Agenda, e-mail correspondence, PowerPoint presentation, fact sheet,

	promotional materials, sign-in sheet, meeting summary with outcomes and next steps.
2.5	Maps, assessment/observation tools, agenda, e-mail correspondence, PowerPoint presentation, fact sheet, promotional materials, sign-in sheet, summary of process and results, photos of audits and parent workshop.
2.6	Announcements/Flyers/Mailers/Posters/distribution list

TASK 3: PREPARATION OF SAFE ROUTES TO SCHOOL PLAN

Task 3.1: Prepare Base Maps

Consultant will prepare all base maps for assessment, analysis and design work to be used for all community meetings and design charrettes.

- Responsible Party: Consultant

Task 3.2: Review of Data Collection and Existing Conditions

Consultant will review and analyze all data collected from the City. Data may include: existing conditions for project areas, area photos, traffic volumes, crash data, regional transportation plans, planning and construction plans, CIP projects, aerials and base maps, general plan and other policy documents, development standards and regulations and other relevant studies.

- Responsible Party: Consultant

Task 3.3: Plan Outline

After the mini-charrettes the consultant team will prepare an outline of the Safe Routes to School Plan and a list of any additional questions, concerns or critical/controversial issues that might have emerged during or after the charrettes. This outline will be circulated to select stakeholders, including school district and city staff and the Advisory Committee for comment.

- Responsible Party: Consultant

Task 3.4: Preparation of Administrative Draft Plan

Within two to three months after the planning and charrette workshops, the project team will prepare an administrative draft. The plan will include recommendations to improve safety conditions for walking and bicycling to all elementary, middle and high schools. The plan will also include conceptual designs, recommendations and development standards for improved road safety and operations, pedestrian, bicycle and transit facilities, and enhanced safety features and streetscapes. The plan will also contain a record of the planning and charrette process, proposed timing and prioritization for implementation of the recommendations, and potential funding sources.

- Responsible Party: Consultant

Task 3.5: Draft Plan Comments

City staff and consultants will circulate the draft plan to City and School District staff, City public safety and Police, Caltrans staff and the Advisory Committee for feedback. Consultant will collect and review all comments and provide a comprehensive set of consistent comments to the City and project team.

- Responsible Party: Consultant

Task	Deliverable
3.1	Copies of base maps
3.2	Copies of all data collected and summary of analysis
3.3	Copy of Outline
3.4	Administrative Draft – Safe Routes to School Plan
3.5	Matrix of all comments collected

Task 4: ADOPTION OF SAFE ROUTES TO SCHOOL PLAN

Task 4.1: Advisory Committee/Community Meeting

The consultant will facilitate a final Community Meeting where they will present the draft Plan and provide an overview of the completed project. Final recommendations will be received and incorporated into the final document to be presented to the Planning Commission and City Council. Additionally, staff will work with selected community members to attend the public hearings to provide testimony of their involvement and speak in favor of the project.

- Responsible Party: Consultant, CCPHA, City Staff

Task 4.2: Planning Commission Meeting

Consultant and city staff will present the final study for Planning Commission consideration and recommendation of approval to the City Council. This meeting will be noticed as a public hearing and the public will have an opportunity to comment and speak in support of the project.

- Responsible Party: Consultant and City Staff

Task 4.3: City Council Meeting

The Safe Routes to School Plan will be considered by the City Council for approval and adoption. This meeting will be noticed as a public hearing and the public will have an opportunity to comment and speak in support of the project.

- Responsible Party: Consultant and City Staff

Task	Deliverable
4.1	Agenda, copy of presentation, summary of outcomes and next steps, sign-in sheet, e-mail correspondence and copies of promotional material(s).
4.2	Planning Commission Agenda, copies of promotional material(s), presentation, and copy of commission minutes
4.3	City Council Agenda, copies of promotional material(s), presentation, and copy of City council minutes

TASK 5: PROJECT MANAGEMENT AND ADMINISTRATION

Task 5.1: Project Administration

Project administration will occur between the consultant and the City of San Fernando. This will consist of weekly teleconferences and monthly progress reports and invoices. This process will ensure proper documentation of expenditures and timely use of funds. Monthly invoices will be submitted to the Caltrans project manager for processing and reimbursement.

- Responsible Party: Consultant and City Staff

Task 5.2: Quarterly Reports

Monitor ongoing progress and prepare quarterly reports, identifying milestones. SCAG in coordination with San Fernando staff will submit quarterly reports to Caltrans district staff providing a summary of project progress and grant/local match/in-kind expenditures.

- Responsible Party: Consultant and City Staff

Task	Deliverable
5.1	Monthly progress reports and invoices
5.2	Quarterly progress reports and invoices

**ATTACHMENT "C"
CONTRACT NO. 1807**



2015

PROFESSIONAL SERVICES AGREEMENT

Outreach and Planning Services to Develop a Comprehensive Safe Routes to School Plan for the City of San Fernando
California Center for Public Health Advocacy

THIS 2013 PROFESSIONAL SERVICES AGREEMENT ("Agreement") is entered into this 7th day of December 2015 (hereinafter, the "Effective Date"), by and between the CITY OF SAN FERNANDO, a municipal corporation and general law city ("CITY") and California Center for Public Health Advocacy (hereinafter, "CONSULTANT"). The capitalized term "Parties" shall be a collective reference to both CITY and CONSULTANT. The capitalized term "Party" shall refer to either CITY or CONSULTANT interchangeably as appropriate.

RECITALS

THIS AGREEMENT is made and entered into with respect to the following facts:

WHEREAS, CITY, pursuant to California Government Code Sections 37103 and 53060, is authorized and empowered to contract with any specially trained and experienced firm or corporation for special services and advice on financial, economic, accounting, engineering, legal or administrative matters; and

WHEREAS, CITY's in-house personnel are not able to provide the types of specialized consulting services required under this engagement; and

WHEREAS, CITY require the performance of **outreach and planning** services in connection with the **development of a comprehensive Safe Routes to School Plan for the City of San Fernando**; and

WHEREAS, CONSULTANT represents that it is fully qualified to perform such professional services by virtue of its experience and the training, education and expertise of its principals, employees and subcontractors; and

WHEREAS, the execution of this Agreement was approved by the City Council in accordance with the CITY's procurement and purchasing procedures at the City Council's meeting of December 7, 2015 under Agenda Item [REDACTED]; and

WHEREAS, CONSULTANT further represents that it is willing to accept responsibility for performing such services in accordance with the terms and conditions set forth in this Agreement.

NOW, THEREFORE, FOR AND IN CONSIDERATION OF THE MUTUAL COVENANTS AND CONDITIONS HEREIN CONTAINED, CITY AND CONSULTANT AGREE AS FOLLOWS:

I.

SCOPE AND PROSECUTION OF WORK; COMPENSAITON

1.1 SCOPE OF WORK: Subject to the terms and conditions set forth in this Agreement and all exhibits attached and incorporated hereto, CONSULTANT agrees to perform the services and tasks set forth in that certain proposal entitled **Outreach and Planning Services to Develop a Comprehensive Safe Routes to School Plan for the City of San Fernando** and dated as of [REDACTED] 20[REDACTED] which is attached and incorporated hereto **Exhibit "A"**

(hereinafter the "Scope of Work"). CONSULTANT further agrees to furnish to CITY all labor, materials, tools, supplies, equipment, services, tasks and incidental and customary work necessary to competently perform and timely complete the services and tasks set forth in the Scope of Work. For the purposes of this Agreement the aforementioned services and tasks set forth in the Scope of Work shall hereinafter be referred to generally by the capitalized term "Work." The Work is inclusive of those tasks that may be identified as being optional under the Scope of Work and such optional work shall not constitute Extra Work under Section 1.5 of this Agreement, below. Neither CONSULTANT nor anyone acting on CONSULTANT's behalf shall commence with the performance of the Work or any other related tasks until CITY issues a written notice to proceed (hereinafter, the "Notice to Proceed").

1.2 TERM:

- A. This Agreement shall have a term of two (2) years commencing from the **Effective Date** (hereinafter, the "Initial Term").
- B. This Agreement may be extended subject to the same terms and conditions set forth herein for a maximum of two (2) six (6) **month** extension terms, in the sole and absolute discretion of CITY, provided CITY issues written notice of its intent to so extend the Agreement no less than thirty (30) calendar days prior to the expiration of the Initial Term or any subsequent extension term. Nothing in this subsection shall operate to prohibit or otherwise restrict CITY right to terminate this Agreement at any time for convenience or for cause as provided herein.]
- C. Nothing in this Section shall operate to prohibit or otherwise restrict the CITY's ability to terminate this Agreement at any time for convenience or for cause.

1.3 COMPENSATION AND COMPENSATION CONTROLS:

- A. CONSULTANT shall perform and complete all of the services and tasks set forth under the Scope of Work at the rates of compensation set forth in that certain compensation schedule set forth under **[page XX/Section XX]** of the Scope of Work under the heading "**Fees**" (hereinafter, the "Compensation Schedule"). CONSULTANT shall also receive reimbursement for those pass-through costs and expenses specifically identified in the Compensation Schedule as being reimbursable pass-through costs, except that any such costs which are anticipated to be in excess of \$500.00 shall require the prior written approval of the General Manager or designee before they are incurred. For purposes of this Agreement, those pass-through costs or expenses identified as being reimbursable under the Compensation Schedule may hereinafter be referred to as "Reimbursable Costs". CONSULTANT shall provide copies of receipts and invoices corroborating all costs or expenses, including Reimbursable Costs, indicated in CONSULTANT's monthly invoice or statement. CITY shall be under no obligation to reimburse CONSULTANT for unsubstantiated costs or expenses.
- B. Subsection (A) of this Section notwithstanding, in no event may CONSULTANT's total compensation for the performance and completion of the Work exceed the aggregate sum of fifty-seven thousand one hundred fifty Dollars (\$57,150) during the entire Initial Term of the Agreement or during any single extension term ("Contract Price).
- C. In so far as CONSULTANT seeks reimbursement for costs and expenses other than those that qualify as Reimbursable Expenses, such costs or expenses shall be deducted against the **Not-to-Exceed Sum**.

1.4 PAYMENT OF COMPENSATION:

- A. CITY shall compensate CONSULTANT on a monthly basis as tasks are performed and the Work is completed to the reasonable satisfaction of CITY. Following the conclusion of each month during the Initial Term of this Agreement or any extension term, CONSULTANT shall submit to

CITY a monthly itemized invoice or statement identifying the tasks performed, hours of service rendered and reimbursable pass-through costs incurred by CONSULTANT and its various employees during the recently concluded month.

- B. Within thirty (30) calendar days of receipt of each invoice, CITY shall notify CONSULTANT in writing of any disputed charges, costs or expenses included in the invoice. Within forty-five (45) calendar days of receipt of each invoice, CITY shall pay all undisputed charges, costs and expenses indicated in CONSULTANT's monthly invoice.
- C. CITY shall not withhold applicable taxes or other authorized deductions from payments made to CONSULTANT.

1.5 EXTRA WORK; COMPENSATION FOR EXTRA WORK:

- A. At any time during the term of this Agreement, CITY may request that CONSULTANT perform Extra Work. For the purposes of this Agreement, the term "Extra Work" means any additional work, services or tasks not set forth in the Scope of Work but later determined by CITY to be necessary. CONSULTANT shall not undertake nor shall CONSULTANT be entitled to compensation for Extra Work without the prior written authorization of the CITY. Extra Work does not include any labor, materials, tools, supplies, equipment, services, tasks or incidental and customary work undertaken to competently perform and timely complete the Work and related tasks set forth in the Scope of Work.
- B. Payments for any Extra Work shall be made to CONSULTANT on a time-and-materials basis using CONSULTANT's standard fee schedule.

1.6 ACCOUNTING RECORDS: CONSULTANT shall maintain complete and accurate records with respect to all matters covered under this Agreement for a period of three (3) years after the expiration or termination of this Agreement. CITY shall have the right to access and examine such records, without charge, during normal business hours. CITY shall further have the right to audit such records, to make transcripts therefrom and to inspect all program data, documents, proceedings, and activities.

1.7 ABANDONMENT BY CONSULTANT: In the event CONSULTANT ceases to perform the Work agreed to under this Agreement or otherwise abandons the undertaking contemplated herein prior to the expiration of this Agreement or prior to completion of any or all tasks set forth in the Scope of Work, CONSULTANT shall deliver to CITY immediately and without delay, all materials, records and other work product prepared or obtained by CONSULTANT in the performance of this Agreement. Furthermore, CONSULTANT shall only be compensated for the reasonable value of the services, tasks and other work performed up to the time of cessation or abandonment, less a deduction for any damages, costs or additional expenses which CITY may incur as a result of CONSULTANT's cessation or abandonment.

II.

PERFORMANCE OF AGREEMENT

2.1 CITY'S REPRESENTATIVES: The CITY hereby designates **Deputy City Manager** (hereinafter, the "CITY Representatives") to act as its representatives for the performance of this Agreement. The CITY Representatives or their designee shall act on behalf of the CITY for all purposes under this Agreement. CONSULTANT shall not accept directions or orders from any person other than the CITY Representatives or their designee.

2.2 CONSULTANT'S REPRESENTATIVE: CONSULTANT hereby designates **[Insert Name and Title of Person who will be Representing Consultant in the Performance and Administration of this Agreement]** to act as its representative for the performance of this Agreement (hereinafter,

“Consultant’s Representative”). CONSULTANT’s Representative shall have full authority to represent and act on behalf of the CONSULTANT for all purposes under this Agreement. Consultant’s Representative or his designee shall supervise and direct the performance of the Work, using his/her best skill and attention, and shall be responsible for all means, methods, techniques, sequences and procedures and for the satisfactory coordination of all portions of the Work under this Agreement. Notice to the Consultant’s Representative shall constitute notice to CONSULTANT.

2.3 COORDINATION OF SERVICE; CONFORMANCE WITH REQUIREMENTS: CONSULTANT agrees to work closely with CITY staff in the performance of the Work and this Agreement and shall be available to CITY staff and the CITY Representatives at all reasonable times. All work prepared by CONSULTANT shall be subject to inspection and approval by CITY Representatives or their designees.

2.4 STANDARD OF CARE; PERFORMANCE OF EMPLOYEES: CONSULTANT represents, acknowledges and agrees to the following:

- A. CONSULTANT shall perform all work skillfully, competently and to the highest standards applicable to the CONSULTANT’s profession;
- B. CONSULTANT shall perform all work in a manner reasonably satisfactory to the CITY;
- C. CONSULTANT shall comply with all applicable federal, state and local laws and regulations, including the conflict of interest provisions of Government Code Section 1090 and the Political Reform Act (Government Code Section 81000 *et seq.*);
- D. CONSULTANT understands the nature and scope of the Work to be performed under this Agreement as well as any and all schedules of performance;
- E. All of CONSULTANT’s employees and agents (including but not limited to CONSULTANT’s subcontractors and subconsultants) possess sufficient skill, knowledge, training and experience to perform those services and tasks assigned to them by CONSULTANT; and
- F. All of CONSULTANT’s employees and agents (including but not limited to CONSULTANT’s subcontractors and subconsultants) possess all licenses, permits, certificates, qualifications and approvals of whatever nature that are legally required to perform the tasks and services contemplated under this Agreement and all such licenses, permits, certificates, qualifications and approvals shall be maintained throughout the term of this Agreement.

The Parties acknowledge and agree that CONSULTANT shall perform, at CONSULTANT’s own cost and expense and without any reimbursement from CITY, any services necessary to correct any errors or omissions caused by CONSULTANT’s failure to comply with the standard of care set forth under this Section or by any like failure on the part of CONSULTANT’s employees, agents, contractors, subcontractors and subconsultants. Such effort by CONSULTANT to correct any errors or omissions shall be commenced immediately upon their discovery by either Party and shall be completed within seven (7) calendar days from the date of discovery or such other extended period of time authorized by the CITY Representatives in writing and absolute discretion. The Parties acknowledge and agree that CITY’s acceptance of any work performed by CONSULTANT or on CONSULTANT’s behalf shall not constitute a release of any deficiency or delay in performance. The Parties further acknowledge, understand and agree that CITY has relied upon the foregoing representations of CONSULTANT, including but not limited to the representation that CONSULTANT possesses the skills, training, knowledge and experience necessary to perform the Work in a skillful and competent manner equivalent to, the standard of performance generally recognized as being employed by professionals performing the same type of work and services in the State of California.

2.5 ASSIGNMENT: The skills, training, knowledge and experience of CONSULTANT are material to CITY’s willingness to enter into this Agreement. Accordingly, CITY has an interest in the

qualifications and capabilities of the person(s) who will perform the services and tasks to be undertaken by CONSULTANT or on behalf of CONSULTANT in the performance of this Agreement. In recognition of this interest, CONSULTANT agrees that it shall not assign or transfer, either directly or indirectly or by operation of law, this Agreement or the performance of any of CONSULTANT's duties or obligations under this Agreement without the prior written consent of the CITY. In the absence of CITY's prior written consent, any attempted assignment or transfer shall be ineffective, null and void and shall constitute a material breach of this Agreement.

- 2.6 CONTROL AND PAYMENT OF SUBORDINATES: The Work shall be performed by CONSULTANT or under CONSULTANT's strict supervision. CONSULTANT will determine the means, methods and details of performing the Work subject to the requirements of this Agreement. CITY retains CONSULTANT on an independent contractor basis and not as an employee. CONSULTANT reserves the right to perform similar or different services for others during the term of this Agreement, provided such work does not unduly interfere with CONSULTANT's competent performance under this Agreement or result in the unauthorized disclosure of CITY's confidential or proprietary information. Any additional personnel performing the Work under this Agreement on behalf of CONSULTANT are not employees of CITY and shall at all times be under CONSULTANT's exclusive direction and control. CONSULTANT shall pay all wages, salaries and other amounts due such personnel and shall assume responsibility for all benefits, payroll taxes, social security and Medicare payments and the like. CONSULTANT shall be responsible for all reports and obligations respecting such additional personnel, including, but not limited to: social security taxes, income tax withholding, unemployment insurance, disability insurance, workers' compensation insurance and the like.
- 2.7 REMOVAL OF EMPLOYEE OR AGENTS: If any of CONSULTANT's officers, employees, agents, contractors, subcontractors or subconsultants is determined by the CITY Representatives to be uncooperative, incompetent, a threat to the adequate or timely performance of the tasks assigned to CONSULTANT, a threat to persons or property, or if any of CONSULTANT's officers, employees, agents, contractors, subcontractors or subconsultants fail or refuse to perform the work in a manner acceptable to the CITY such officer, employee, agent, contractor, subcontractor or subconsultant shall be promptly removed by CONSULTANT and shall not be re-assigned to perform any of the work.
- 2.8 COMPLIANCE WITH LAWS: CONSULTANT shall keep itself fully informed of and in compliance with all applicable laws, statutes, codes, rules, regulations and ordinances of the federal government of the United States of America, the State of California, the County of Los Angeles, and any other local governmental entity to the extent such laws, statutes, codes, rules, regulations or ordinances governing or affecting the performance of the Work.
- 2.9 SAFETY: CONSULTANT shall perform its work so as to avoid injury or damage to any person or property. In performing the Work, CONSULTANT shall at all times be in compliance with all applicable local, state and federal laws, rules and regulations, and shall exercise all necessary precautions for the safety of employees appropriate to the nature of the Work and the conditions under which any work is to be performed.
- 2.10. NON-DISCRIMINATION: In the performance of this Agreement, CONSULTANT shall not discriminate against any employee, subcontractor, subconsultant, or applicant for employment because of race, color, creed, religion, sex, marital status, sexual orientation, national origin, ancestry, age, physical or mental disability or medical condition.
- 2.11. INDEPENDENT CONTRACTOR: The Parties acknowledge, understand and agree that CONSULTANT and all persons retained or employed by CONSULTANT are, and shall at all times remain, wholly independent contractors and are not officials, officers, employees, departments or subdivisions of CITY. CONSULTANT shall be solely responsible for the supervision of its employees, agents, contractors, subcontractors and subconsultants and for the negligent acts and/or omissions of the same. All persons retained or employed by CONSULTANT shall have no authority, express or implied, to bind CITY in any manner, nor to incur any obligation, debt or liability of any kind on behalf

of, or against, CITY, whether by contract or otherwise, unless such authority is expressly conferred to CONSULTANT under this Agreement or is otherwise expressly conferred by CITY in writing.

III. INSURANCE

- 3.1 DUTY TO PROCURE AND MAINTAIN INSURANCE: As more specifically set forth below under this Article, CONSULTANT agrees that it shall procure and maintain throughout the Initial Term of this Agreement and any extension term (or for such extended period of time as may be required under this Article) insurance against claims for death or injuries to persons or damages to property that may arise from or in connection with CONSULTANT's performance of this Agreement. CONSULTANT shall also procure and maintain such other types of insurance as may be required under this Article, below. CITY shall not, and shall be under no obligation to, issue a Notice to Proceed until CONSULTANT has provided evidence satisfactory to CITY that it has procured all insurance required under this Article.
- 3.2 REQUIRED COVERAGES: CONSULTANT agrees that it shall procure and maintain the following insurance coverage, at its own expense, for the duration for this Agreement or any extended period set forth herein:
- A. Commercial General Liability Insurance: CONSULTANT shall procure and maintain Commercial General Liability Insurance ("CGL Coverage") as broad as Insurance Services Office Commercial General Liability coverage (occurrence Form CG 0001 or equivalent). Such CGL Coverage shall have minimum limits of no less than One Million Dollars (\$1,000,000.00) per occurrence for bodily injury, personal injury, property damage, operations, products and completed operations, and contractual liability and Two Million Dollars (\$2,000,000.00) in the aggregate.
 - B. Automobile Liability Insurance: CONSULTANT shall procure and maintain Automobile Liability Insurance as broad as Insurance Services Office Form Number CA 0001 covering Automobile Liability, Code 1 (any auto). Such Automobile Liability Insurance shall have minimum limits of no less than One Million Dollars (\$1,000,000.00) per accident for bodily injury and property damage.
 - C. Workers' Compensation Insurance/ Employer's Liability Insurance: CONSULTANT shall procure and maintain Workers' Compensation Insurance affording coverage at least as broad as that required by the State of California with Employer's Liability Insurance with minimum limits of no less than One Million Dollars (\$1,000,000.00) per accident for bodily injury or disease. The Workers' Compensation insurer shall also agree to waive all rights of subrogation against CITY, the City Council and CITY's elected and appointed officials, officers, employees, agents and volunteers for losses paid under the terms of the insurance policy.
 - D. Professional Liability Insurance: For the full term of this Agreement and for a period of three (3) years thereafter, CONSULTANT shall procure and maintain Errors and Omissions Liability Insurance appropriate to CONSULTANT's profession. Such coverage shall have minimum limits of no less than One Million Dollars (\$1,000,000.00) per claim and shall be endorsed to include contractual liability.
- 3.3 ADDITIONAL INSURED REQUIREMENTS: The CGL Coverage and the Automobile Liability Insurance shall contain an endorsement naming the CITY, the City Council and CITY's elected and appointed officials, officers, employees, agents and volunteers as additional insureds.
- 3.4 REQUIRED CARRIER RATING: All varieties of insurance required under this Agreement shall be procured from insurers licensed in the State of California and authorized to issue policies directly to California insureds. Except as otherwise provided elsewhere under this Article, all required insurance shall be procured from insurers, who according to the latest edition of the Best's Insurance Guide have an A.M. Best's rating of no less than A:VII. CITY may also accept policies procured by

insurance carriers with a Standard & Poor's rating of no less than BBB according to the latest published edition the Standard & Poor's rating guide. As to Workers' Compensation Insurance/ Employer's Liability Insurance, the CITY Representatives are authorized to authorize lower ratings than those set forth in this Section.

- 3.5 PRIMACY OF CONSULTANT'S INSURANCE: All policies of insurance provided by CONSULTANT shall be primary to any coverage available to CITY, the City Council and CITY's elected and appointed officials, officers, employees, agents and volunteers. Any insurance or self-insurance maintained by CITY, the City Council and CITY's elected and appointed officials, officers, employees, agents and volunteers shall be in excess of CONSULTANT's insurance and shall not contribute with it.
- 3.6 WAIVER OF SUBROGATION: All insurance coverage provided pursuant to this Agreement shall not prohibit CONSULTANT or CONSULTANT's officers, employees, agents, subcontractors or subconsultants from waiving the right of subrogation prior to a loss. CONSULTANT hereby waives all rights of subrogation against CITY.
- 3.7 VERIFICATION OF COVERAGE: CONSULTANT acknowledges, understands and agrees that CITY's ability to verify the procurement and maintenance of the insurance required under this Article is critical to safeguarding the CITY's financial well-being. Accordingly, CONSULTANT warrants, represents and agrees that it shall furnish CITY with original certificates of insurance and endorsements evidencing the coverage required under this Article on forms satisfactory to CITY in its sole and absolute discretion. **The certificates of insurance and endorsements for each insurance policy shall be signed by a person authorized by that insurer to bind coverage on its behalf, and shall be on forms provided by the CITY if requested.** All certificates of insurance and endorsements shall be received and approved by CITY as a condition precedent to CONSULTANT's commencement of any work or any of the Work. Upon CITY's written request, CONSULTANT shall also provide CITY with certified copies of all required insurance policies as a condition precedent to the commencement of any work or any of the Work. CITY shall not, and shall be under no obligation to, issue a Notice to Proceed until CONSULTANT fully complies with this Section. The requirements of this Section cannot be waived and any attempted waiver shall be void, invalid and non-binding upon CITY.
- 3.8 FAILURE TO ADHERE TO INSURANCE PROVISIONS: In addition to any other remedies CITY may have under this Agreement or at law or in equity, if CONSULTANT fails to comply with any of the requirements set forth in this Article, CITY may, but shall not be obligated to: (i) Order CONSULTANT to stop any and all work under this Agreement or withhold any payment, which becomes due to CONSULTANT hereunder, or both stop work and withhold any payment, until CONSULTANT demonstrates compliance with the requirements hereof; or (ii) terminate this Agreement. CITY's exercise of any of the foregoing remedies, shall be in addition to any other remedies CITY may have and is not the exclusive remedy for CONSULTANT's failure to comply with the insurance requirements set forth under this Article.
- 3.9 SUBCONTRACTORS INSURANCE COVERAGE: CONSULTANT shall include all persons and entities performing work on its behalf as insureds (including all contractors, subcontractors and subconsultants) or, in the alternative, shall furnish separate certificates of insurance and endorsements for each such persons or entities evidencing their independent procurement of insurance. All coverages for such persons or entities shall be identical to the requirements imposed upon CONSULTANT under this Article.
- 3.10 NO LIMITATION ON LIABILITY: CONSULTANT's procurement of insurance shall not be construed as a limitation of CONSULTANT's liability or as full performance of CONSULTANT's indemnification duties set forth under Article V of this Agreement.

IV.
INDEMNIFICATION

4.1 The Parties agree that City and City's engineer, elected and appointed officials, officers, employees, agents and volunteers (hereinafter, the "City Indemnitees") should, to the fullest extent permitted by law, be protected from any and all loss, injury, damage, claim, lawsuit, cost, attorneys' fees, litigation costs, or any other cost arising out of or in any way related to the performance of this Agreement. Accordingly, the provisions of this indemnity provision are intended by the Parties to be interpreted and construed to provide the City Indemnitees with the fullest protection possible under the law. Consultant acknowledges that City would not enter into this Agreement in the absence of Consultant's commitment to indemnify, defend and protect the City as set forth herein.

4.2 To the fullest extent permitted by law, the Consultant shall (i) immediately defend and (ii) indemnify and hold harmless the City and its engineer, elected and appointed officials, officers, agents, employees, attorneys, servants, volunteers, successors and assigns from and against any and all liabilities, regardless of nature or type that arise out of, pertain to, or relate to the negligence, recklessness, or willful misconduct of the Consultant, or its officers, employees, servants, agents, subcontractors, volunteers or any other person or entity involved by, for, with or on behalf of Consultant in the performance of this Agreement. The parties understand and agree that the duty of Consultant to indemnify and hold harmless includes the duty to defend as set forth in Section 2778 of the California Civil Code. Liabilities subject to the duties to defend and indemnify include, without limitation, all claims, losses, damages, penalties, fines, and judgments; associated investigation and administrative expenses; defense costs, including but not limited to reasonable attorneys' fees incurred by legal counsel of City's choosing; court costs; and costs of alternative dispute resolution. The Consultant's obligation to indemnify applies unless it is finally adjudicated that the liability was caused by the sole active negligence or sole willful misconduct of an indemnified party. If it is finally adjudicated that liability is caused by the comparative active negligence or willful misconduct of an indemnified party, then Consultant's indemnification obligation shall be reduced in proportion to the established comparative liability.

4.3 The duty to defend is a separate and distinct obligation from Consultant's duty to indemnify. Consultant shall be obligated to defend, in all legal, equitable, administrative, or special proceedings, with counsel approved by the City, City and its engineer, elected and appointed officials, officers, agents, employees, attorneys, servants, volunteers, successors and assigns, immediately upon tender to City of the claim in any form or at any stage of an action or proceeding, whether or not liability is established. An allegation or determination that persons other than Consultant are responsible for the claim does not relieve Consultant from its separate and distinct obligation to defend under this section. The obligation to defend extends through final judgment, including exhaustion of any appeals. The defense obligation includes an obligation to provide independent defense counsel if Consultant asserts that liability is caused in whole or in part by the negligence or willful misconduct of the indemnified party. If it is finally adjudicated that liability was caused by the comparative active negligence or willful misconduct of an indemnified party, Consultant may submit a claim to the City for reimbursement of reasonable attorneys' fees and defense costs in proportion to the established comparative liability of the indemnified party.

4.4 City shall have the right to offset against the amount of any compensation due Consultant under this Agreement any amount due City from Consultant as a result of Consultant's failure to pay City promptly any indemnification arising under this Article and related to Consultant's failure to either (i) pay taxes on amounts received pursuant to this Agreement or (ii) comply with applicable workers' compensation laws.

4.5 The obligations of Consultant under this Article will not be limited by the provisions of any workers' compensation act or similar act. Consultant expressly waives its statutory immunity under such statutes or laws as to City and City's engineer, elected and appointed officials, officers, employees, agents and volunteers.

4.6 Consultant agrees to obtain executed indemnity agreements with provisions identical to those set forth here in this Article from each and every subcontractor or any other person or entity involved by, for,

with or on behalf of Consultant in the performance of this Agreement. In the event Consultant fails to obtain such indemnity obligations from others as required herein, Consultant agrees to be fully responsible and indemnify, hold harmless and defend City and City's engineer, elected and appointed officials, officers, employees, agents and volunteers from and against any and all claims and losses, costs or expenses for any damage due to death or injury to any person and injury to any property resulting from any alleged intentional, reckless, negligent, or otherwise wrongful acts, errors or omissions of Consultant's subcontractors or any other person or entity involved by, for, with or on behalf of Consultant in the performance of this Agreement. Such costs and expenses shall include reasonable attorneys' fees incurred by counsel of City's choice.

4.7 The City does not, and shall not, waive any rights that it may possess against Consultant because of the acceptance by the City, or the deposit with the City, of any insurance policy or certificate required pursuant to this Agreement. This hold harmless and indemnification provision shall apply regardless of whether or not any insurance policies are determined to be applicable to the claim, demand, damage, liability, loss, cost or expense.

4.8 This Article and all provisions contained herein (including but not limited to the duty to indemnify, defend and hold free and harmless) shall survive the termination or normal expiration of this Agreement and is in addition to any other rights or remedies which the City may have at law or in equity.

V. TERMINATION

5.1 TERMINATION WITHOUT CAUSE: CITY may terminate this Agreement at any time for convenience and without cause by giving written notice to CONSULTANT at least five (5) calendar days prior to the effective date of such termination for convenience. Upon termination for convenience, CONSULTANT shall be compensated only for the Work which has been adequately rendered to CITY up to the effective date of the termination, and CONSULTANT shall be entitled to no further compensation. CONSULTANT may not terminate this Agreement except for breach of this Agreement. If this Agreement is terminated as provided herein, CITY may require CONSULTANT to provide all finished or unfinished Documents and Data, as defined in Section 7.1 below, and other information of any kind prepared by CONSULTANT in connection with the performance of the Work. CONSULTANT shall be required to provide such documents and other information within fifteen (15) calendar days of the request. In the event this Agreement is terminated in whole or in part as provided herein, CITY may procure, upon such terms and in such manner as it may determine appropriate, Work similar to those terminated.

5.2 DEFAULT, BREACH AND TERMINATION IN THE EVENT OF BREACH: In the event either Party fails to perform, or adhere to, any applicable duty, obligation or standard of conduct set forth under this Agreement (or fails to perform or adhere to any such duty, obligation or standard of conduct at the time, place or manner set forth in this Agreement), an event of default (hereinafter, "Event of Default") shall have occurred. Except as otherwise provided in this Agreement, if an Event of Default remains uncured by the defaulting Party for a period in excess of fourteen (14) calendar days from the date upon which the non-defaulting Party issues notice of default (hereinafter, a "Default Notice") to the defaulting Party, then the default shall constitute a breach of this Agreement. If a Party is in breach of this Agreement, the non-breaching Party may pursue any and all remedies available to it at law or in equity. If CONSULTANT is in breach (whether or not such breach is caused by CONSULTANT or CONSULTANT's officials, officers, employees, agents, contractors, subcontractors or subconsultants, CITY may, in its sole and absolute discretion (and without obligation), terminate this Agreement immediately upon the issuance written notice of termination on the grounds of breach (a "Breach-Termination Notice") which notice shall specify the effective date of such termination for cause. CITY's ability to terminate this Agreement as provided in this Section shall be in addition to any other remedies CITY may have at law or in equity in the event of breach and shall not be in lieu of such other remedies.

- 5.3 **SCOPE OF WAIVER:** No waiver of any default or breach under this Agreement shall constitute a waiver of any other default or breach, whether of the same or other covenant, warranty, agreement, term, condition, duty or requirement contained in this Agreement. No waiver, benefit, privilege, or service voluntarily given or performed by a Party shall give the other Party any contractual rights by custom, estoppel, or otherwise.
- 5.4 **SURVIVING ARTICLES, SECTIONS AND PROVISIONS:** The termination of this Agreement pursuant to any provision of this Article or by normal expiration of its term or any extension thereto shall not operate to terminate any Article, Section or provision contained herein which provides that it shall survive the termination or normal expiration of this Agreement.

VI.
MISCELLANEOUS PROVISIONS

- 6.1 **DOCUMENTS & DATA; LICENSING OF INTELLECTUAL PROPERTY:** All Documents and Data shall be and remain the property of CITY without restriction or limitation upon their use or dissemination by CITY. For purposes of this Agreement, the term "Documents and Data" means and includes all reports, studies, analyses, correspondence, plans, drawings, designs, renderings, specifications, notes, summaries, strategies, charts, schedules, spreadsheets, calculations, lists, data compilations, documents or other materials developed and/or assembled by or on behalf of CONSULTANT in the performance of this Agreement and fixed in any tangible medium of expression, including but not limited to Documents and Data stored on paper, digitally, magnetically and/or electronically. CONSULTANT shall require all subcontractors and subconsultants working on behalf of CONSULTANT in the performance of this Agreement to agree in writing that CITY shall be granted the same right to copy, use, reuse, disseminate and retain Documents and Data prepared or assembled by any subcontractor or subconsultant as applies to Documents and Data prepared by CONSULTANT in the performance of this Agreement.
- 6.2 **CONFIDENTIALITY:** All ideas, memoranda, specifications, plans, procedures, drawings, descriptions, computer program data, input recorded data, written information, and other like information either created by or provided to CONSULTANT in connection with the performance of this Agreement shall be held confidentially by CONSULTANT. Such materials shall not, without the prior written consent of CITY, be used by CONSULTANT for any purposes other than the performance of the Work. Nor shall such materials be disclosed to any person or entity not connected with the performance of the Work. Nothing furnished to CONSULTANT which is otherwise known to CONSULTANT or is generally known, or has become known, to the related industry shall be deemed confidential. CONSULTANT shall not use CITY's name or insignia, photographs, or any publicity pertaining to the Work in any magazine, trade paper, newspaper, television or radio production or other similar medium without the prior written consent of CITY.
- 6.3 **NOTICES:** All notices permitted or required under this Agreement shall be given to the respective Parties at the following addresses, or at such other address as the respective Parties may provide in writing for this purpose:

CONSULTANT:

[Name, Address, Phone, Fax, and other relevant contact information for Consultant]

CITY:

City of San Fernando
Attn: Deputy City Manager
117 Macneil Street
San Fernando, CA 91340
Tel: (818) 898-1222

Such notices shall be deemed effective when (i) personally delivered; (ii) successfully transmitted by facsimile as evidenced by a fax confirmation slip; (iii) when successfully transmitted and received via electronic mail at any of the e-mail addresses listed above; or (iv) when mailed, forty-eight (48) hours

after deposit with the United States Postal Service, first class postage prepared and addressed to the Party at its applicable address.

- 6.4 COOPERATION; FURTHER ACTS: The Parties shall fully cooperate with one another, and shall take any additional acts or sign any additional documents as is reasonably necessary, appropriate or convenient to achieve the purposes of this Agreement.
- 6.5 SUBCONTRACTING: CONSULTANT shall not subcontract any portion of the Work required by this Agreement, except as expressly stated herein, without the prior written approval of CITY. Subcontracts (including without limitation subcontracts with subconsultants), if any, shall contain a provision making them subject to all provisions stipulated in this Agreement, including provisions relating to insurance requirements and indemnification.
- 6.6 CITY'S RIGHT TO EMPLOY OTHER CONSULTANTS: CITY reserves the right to employ other consultants in connection with the various projects worked upon by CONSULTANT.
- 6.7 PROHIBITED INTERESTS: CONSULTANT warrants, represents and maintains that it has not employed nor retained any company or person, other than a *bona fide* employee working solely for CONSULTANT, to solicit or secure this Agreement. Further, CONSULTANT warrants and represents that it has not paid nor has it agreed to pay any company or person, other than a *bona fide* employee working solely for CONSULTANT, any fee, commission, percentage, brokerage fee, gift or other consideration contingent upon or resulting from the award or making of this Agreement. For breach or violation of this warranty, CITY shall have the right to rescind this Agreement without liability. For the term of this Agreement, no member, officer or employee of CITY, during the term of his or her service with CITY, shall have any direct interest in this Agreement, or obtain any present or anticipated material benefit arising therefrom.
- 6.8 TIME IS OF THE ESSENCE: Time is of the essence for each and every provision of this Agreement.
- 6.9 FORCE MAJEURE: Any prevention, delay, nonperformance or stoppage due to any of the following causes shall excuse nonperformance for a period equal to such obligations imposed by this Agreement. The causes referred to above are strikes, walkouts, labor disputes, failure of power, irresistible superhuman cause, acts of public enemies of the State or United States, riots, insurrections, civil commotion, inability to obtain labor or material or reasonable substitutes for either, governmental restrictions or regulations or controls (except those reasonably foreseeable in connection with the uses contemplated by this Agreement), casualties not contemplated by insurance provisions of this agreement, or other causes beyond the reasonable control of the party obligated to perform.
- 6.10 GOVERNING LAW; VENUE: This Agreement shall be interpreted and governed according to the laws of the State of California. In the event of litigation between the Parties, venue, without exception, shall be in the Los Angeles County Superior Court of the State of California. If, and only if, applicable law requires that all or part of any such litigation be tried exclusively in federal court, venue, without exception, shall be in the Central District of California located in the City of Los Angeles, California.
- 6.11 ATTORNEY'S FEES: If either Party commences an action against the other Party, either legal, administrative or otherwise, arising out of or in connection with this Agreement, the prevailing Party in such litigation shall be entitled to have and recover from the losing Party reasonable attorney's fees and all other costs of such action.
- 6.12 SUCCESSORS AND ASSIGNS: This Agreement shall be binding on the successors and assigns of the Parties.

- 6.13 NO THIRD PARTY BENEFIT: There are no intended third party beneficiaries of any right or obligation assumed by the Parties. All rights and benefits under this Agreement inure exclusively to the Parties.
- 6.14 CONSTRUCTION OF AGREEMENT: This Agreement shall not be construed in favor of, or against, either Party but shall be construed as if the Parties prepared this Agreement together through a process of negotiation and with the advice of their respective attorneys.
- 6.15 SEVERABILITY: If any portion of this Agreement is declared invalid, illegal, or otherwise unenforceable by a court of competent jurisdiction, the remaining provisions shall continue in full force and effect.
- 6.16 AMENDMENT; MODIFICATION: No amendment, modification or supplement of this Agreement shall be valid or binding unless executed in writing and signed by both Parties, subject to CITY approval. The requirement for written amendments, modifications or supplements cannot be waived and any attempted waiver shall be void and invalid.
- 6.17 CAPTIONS: The captions of the various articles, sections and paragraphs are for convenience and ease of reference only, and do not define, limits, augment, or describe the scope, content, or intent of this Agreement.
- 6.18 INCONSISTENCIES OR CONFLICTS: In the event of any conflict or inconsistency between the provisions of this Agreement and any of the exhibits attached hereto, the provisions of this Agreement shall control.
- 6.19 ENTIRE AGREEMENT: This Agreement including all attached exhibits is the entire, complete, final and exclusive expression of the Parties with respect to the matters addressed herein and supersedes all other agreements or understandings, whether oral or written, or entered into between CITY and CONSULTANT prior to the execution of this Agreement. No statements, representations or other agreements, whether oral or written, made by any Party which are not embodied herein shall be valid or binding. No amendment, modification or supplement to this Agreement shall be valid and binding unless in writing and duly executed by the Parties pursuant to Section 6.16, above.
- 6.20 COUNTERPARTS: This Agreement shall be executed in two (2) original counterparts each of which shall be of equal force and effect. One counterpart shall be delivered to CONSULTANT and the other shall be retained by CITY. No handwritten or typewritten amendment, modification or supplement to any one counterparts shall be valid or binding unless made to all three counterparts in conformity with Section 6.16, above.

[SIGNATURE PAGE TO FOLLOW]

AS OF THE DATE FIRST WRITTEN ABOVE, the Parties evidence their agreement to the terms of this Agreement by signing below:

CITY:
City of San Fernando

By: _____

Name: _____

Title: _____

APPROVED AS TO FORM:

By: _____
City Attorney

CONSULTANT:
California Center for Public Health Advocacy

By: _____

Print: _____

Title: _____

DRAFT

**EXHIBIT "A"
[SCOPE OF WORK]**

DRAFT

EXHIBIT "A"**SCOPE OF WORK CHECKLIST**

The scope of work is the official description of the work that is to be completed during the contract. **The scope of work must be consistent with the project timeline.**

The scope of work must:

- Be completed using the FY 2015-16 template provided and in Microsoft Word format.
- List all tasks and sub-tasks using the same title as stated in the project timeline.
- Have task and sub-task numbers in accurate and proper sequencing; consistent with the project timeline.
- List the responsible party for each task and subtask and ensure that it is consistent with the project timeline (i.e. applicant, sub-applicant, or consultant).
- Have a thorough Introduction to describe the project and project area demographics.
- Have a thorough and accurate narrative description of each task and sub-task.
- Include a task for a kick-off meeting with Caltrans at the start of the grant.
- Include a task for procurement of consultants, if consultants are needed.
- Include a task for invoicing.
- Include a task for quarterly reporting to Caltrans.
- Include public participation and services to diverse communities.
- Include project implementation/next steps.
- NOT include environmental, complex design, or engineering work and other ineligible activities.
- List the project deliverable for each task in a table following each task and ensure that it is consistent with the project timeline.

SCOPE OF WORK

City of San Fernando Safe Routes to School Plan

INTRODUCTION:

The City of San Fernando will develop a comprehensive Safe Routes to School (SRTS) plan aimed at increasing the number of children that walk and ride their bicycle to school. The City will work with the school district, individual schools, parents and youth to identify barriers to walking and bicycling to school sites. The collective findings will be compiled into a plan with detailed design recommendations for physical changes to streets, sidewalks and intersections to support safe and active transportation to all the schools.

In 2012, the City of San Fernando had a population of 23,752 of which 93.1 percent is Hispanic. The median household income is lower than the County of Los Angeles at \$48,300 versus \$53,880. The average household size is much larger than the County at 4.0 persons per household versus 3.0 for the County. Twenty-one (21%) percent of San Fernando households have six or more household members. A total of 52.1 percent of the San Fernando population over 25 years old has completed high school or a higher level of education.

RESPONSIBLE PARTIES:

City of San Fernando is the lead applicant for this project. The City will be the grant recipient, execute the contract with Caltrans and the sub-recipients. The City of San Fernando will review grant products, and perform grant administration functions as required. The City will identify staff members to participate in all aspects of the project and provide staff support to meet the local in-kind match requirement. City staff will select a design and planning consultant, through its existing on-call consultant bench, to develop conceptual and planning drawings to be added to the design and charrette presentation for effective visualization. The selected consultant will provide GIS, conceptual renderings, planning drawings, technical consulting, general infrastructure guidance and expertise.

The California Center for Public Health Advocacy (CCPHA) is the sub-recipient for this project. CCPHA is a nonprofit 501(c)3 organization that has been working in the San Gabriel Valley region since 1999 in creating policies for healthier community living. CCPHA has been the lead organization for multiple regional initiatives, including, Healthy Kids Healthy Communities (HKHC), First 5, LA RENEW, and the Healthy Eating Active Communities (HEAC) project. CCPHA will lead all community participation and engagement strategies of the grant including ensuring a well-established resident led safe routes advisory group to expand communication with the City on all transportation issues affecting safety and quality of life.

OVERALL PROJECT OBJECTIVES:

The primary objective will be to develop recommendations for infrastructure changes to improve safe walking and bicycling to all 11 schools in and around the 2.4 square miles of the City of San Fernando. The plan will also include recommendations for non-infrastructure programs such as “walking school buses” or “rewards programs” that make use of the other SRTS “E”s, namely Encouragement, Education and Enforcement. These programs can be implemented in the short term to motivate parents and children to walk and ride a bicycle to school and have been proven to

be very successful in other cities in the nation. This project will benefit the underprivileged and under-represented minority population who have had a perceived lack of confidence in the safety of their streets and neighborhoods.

TASK 1. PROJECT MANAGEMENT AND COORDINATION

Task 1.1: Project Kickoff Meeting

San Fernando City staff will conduct a kick-off meeting with Caltrans staff to discuss scope of work, grant procedures and project expectations including invoicing, quarterly progress reports, and other relevant project information.

- Responsible Party: City of San Fernando

Task 1.2: Contracting with Sub-Applicants

City staff will prepare a subcontract with the California Center for Public Health Advocacy (CCPHA), the sub-applicant on this grant who will work in partnership with the selected consultant and the City to coordinate all aspects of the community engagement for the project.

- Responsible Party: City of San Fernando

Task 1.3: Project Team Kick-Off Meeting

Kick-off meeting with city staff, selected consultant and CCPHA to discuss scope of work, timeline/budget, review tasks and objectives, and expectations of deliverables. Project team will prepare an action plan that will coordinate outreach efforts and establish a coordinated timeline. City staff will provide consultant with available information on existing conditions for the project areas, including area photos, traffic volumes, crash data, regional transportation plans, state route planning and construction plans, aerial and base maps, General Plan and other policy documents, development standards and regulations, and other relevant studies.

- Responsible Party: City, Consultant, CCPHA

Task 1.4: Staff Coordination – Team Meetings

Conduct monthly team coordination meetings with consultant, city staff and CCPHA to maintain good communication throughout the project, provide updates on deliverables, and ensure project is on time and within budget. City staff will collect all pertinent deliverables for the quarter to submit with quarterly report to Caltrans. Other discussions will be plan development, recommendations and next steps.

- Responsible Party: City, Consultant, CCPHA

Task	Deliverables
1.1	Copy of agenda, meeting summary and final scope of work
1.2	Copy of executed subcontract with CCPHA
1.3	Copy of agenda, meeting summary, outreach action plan, sign-in sheet & list of collected data
1.4	Copy of agendas, meeting summaries and sign-in sheet

TASK 2: PUBLIC OUTRTEACH AND PARTICIPATION

Description: A series of planning presentations and activities are scheduled for this community-based planning effort and is expected to span over a three-month period. The purpose of the presentation and activities will be to work with community residents, school officials and City public safety staff to establish guiding principles, identify problems, and discuss proposed strategies to increase walking and bicycling to schools and local businesses. Strategies will include street and intersection design concepts that improve safety for walking and bicycling, changes to the drop-off and pick-up procedures at the school to reduce congestion and potential for collisions around the school, and the full range of non-infrastructure programs (including education, encouragement, enforcement and evaluation) that can support more walking and bicycling. The City will work with the selected consultant to coordinate all presentation materials and develop planning activities (such as charrettes, concept renderings and lessons learned programs from other successful agencies and bring in CCPHA to intergrade the attendees comments and concerns into the planning design for all transportation modes. To prepare community members to participate in these planning activities, CCPHA will organize a series of educational workshops prior to and during these events.

Task 2.1: Assemble Community Advisory Committee

CCPHA, in coordination with consultant, city staff, and the Transportation and Safety Commission, will assemble a Community Advisory Committee to provide input as the project moves forward. The Advisory Committee will include City staff, local school staff, representatives from service organizations, faith-based community, businesses, neighborhood leaders, youth, and other interest groups that reflect the demographics and perspectives of the community. The Community Advisory Committee of 8 to 12 representatives from agencies and the community will be consulted throughout the project and serve as a sounding board. The Community Advisory Committee will assist in scheduling, coordinating and participating in the mini-charrettes that will be held throughout the community during the duration of the project. The Committee will work to identify additional community leaders, determine strategies to engage all segments of the community, maximize community participation, assist with school site observations, develop infrastructure recommendations to improve safe walking and bicycling to schools, and advocate for the project.

- Responsible Party: CCPHA and Consultant

Task 2.2: Community Advisory Committee Kick-off Meeting

CCPHA will facilitate a kick-off meeting with the Community Advisory Committee to discuss the project, scope of work, community outreach action plan, and project timeline. The Committee's role will be identified along with their expectations. A brief presentation of existing conditions and an overview of Complete Streets will be provided. The Committee will discuss the schedule for the upcoming mini-charrettes and members will be assigned selected schools for their observation assignment. They will develop a list of key stakeholders to invite, identifying problem areas to study, and identify strategies for engaging residents, in particular underrepresented residents.

- Responsible Party: CCPHA

Task 2.3: Pre-Charrette Visit

Consultant will conduct a one-day pre-charrette visit to coincide with the first Community Advisory Committee meeting (see Task 2.1) to meet with the project partners and selected stakeholders, and tour and photograph the areas to assess existing conditions.

- Responsible Party: Consultant

Task 2.4: Pre-Charrette Community Workshops

CCPHA, in coordination with city staff, will organize two (2) educational and awareness workshops for the residents, businesses, school officials and public safety staff, who were identified by the Advisory Committee, to provide them with the information and skills they need to help facilitate the mini-charrettes. The workshops will entail leadership training exercises to develop the skills they need to perform the walkability and bikability audits, use of assessment tools and how to develop a Safe Routes to School Plans. The 90-minute workshops will be offered in English and Spanish, including written materials and participant activities.

- Responsible Party: CCPHA and city staff

Task 2.5: Community Charrettes and Assessment Tours

City consultant and CCPHA will conduct three (3) two-day neighborhood charrettes and tours. Each charrette will be conducted either at school or city facilities and will address issues at all elementary, middle and high schools. Each charrette and tour will consist of the following events:

- Short tour and observation of the morning arrival of students at the school.
- Morning workshop with parents, school and public safety staff and police to discuss the key elements of Safe Streets and Safe Routes to School programs.
- Walkability and Bike-ability Audits around the school to identify the challenges children face in walking or bicycling to school.
- Design table exercise after Walkability and Bike-ability Audits where parents, business owners, city and school staff and neighbors will be able to draw or write their comments, concerns and ideas on aerial photographs of the area around the school.
- Activity with a 5th (elementary school aged) and 6th (middle school aged) grade class that asks children to draw their route to school and what they think of the safety of walking and biking to school. Also, to discuss the perceived dangers along Huntington Drive and their suggested improvements.
- Present at School Board, Traffic Commission and Parents Teachers Association meetings to present the recommendations.

- **Responsible Party:** City staff, Consultant and CCPHA

Task 2.6: Produce and Distribute Outreach Material

CCPHA will produce Announcements/Flyers/Mailers/Posters publicizing the meetings for community-wide distribution. Flyers will be produced in English and Spanish. The City, local businesses, community based organizations, school based liaisons, faith-based and service organizations, will be asked to distribute flyers and information about the meetings through their communication networks. Elementary, Middle and High Schools will be asked to send flyers home with their students. CCPHA will distribute flyers to neighborhood residents through community churches and other identified channels. A communications plan and media outreach materials will be developed, which may include press releases/alerts and project fact sheet(s) for distribution and outreach to local media. The project partners will work on setting up community wide signs or banners announcing events. Information will be posted on the City and School District website, community marquee and local paper.

- Responsible Party: CCPHA

Task	Deliverable
2.1	Outreach list, e-mail correspondence and Advisory Committee roster
2.2	Meeting Agenda, e-mail correspondence, PowerPoint presentation, sign-in sheet, meeting summary with outcomes and next steps.
2.3	Assessment of projects area, site photos and preliminary summary of tour
2.4	Meeting Agenda, e-mail correspondence, PowerPoint presentation, fact sheet,

	promotional materials, sign-in sheet, meeting summary with outcomes and next steps.
2.5	Maps, assessment/observation tools, agenda, e-mail correspondence, PowerPoint presentation, fact sheet, promotional materials, sign-in sheet, summary of process and results, photos of audits and parent workshop.
2.6	Announcements/Flyers/Mailers/Posters/distribution list

TASK 3: PREPARATION OF SAFE ROUTES TO SCHOOL PLAN

Task 3.1: Prepare Base Maps

Consultant will prepare all base maps for assessment, analysis and design work to be used for all community meetings and design charrettes.

- Responsible Party: Consultant

Task 3.2: Review of Data Collection and Existing Conditions

Consultant will review and analyze all data collected from the City. Data may include: existing conditions for project areas, area photos, traffic volumes, crash data, regional transportation plans, planning and construction plans, CIP projects, aerials and base maps, general plan and other policy documents, development standards and regulations and other relevant studies.

- Responsible Party: Consultant

Task 3.3: Plan Outline

After the mini-charrettes the consultant team will prepare an outline of the Safe Routes to School Plan and a list of any additional questions, concerns or critical/controversial issues that might have emerged during or after the charrettes. This outline will be circulated to select stakeholders, including school district and city staff and the Advisory Committee for comment.

- Responsible Party: Consultant

Task 3.4: Preparation of Administrative Draft Plan

Within two to three months after the planning and charrette workshops, the project team will prepare an administrative draft. The plan will include recommendations to improve safety conditions for walking and bicycling to all elementary, middle and high schools. The plan will also include conceptual designs, recommendations and development standards for improved road safety and operations, pedestrian, bicycle and transit facilities, and enhanced safety features and streetscapes. The plan will also contain a record of the planning and charrette process, proposed timing and prioritization for implementation of the recommendations, and potential funding sources.

- Responsible Party: Consultant

Task 3.5: Draft Plan Comments

City staff and consultants will circulate the draft plan to City and School District staff, City public safety and Police, Caltrans staff and the Advisory Committee for feedback. Consultant will collect and review all comments and provide a comprehensive set of consistent comments to the City and project team.

- Responsible Party: Consultant

Task	Deliverable
3.1	Copies of base maps
3.2	Copies of all data collected and summary of analysis
3.3	Copy of Outline
3.4	Administrative Draft – Safe Routes to School Plan
3.5	Matrix of all comments collected

Task 4: ADOPTION OF SAFE ROUTES TO SCHOOL PLAN

Task 4.1: Advisory Committee/Community Meeting

The consultant will facilitate a final Community Meeting where they will present the draft Plan and provide an overview of the completed project. Final recommendations will be received and incorporated into the final document to be presented to the Planning Commission and City Council. Additionally, staff will work with selected community members to attend the public hearings to provide testimony of their involvement and speak in favor of the project.

- Responsible Party: Consultant, CCPHA, City Staff

Task 4.2: Planning Commission Meeting

Consultant and city staff will present the final study for Planning Commission consideration and recommendation of approval to the City Council. This meeting will be noticed as a public hearing and the public will have an opportunity to comment and speak in support of the project.

- Responsible Party: Consultant and City Staff

Task 4.3: City Council Meeting

The Safe Routes to School Plan will be considered by the City Council for approval and adoption. This meeting will be noticed as a public hearing and the public will have an opportunity to comment and speak in support of the project.

- Responsible Party: Consultant and City Staff

Task	Deliverable
4.1	Agenda, copy of presentation, summary of outcomes and next steps, sign-in sheet, e-mail correspondence and copies of promotional material(s).
4.2	Planning Commission Agenda, copies of promotional material(s), presentation, and copy of commission minutes
4.3	City Council Agenda, copies of promotional material(s), presentation, and copy of City council minutes

TASK 5: PROJECT MANAGEMENT AND ADMINISTRATION

Task 5.1: Project Administration

Project administration will occur between the consultant and the City of San Fernando. This will consist of weekly teleconferences and monthly progress reports and invoices. This process will ensure proper documentation of expenditures and timely use of funds. Monthly invoices will be submitted to the Caltrans project manager for processing and reimbursement.

- Responsible Party: Consultant and City Staff

Task 5.2: Quarterly Reports

Monitor ongoing progress and prepare quarterly reports, identifying milestones. SCAG in coordination with San Fernando staff will submit quarterly reports to Caltrans district staff providing a summary of project progress and grant/local match/in-kind expenditures.

- Responsible Party: Consultant and City Staff

Task	Deliverable
5.1	Monthly progress reports and invoices
5.2	Quarterly progress reports and invoices

**ATTACHMENT "D"
CONTRACT NO. 1808****MEMORANDUM OF UNDERSTANDING****Between the City of San Fernando and
the County of Los Angeles Department of Public Health**

By this Memorandum of Understanding (MOU), entered into this 7th day of December 2015, the City of San Fernando and the County of Los Angeles Department of Public Health (DPH) agree to partner together in the creation of the City of San Fernando Active Transportation Plan. The City of San Fernando (City) and the County of Los Angeles Department of Public Health (DPH) may be referred to in this MOU as "Party" or "Parties", depending on the context.

The decision to partner together to complete an Active Transportation Plan for the City of San Fernando is a mutual agreement between the City and DPH. The Parties agree as follows:

1. This MOU shall remain in effect for up to eighteen months, effective December 8, 2015 and continuing through June 8, 2017, unless terminated sooner by either Party. Either Party may terminate this MOU by providing 30 days' written notice of termination to the other Party.
2. The Parties shall on an as-needed basis meet to evaluate the services being provided and discuss items of mutual concern.
3. No later than March 8, 2017, the Parties shall meet to determine if this MOU will continue after June 8, 2017. The Parties may mutually agree in writing to extend the term of this MOU or enter into a separate MOU covering the same subjects.
4. The Parties shall each handle all aspects of registration for all participants in their respective communities.

5. The *City of San Fernando* agrees to contribute to this agreement by:
 1. **Access to City Office Space.** The City will allow DPH access to City office space, including conference rooms, computer/phone access in conjunction with this partnership.
 2. **Access to City Personnel/Consultants:** The City shall make reasonable access to personnel and/or consultants associated with the preparation of sustainable transportation plan documents for the community (including the Safe Routes to School Plan and Active Transportation Plan).
 3. **Indemnification:** The City agrees to indemnify and hold harmless DPH, its employees, agents and volunteers from any liability, obligation, cost, claim or damage howsoever caused, by reason of any injury, whether to body, property or to any person or to property by reason of any act, neglect, default or omission of the City or any of its agents, employees, subcontracts or other representatives, arising out of or in any way connected with the City's performance of services.
 4. **Payment:** No payment shall be made by the City in conjunction with this partnership.

6. The *County of Los Angeles Department of Public Health* agrees to contribute to this agreement by:
 1. **Staff Assistance.** DPH shall agree to provide staffing support to the City in conjunction with the completion of a City Active Transportation Plan.
 2. **Traffic Monitoring Equipment:** DPH shall allow the City to utilize related equipment (i.e. traffic or pedestrian counters) in conjunction with the completion of studies related to this planning effort.
 3. **Indemnification:** DPH agrees to indemnify and hold harmless the City, its employees, agents and volunteers from any liability, obligation, cost, claim or damage howsoever caused, by reason of any injury, whether to body, property or to any person or to property by reason of any act, neglect, default or omission of DPH or any of its agents, employees, subcontracts or other representatives, arising out of or in any way connected with the DPH's performance of services.
 4. **Payment:** DPH shall not request payment or reimbursement of costs related to this partnership.

7. The Parties shall negotiate all items not specifically covered under this Memorandum of Understanding.

In acknowledgement of the terms and conditions set forth herein, the Parties have caused this Memorandum of Understanding to be executed by their authorized officers:

City of San Fernando

By: _____

Date: _____

County of Los Angeles Department of Public Health

By: _____

Date: _____

*This Page
Intentionally
Left Blank*

*This Page
Intentionally
Left Blank*



AGENDA REPORT

To: Mayor Joel Fajardo and Councilmembers

From: Brian Saeki, City Manager
By: Fred Ramirez, Community Development Director

Date: December 7, 2015

Subject: Consideration to Adopt Urgency Ordinance No. U-1649 of the City of San Fernando Making Findings and Establishing an Interim Moratorium on the Application Filing, Processing, Approval and Issuance of Permits for Multiple-Family Dwelling Projects

RECOMMENDATION:

It is recommended that the City Council:

- a. Conduct a Public Hearing; and
- b. Pending public testimony, waive full reading and adopt Urgency Ordinance No. U-1649 (Attachment "A") by title, "An Urgency Ordinance of the City Council of the City of San Fernando Instituting An Interim Moratorium on the Application Filing, Processing, Approval and Issuance of Permits for Multiple-Family Dwelling Projects." This Ordinance is introduced pursuant to Government Code Section 36937(b) and requires a four-fifths (4/5ths) vote for adoption.

BACKGROUND:

On November 6, 2015, the City Council considered a request brought forth by Vice Mayor Sylvia Ballin for a "Moratorium on Any Multi-Unit Housing of Four Units or More". As part of the City Council discussion, concerns were raised about the potential impact of multiple family dwellings projects to the City's aging infrastructure inclusive of streets, water, sewer, lighting, et cetera. Subsequent to discussion, the City Council voted to direct City Staff and the City Attorney to bring back an urgency ordinance regarding multiple-family dwelling projects for consideration at the December 7, 2015 City Council Meeting.

Consideration to Adopt Urgency Ordinance No. U-1649 of the City of San Fernando Making Findings and Establishing an Interim Moratorium on the Application Filing, Processing, Approval and Issuance of Permits for Multiple-Family Dwelling Projects

Page 2 of 5

ANALYSIS:

City Authority.

The California Constitution Article XI, Section 7, enables the City of San Fernando (the "City") to enact local planning and land use regulations. The authority to adopt and enforce zoning regulations is an exercise of the City's police power to protect the public health, safety, and welfare.

California Government Code section 65858 authorizes the City Council to adopt an urgency ordinance for the immediate preservation of the public health, safety, or welfare, and to prohibit a land use that is in conflict with a contemplated general plan, specific plan, or zoning proposal that the City Council, Planning Commission, or Community Development Department is considering or studying or intends to study within a reasonable time.

City Definitions of Multiple Family Dwelling and Dwelling.

Multiple-Family Dwellings and Dwelling are defined in the City's Zoning Ordinance (Chapter 106 (Zoning), Article I, City Code Section 106-6 (Definitions)) as noted below:

"Dwelling, multiple-family means a dwelling consisting of three or more dwelling units per lot, including townhouses, condominiums, apartments."

"Dwelling means a building containing one or more dwelling units. A group quarters or other building or portion thereof devoted primarily to rooming units shall not be considered to be a dwelling."

The definition of Dwelling and Multiple-Family Dwelling have remained unchanged since the City's last comprehensive zoning ordinance update that occurred in June of 1987 (City Council Ordinance No. 1305).

Multiple-Family Dwelling Projects (2010-2015).

The following Multiple-Family Dwelling Projects have been entitled and/or built in the past five (5) years:

- 131 Park Ave. = 61 Units (Planning Commission Approved in 2010; Built in 2013)
- 1422 San Fernando Rd. = 20 Units (Council Approved in 2011; Built in 2013)
- 124 Harding Ave. = 29 Units (Council Approved in 2012; Built in 2015)

Consideration to Adopt Urgency Ordinance No. U-1649 of the City of San Fernando Making Findings and Establishing an Interim Moratorium on the Application Filing, Processing, Approval and Issuance of Permits for Multiple-Family Dwelling Projects

Page 3 of 5

- 1501-1529 First St./Fermoore St. = 100 Units (Council Approved in 2012; Not Yet Built)
- 1011 Seventh St. = 16 Units (By-Right Project-City Approved in 2013; Built in 2014)
- 1140-1148 San Fernando Rd. = 101 Units (Council Approved in 2014; Not Yet Built)
- 1407 Celis St. = 6 Units (By-Right Project-City Approved in 2015; Not Yet Built)
- 1001 Glenoaks Blvd. = 6 Units (City Review 2015; Requires Commission/Council Approval)

Reasons for Considering A Moratorium Now.

Multiple factors affect council consideration of the proposed moratorium including:

- Decades of deferred maintenance on the City's infrastructure including streets, water, sewer and lighting, which have accompanied utility rate increases in water and sewer infrastructure and associated short and long-term Capital Improvement Program (CIP) projects to upgrade said utilities;
- Pending participation in the Total Road Improvement Program, which will help expedite needed improvements to the local road and traffic infrastructure, which is expected to be approved in spring 2016;
- Pending completion of City Council-approved, 100% Closed Circuit Television (CCTV) assessment of City sewer system and implementation of identified point repairs and/or design of replacement of sewer line segments, which are to be initiated in spring 2016;
- Fee Study for City Services (projected completion by June of 2016) including possible creation of Development Impact Fees ("DIFs") to address project impacts on City infrastructure;
- Renewed interest in the development of multiple-family dwelling projects within the City's multiple family dwelling zones including R-3 (Multiple Family) zoned properties on Park Avenue, Jessie Street, First Street, and Harding Avenue and within the City's SP-4 (Corridors Specific Plan) zone which includes the commercial corridors on Maclay Avenue, San Fernando Road, and Truman Street;
- "Multiple-Family Dwelling Projects" approved over the past five years; and,

Consideration to Adopt Urgency Ordinance No. U-1649 of the City of San Fernando Making Findings and Establishing an Interim Moratorium on the Application Filing, Processing, Approval and Issuance of Permits for Multiple-Family Dwelling Projects

Page 4 of 5

- Proposed update of the San Fernando Corridors Specific Plan and associated Environmental Impact Report (projected completion by July of 2016) as part of the proposed TOD Overlay Zone Project that will be considering the total number and potential zoning districts where multiple-family dwelling projects could be developed within the amended specific plan area and any potential environmental impacts that includes review of the potential impacts to City infrastructure.

The City expects additional request to develop Multiple-Family Dwelling Projects (defined by City Zoning Ordinance as “dwelling consisting of three or more dwelling units per lot, including townhouses, condominiums, apartments”) will continue as demand for housing continues to increase local, regionally, and at the state level. City Planning staff is seeking a moratorium on the acceptance, processing, and approval of new Multiple-Family Dwelling Projects in order to provide a reasonable period of time to: study current conditions of City infrastructure; review City CIP projects related to streets, water, and sewer; consider current development fees and possible need for DIFs; and, assess potential impacts of new Multiple-Family Dwelling Projects built by right under the current zoning regulations or as part the proposed San Fernando Corridors Specific Plan Update/TOD Overlay Zone Project.

Based on the reasons noted above, the City Staff and the City Attorney recommend that the City Council adopt the attached Urgency Ordinance No. U-1649 at this time in order to establish a temporary moratorium on the acceptance, processing, and approval of applications and issuance of permits to construct Multiple-Family Dwelling Projects. The proposed Urgency Ordinance includes the following exceptions to the temporary moratorium for previously city-approved Multiple-Family Dwelling Projects:

- Multiple-Family Dwelling Projects that have been deemed approved by the City prior to the effective date of this temporary moratorium as it pertains to any required Site Plan Review Application for any by-right project under the City’s Zoning Ordinance.
- Multiple-Family Dwelling Projects that have been deemed approved by the City prior to the effective date of this temporary moratorium that required a zone change, discretionary permit that was reviewed by the Planning and Preservation Commission and subsequently reviewed and approved by the City Council.

CEQA Compliance.

The proposed Urgency Ordinance has been reviewed for compliance with the California Environmental Quality Act (CEQA). Based on that assessment, the proposed Urgency Ordinance has been determined to be exempt from CEQA review pursuant to Title 14, Sections 15061(b)(3), 15306, 15308, and 15378 of the California Code of Regulations.

Consideration to Adopt Urgency Ordinance No. U-1649 of the City of San Fernando Making Findings and Establishing an Interim Moratorium on the Application Filing, Processing, Approval and Issuance of Permits for Multiple-Family Dwelling Projects

Page 5 of 5

BUDGET IMPACT:

Approval of this Urgency Ordinance is not expected to have any direct impact on the City's budget during the initial 45-day period, as the City staff time and the legal fees from the City Attorney's office for work on a permanent ordinance amendment would be covered under the current budget. Potential future extensions may result in a reduction in City General Fund revenue attributed to permit and development fees associated with new construction of Multiple-Family Dwelling Projects.

CONCLUSION:

Based on the aforementioned analysis, it is recommended that the City Council adopt the Urgency Ordinance No. U-1649 (Attachment "A"). The Urgency Ordinance allows City Staff and the City Attorney to study: the City infrastructure's current capacity and long-term service delivery needs; implementation of a multi-year CIP to address current on long-term infrastructure capacity needs; complete fee study update and review of possible DIFs to offset possible infrastructure impacts from Multiple-Family Dwelling Projects; and identify possible opportunities to use Specific Plan Update as part of TOD Overlay Zone Project and associated EIR as a way of further identifying infrastructure impacts and needed mitigation measures resulting from new projects within the specific plan, planning area. In addition to the aforementioned analysis, City staff will undertake the following after City Council approval of the Urgency Ordinance:

- Issue a written status report to the City Council within 35 days describing the measures taken to alleviate the conditions which led to the adoption of the proposed Urgency Ordinance; and
- Notice a Public Hearing to occur within 45 days that will consider the extension of the proposed Urgency Ordinance if necessary.

ATTACHMENT:

A. Urgency Ordinance No. U-1649

ATTACHMENT “A”**URGENCY ORDINANCE NO. U-1649****AN URGENCY ORDINANCE OF THE CITY COUNCIL OF THE CITY OF SAN FERNANDO, CALIFORNIA, INSTITUTING AN INTERIM MORATORIUM ON THE APPLICATION FILING, PROCESSING, APPROVAL AND ISSUANCE OF PERMITS FOR MULTIPLE-FAMILY DWELLING PROJECTS**

WHEREAS, California Constitution Article XI, Section 7, enables the City of San Fernando (the “City”) to enact local planning and land use regulations; and

WHEREAS, the authority to adopt and enforce zoning regulations is an exercise of the City’s police power to protect the public health, safety, and welfare; and

WHEREAS, the City desires to ensure that residential development occurs in an orderly manner, in accordance with the goals and objectives of the General Plan; and

WHEREAS, pursuant to California Government Code section 65580 et seq. (Housing Elements), the Regional Housing Need Assessment (RHNA) Allocation Plan—prepared by the Southern California Association of Governments and approved by the state Department of Housing and Community Development—has identified for the City of San Fernando a housing growth need of 217 units projected from 2014 to 2021; and

WHEREAS, based on existing and anticipated development, the City continues to make quantifiable progress toward achieving its assigned share of housing units; and

WHEREAS, the City’s General Plan 2013-2021 Housing Element and 2005 San Fernando Corridors Specific Plan (the “Specific Plan”) envision, among other things, residential development potential along major commercial corridors, in Zone R-3 (Multiple Family), and near the Metrolink Station, and the City is now in the process of updating the Specific Plan and preparing an environment impact report (EIR); and

WHEREAS, a Sanitary Sewer Management Plan Report prepared for the City in 2013 identified the need for a System Evaluation and Capacity Assurance Plan to assess the hydraulic capacity of major sewers, and to develop and implement a sewer master plan; and in March of 2014, the City completed the *Final Report for the Sewer Master Plan*, which included goals to identify system deficiencies, needed upgrades based on current and future growth needs as well as mapping of said infrastructure, and a timeframe for developing a short and long-term Capital Improvement Program (CIP) to make said needed repairs, upgrades, and accommodate projected growth; and

WHEREAS, the City Public Works Department 2011 *Proposal to Increase Water and Sewer Rates* identified nitrate removal from two active water wells that draw from the Sylmar Groundwater Basin and provide the community with potable water as a reason for rate increase; and

WHEREAS, the 2010 City of San Fernando Urban Water Management Plan notes that the City’s groundwater rights are fixed at 3,405 Acre Feet per Year (AFY); and

WHEREAS, the 2005 Specific Plan and the proposed 2015 Specific Plan facilitate multiple family dwelling projects that may increase water demand, which may require additional groundwater production and water purchase; and

WHEREAS, drought conditions in California and the statewide 25 percent water use reduction mandate for cities requires the City of San Fernando to reduce its water consumption; and

WHEREAS, the reliability of the City’s water supply is based on capacity and condition of its infrastructure, as well as demand, which is affected by land use regulations; and

WHEREAS, every two years, the City prepares a Pavement Management System (“PMS”) that evaluates roads and classifies their condition. The 2014 PMS rated approximately 32 percent of the City’s streets at below 55 (out of 100), which is “Fair” with “moderate distress; severe weathering,” and altogether identified approximately \$17.8 million in deferred street maintenance; and

WHEREAS, during Fiscal Year 2015-16, approximately \$2.9 million has been budgeted for road-related improvements that include design and construction for 12 streets, plus traffic, pedestrian safety, streetscape, and bicycle improvements, and aided by the City’s participation in the Total Road Improvement Program utilizing Measure R Local Return Transportation funds; and

WHEREAS, the City’s short and long-term Capital Improvements Program (CIP) foresees multi-year, multi-million dollar projects to improve roads, sidewalks and landscaping, in conjunction with water well and water main upgrades, storm drain, and sewer infrastructure—in accordance with state Water Board-required Sewer System Management Plan (SSMP) and Storm Water Pollution Prevention Plan (SWPPP)—as well as traffic safety, parks and facilities; and

WHEREAS, the City Council desires to study the demands of development on the City’s infrastructure; and to study the potential need for additional public facilities to accommodate future development; and to consider impact fees commensurate with the demands of new development to protect the public health, safety and welfare; and

WHEREAS, the City Council recognizes that City Staff must analyze the data from these assessments, improvement plans, and complete the Specific Plan environmental review process (i.e., preparation of a Program Environmental Impact Report), and respond with appropriate potential regulations and mitigation measures; and

WHEREAS, the City seeks to suspend the approval of multiple-family residential development to provide time to study and develop regulations, mitigation measures, and engineering and planning practices that will balance development with infrastructure capacity; and

WHEREAS, the City desires to acknowledge those development projects that have substantially received the approvals they require to permit construction; and

WHEREAS, the City Council desires to direct Community Development Department Staff and Public Works Department Staff to conduct the necessary studies and to report their findings to both the Planning and Preservation Commission and the City Council within a reasonable time; and

WHEREAS, Government Code section 65858 authorizes the City Council to adopt an urgency ordinance for the immediate preservation of the public health, safety, or welfare, and to prohibit a land use that is in conflict with a contemplated general plan update, specific plan update, or zoning proposal that the City Council, Planning and Preservation Commission, or the Community Development Department is considering or studying or intends to study within a reasonable time.

NOW, THEREFORE, THE CITY COUNCIL OF THE CITY OF SAN FERNANDO, CALIFORNIA, DOES HEREBY ORDAIN AS FOLLOWS:

SECTION 1. Recitals. The above recitals are true and correct and incorporated herein by reference.

SECTION 2. Definition. The term “Dwelling, multiple-family” shall be as defined in Zoning Ordinance section 106-6.

SECTION 3. Moratorium.

A. The City Council declares a moratorium on the application filing, processing, approval and issuance of permits for any multiple-family dwelling project.

B. The moratorium shall be effective for the period set forth in this Urgency Ordinance unless extended or repealed by the City Council.

SECTION 4. Moratorium Exemption. The moratorium shall not apply to any project that has secured at least one of the following approvals prior to the effective date of this ordinance:

- (i) Site Plan Review Application.
- (ii) Zone change.

SECTION 5. Hardship Exemption.

A. The City Council has the authority but no obligation to grant exemptions from the provisions of this Urgency Ordinance where it finds that strict adherence to the moratorium would result in extreme hardship to either the developer or property owner. The City Council may consider any factor relevant to this determination. A finding that the moratorium deprives the owner of all economically viable use of the property shall constitute extreme hardship.

B. Written requests for hardship exemptions shall be filed with the Community Development Department and shall state the grounds for the exemption and provide supporting documentation. The City Council is not required to consider the request any sooner than two weeks after it was filed. The City Council shall approve, approve with conditions, or deny the request by resolution.

SECTION 6. Urgency Findings. This Urgency Ordinance is adopted as an urgency measure pursuant to Government Code Section 65858 and is justified based upon the recitals herein, all evidence in the record, and on the following findings:

A. There is a current and immediate threat to the public health, safety, or welfare, and the approval of additional subdivisions, use permits, variances, building permits, or any other applicable entitlement for use which is required in order to comply with a zoning ordinance would result in that threat to public health, safety, or welfare:

A report to the City Council by the Public Works Director, dated August 3, 2015, details the need to inspect 74 percent of the City's sanitary sewer system (approximately 164,000 feet in length) with remote-controlled cameras, to locate damaged pipes and generally to assess the system's condition. The City's sewer system provides wastewater service to approximately 25,000 people, in addition to many commercial and industrial customers. The City's Capital Improvements Program (CIP) has budgeted nearly \$1.4 million for sewer capacity improvements in accordance with the state Water Board-required Sewer System Management Plan (SSMP), which identified \$10.7 million in sewer maintenance and improvement costs.

In addition, the CIP foresees projects to improve roads, sidewalks and landscaping, in conjunction with water, sewer, and storm drain infrastructure, in accordance with the state Water Board-required Storm Water Pollution Prevention Plan (SWPPP), as well as traffic safety, parks and facilities.

Multiple factors have affected the City's sewer infrastructure including decades of deferred maintenance, the need to implement a Fats, Oils, and Greases Control Plan, and the need to design and upgrade the existing system to meet deficient capacity and accommodate growth. Insufficient sewer capacity can cause sewage backups into homes, and sewage poses a significant threat to human health. The City must complete its system-wide inspection, assessment, and any required sewer capacity improvements before the approval of more multiple family dwelling projects places further demands on the system. Approving new multi-unit projects before this work is accomplished would create greater uncertainty as it relates to project related impacts to our sewer system, and as such presents a current and immediate threat to health and safety.

Multiple factors also affect the City's continued access to sufficient water supply which comes from local groundwater and imported water. Reliability of the City's water supply is based on the capacity and condition of infrastructure. Such conditions are affected by, among other things: groundwater contaminants, water well maintenance, and years of deferred maintenance, in general. Furthermore, reliable water supply is impacted by seasonal demand

affected by drought, and by population growth under land use regulations, including those in the Specific Plan and proposed amendments.

Deferred maintenance of the City's street infrastructure have resulted in repairs totaling approximately \$17.8 million. The average citywide roadway conditions are rated Good with slight distress and weathering, while 32 percent of streets have an overall pavement condition rating of below 55, which is Fair with moderate distress and/or severe weathering. Hence, any further demand on the City's roadways from new multiple family dwelling projects requires further analysis, and development and consideration of mitigation measures, impact fees, and short and long-term planning to maintain and reduce deterioration of the City's roadways.

The City Council finds that the establishment of new multiple family development within the City, before the City has completed its analysis of the current state of the City's infrastructure, presents a current and immediate threat to health and safety.

The approval of additional permits or other land use entitlement for new multi-unit residential development would result in that threat to public health, safety, or welfare because, without the benefit of new regulations and engineering and planning practices in place (e.g. impact fees and mitigation measures), the demands of the new development threaten to harm or overwhelm the City's infrastructure. This includes roads, traffic controls, water, sewer, and storm drains.

B. The continued approval of the development of multiple-family housing projects would have a specific, adverse impact upon the public health or safety:

The continued approval of the development of multiple-family dwelling projects have the potential to strain public safety, schools, roads, water and sewers in the City in the absence of adequate analysis of the state of the City's infrastructure and need for additional public facilities. The demands of new development threaten to harm or overwhelm the City's infrastructure. This includes roads, traffic controls, water, sewer, and storm drains, which are or will be improved as part of the CIP.

Insufficient sewer capacity can cause sewage backups into homes, and sewage poses a significant threat to human health. In addition, insufficient water supply may result in lack of emergency water services to fight fires and limits citywide access to potable water for residential, commercial and industrial uses.

Overall infrastructure capacity may be further exacerbated by new approvals of multiple-family dwelling projects before the City has completed its assessment and repair of the sewer, water, and street systems and can implement new development impact fees, and improve standards that mitigate impacts on these types of infrastructure.

C. This interim moratorium is necessary to mitigate or avoid the specific, adverse impact identified above:

The City Council finds that a temporary moratorium on the application filing, processing, approval and issuance of permits for multiple-family dwellings is necessary to allow the City sufficient time to study and develop comprehensive regulations, mitigation measures, and engineering and planning practices that will balance development with infrastructure capacity and other public facilities.

When a city prepares to adopt new development regulations, there is the risk of a rush of new development applications in an attempt to beat the new regulations. The moratorium on multi-unit residential development permits, while the City studies and updates its current regulations, would prevent such applications from defeating the purpose of any new regulations the City may consider.

D. There is no feasible alternative to satisfactorily mitigate or avoid the specific, adverse impact identified above as well or better, with a less burdensome or restrictive effect, than the adoption of the proposed interim moratorium:

This moratorium will afford the City a reasonable amount of time to complete its analysis of the state of the City's infrastructure, determine the need for additional public facilities to accommodate future development, and develop appropriate potential regulations, mitigation measures, and impact fees commensurate with the demands of the new development.

Faced with the choice of allowing new multi-unit residential development to proceed without the benefit of this vital analysis, or suspending such approvals for the term of this moratorium, the City finds that only the proposed suspension will mitigate or avoid the specific, adverse impacts identified in the findings above. Accordingly, the City Council finds that there is no feasible alternative to this interim moratorium.

SECTION 7. CEQA. This Urgency Ordinance is exempt from the California Environmental Quality Act ("CEQA") based on the following:

A. This Urgency Ordinance is not a "project" within the meaning of Section 15378 of the CEQA Guidelines as it has no potential for resulting in a physical change in the environment, either directly or indirectly.

B. This Urgency Ordinance is categorically exempt from CEQA under Section 15306 of the CEQA Guidelines, as it provides for basic data collection and research regarding the City's infrastructure and development regulations, and is limited to information gathering leading to an action which the City has not yet approved or funded.

C. This Urgency Ordinance is categorically exempt from CEQA under Section 15308 of the CEQA Guidelines, as it is a regulatory action by the City and authorized by the Zoning Ordinance and Government Code Section 65858 to assure the maintenance and protection of the environment and adoption of contemplated legislation, regulation, and policies.

D. This Urgency Ordinance is not subject to CEQA under the general rule set forth in Section 15061(b)(3) of the CEQA Guidelines that CEQA only applies to projects which have the

potential for causing a significant effect on the environment. For the reasons described above, it can be seen with certainty that there is no possibility that this Urgency Ordinance will have a significant effect on the environment.

SECTION 8. Severability. If any section, subsection, subdivision, paragraph, sentence, clause or phrase of this Urgency Ordinance, or any part thereof is for any reason held to be invalid or unconstitutional by a decision of any court of competent jurisdiction, such decision shall not affect the validity of the remaining portions of this Urgency Ordinance or any part thereof. The City Council hereby declares that it would have passed each section, subsection, subdivision, paragraph, sentence, clause or phrase thereof, irrespective of the fact that any one or more section, subsection, subdivision, paragraph, sentence, clause or phrase would be subsequently declared invalid or unconstitutional.

SECTION 9. Effective Date. Pursuant to Government Code section 36937, this Urgency Ordinance shall become effective immediately upon adoption if adopted by at least four-fifths vote of the City Council and shall be in effect for 45 days from the date of adoption unless extended by the City Council as provided for in Government Code section 65858.

PASSED, APPROVED, AND ADOPTED by the City Council of the City of San Fernando at its regular meeting on this 7th day of December, 2015.

Joel Fajardo, Mayor

ATTEST:

Elena G. Chávez, City Clerk

APPROVED AS TO FORM:

Rick R. Olivarez, City Attorney

STATE OF CALIFORNIA)
COUNTY OF LOS ANGELES) **SS.**
CITY OF SAN FERNANDO)

I, ELENA CHÁVEZ, City Clerk of the City of San Fernando, do hereby certify that the foregoing Ordinance was adopted a regular meeting of the City Council held on the 7th day of December, 2015, and was carried by the following roll call vote:

AYES:

NOES:

ABSTAIN:

ABSENT:

Elena G. Chávez, City Clerk

*This Page
Intentionally
Left Blank*

*This Page
Intentionally
Left Blank*



AGENDA REPORT

To: Mayor Joel Fajardo and Councilmembers

From: Brian Saeki, City Manager
By: Chris Marcarello, Deputy City Manager/Public Works Director

Date: December 7, 2015

Subject: Review of Transit Services for Development of Transit Service Provider Request for Proposals (RFP)

RECOMMENDATION:

It is recommended that the City Council review and provide comments related to key components of the City's Transportation Program.

BACKGROUND:

1. On May 19, 2008, the City Council awarded a five-year contract to First Transit, Inc. for the maintenance and operation of the City's transit related services.
2. On June 2, 2013, the City Council approved a two-year contract extension with First Transit, Inc.
3. On May 18, 2015, the City Council approved a one-year contract extension with First Transit, Inc.

ANALYSIS:

The City of San Fernando offers residents a public transportation program that includes curb-to-curb and fixed route trolley services. The existing contract with the City's transportation contractor is scheduled to end on June 4, 2016. As such, it is appropriate for the City to develop an RFP document relative to transportation services. Prior to developing the RFP, it is requested that the City Council provide direction relative to several key components of the RFP, including service levels, on-time performance, vehicles, and other related items. This information will be used to develop an RFP document for public release in January 2016.

Review of Transit Services for Development of Transit Service Provider Request for Proposals (RFP)Page 2 of 5

Current Contractor

First Transit Inc. provides fixed route and demand responsive services for San Fernando residents. This includes the management and operation of the City's Dial-A-Ride and Trolley service as well as the maintenance of all transit vehicles.

San Fernando Dial-A-Ride

The San Fernando Dial-A-Ride (Mission City Transit) provides primarily advance-reservation, curb-to-curb demand responsive transportation to senior residents age 60 and above and individuals with disabilities. There are two buses available and each one can hold up to 14 passengers and two wheel chairs. A request for service may be made up to 14 days in advance of the service day or may be set up as recurring appointments for trips made for the same day and time each week (i.e. doctor's appointments, grocery shopping trips). Same day and immediate trip requests are accommodated if capacity is available.

Fares (one-way):

- Seniors 60 and over \$0.50
- Disabled \$0.50
- General Public \$0.75

Dial-A-Ride service operates the following days and hours:

- Weekdays (Monday – Friday); 7:30 am – 5:00 pm

Dial-A-Ride does not operate on Saturdays, Sundays, or the following National Holidays:

- New Year's Day;
- Easter Sunday;
- Memorial Day;
- Fourth of July;
- Labor Day;
- Thanksgiving Day; or
- Christmas Day.

City policy allows anyone to ride anywhere within the City. But only residents of the City of San Fernando may use Dial-A-Ride for transportation to approved medical sites outside City limits.

San Fernando Trolley

The San Fernando Trolley is a general public, community fixed route service operating on a single route through the City.

Review of Transit Services for Development of Transit Service Provider Request for Proposals (RFP)Page 3 of 5

Trolley services operate the following days and hours:

- Weekdays (Monday – Friday); 10:00 am – 4:00 pm
- Weekends (Saturday and Sunday); 11:00 am – 4:00 pm

City Policy requires that trolley services operate year-around, with the exception of New Year's Day; Easter Sunday; Memorial Day; Fourth of July; Labor Day; Thanksgiving Day; Christmas Day. Two trolley vehicles operate while the program is in service. Fares for these services are affordable and straightforward, costing \$0.25 per trip for the general public and no cost for disabled persons and children 5 years of age or younger.

Request for Proposal Timeline and Key Components

The City's existing contract for public transportation services is scheduled to end on June 4, 2016. As such, work has begun relative to the creation of a new RFP document to solicit proposals from transit service providers. As planned, the RFP process would adhere to the following timeline:

- December 2015: Finalize RFP Document
- January 2016: Advertise RFP to Transit Service Providers
- February 2016: Proposals Due
- March 2016: City Council Award of Contract
Notice to Proceed for July 2016 Contract Startup
- July 2016: New Contract Start Date

Prior to developing the RFP document, it is appropriate that the City Council provide direction related to several key components contained in the RFP. These key components are summarized briefly below:

- **Trolley Schedule**

Currently, the Trolley service has 29 stops and operates on a roughly 30 minute cycle through the City. The following items have been identified for further evaluation:

1. The number of existing stops sometimes causes problems with keeping on-time performance, especially during busy morning/afternoon travel times and when only one trolley is in service. In reviewing the existing stop locations, there are several stops that are in close proximity to each other (1-2 blocks) that could be combined to help improve on-time performance of the Trolley system.

Review of Transit Services for Development of Transit Service Provider Request for Proposals (RFP)Page 4 of 5

2. Based on route timing, the Trolley service could include specific pickup times at locations on the hour, every hour. For instance, the Trolley would make stops as following:
 - i. First Street/Maclay Avenue stop at 11 am, 12 pm, 1 pm, etc.
 - ii. Foothill Boulevard stop at 11:10 am 12:10 pm, 1:10 pm, etc.
 - iii. San Fernando Road stop at 11:20 am, 12:20 pm, 1:20 pm, etc.
 3. The new RFP/Contract should require that the transportation contractor track on-time performance levels in order to gauge system performance.
- Trolley Vehicles

The existing trolleys were purchased in 2008 and are reaching the end of their useful life. In the past few years, these vehicles have been placed out of service for and estimated 288 days due to necessary repairs/maintenance. The trolleys were originally purchased as part of a Federal grant at a cost of approximately \$165,995 per vehicle.

As proposed, the trolleys will be used in the new service contract starting July 2016, however it is unknown how long they will continue to operate properly. Due to the high replacement price and limited available funds for replacement vehicles, the City could look to purchase 18-passenger buses that would be wrapped to look like trolleys (see sample photo below). The cost of these buses is estimated to be \$85,000 per vehicle. Any vehicle/equipment purchases would look to be amortized over the life of the new service agreement.



- Dial-A-Ride Services/Mission City Transit

The Dial-A-Ride services could be further evaluated to determine if possible partnerships (City of Los Angeles, Access Services, and County of Los Angeles) could help

Review of Transit Services for Development of Transit Service Provider Request for Proposals (RFP)Page 5 of 5

to expand on transportation services for our residents.

- Miscellaneous Items

It may be worthwhile for the City to explore possible programs and partnerships that further enhance our transportation programs. These include:

- National Transit Database – Reporting local transportation statistics to the Federal Transportation Administration. This reporting is typically managed by a transit contractor and allows agencies to access additional local return monies for participating in the reporting program.
- Service Enhancements – Consider future route enhancement options to local college campuses or neighboring communities, should grant monies become available.

BUDGET IMPACT:

There is no budget impact at this time. City staff will initiate the development of an RFP document based on input received from the City Council.

CONCLUSION:

The existing transit services contractor is currently providing first-rate public transit services in the City. That said, it is in the best interest of the City to go through the RFP process to make sure all options available for transit related services are known and fully reviewed.

*This Page
Intentionally
Left Blank*

13

*This Page
Intentionally
Left Blank*



AGENDA REPORT

To: Vice Mayor Ballin and Councilmembers

From: Joel Fajardo, Mayor

Date: December 7, 2015

Subject: Consideration to Submit an Application for the Food Insecurity Nutrition Incentive Grant Program and Potential Implementation of a Farmer's Market

RECOMMENDATION:

It is recommended that the City Council provide staff with direction related to applying for the Food Insecurity Nutrition Incentive (FINI) Grant Program.

BACKGROUND:

1. In early November 2015, City staff and I met with the California Center for Public Health Advocacy (CCPHA) to discuss the potential collaboration to submit a grant application to receive Food Insecurity Nutrition Incentive (FINI) funds to implement a healthy corner and farmer's market program in the City of San Fernando.
2. On November 16, 2015, the City Council approved the concept and directed staff to work with CCPHA to submit the grant on behalf the City.
3. During the week of November 23, 2015, the CCPHA notified City staff that they would no longer be able to provide assistance writing the FINI grant.
4. On December 1, 2015, City staff met with Evan Brooks and Associates to discuss grant writing services for other projects including the FINI grant by the December 16, 2015 deadline.

ANALYSIS:

Food Insecurity Nutrition Incentive (FINI) Grant Program

The FINI Grant Program is a program of the United States Department of Agriculture that supports projects to increase the purchase of fruits and vegetables among low-income

Consideration to Submit an Application for the Food Insecurity Nutrition Incentive Grant ProgramPage 2 of 3

consumers participating in the Supplemental Nutrition Assistance Program (SNAP) by providing incentives at the point of purchase. There are three categories of projects:

1. FINI Pilot Projects (awards not to exceed a total of \$100,000 over one year);
2. Multi-year, community-based FINI Projects (awards not to exceed a total of \$500,000 over no more than four years); and
3. Multi-year, FINI Large-Scale Projects (awards of \$500,000 or more over no more than four years).

Grantees are to conduct a project assessment and cooperate with and contribute to independent evaluations to determine the relative effectiveness of the grant program in achieving the legislative goals of “increasing fruit and vegetable purchases” and “improving the nutrition and health status” of participating households (Food, Conservation, and Energy Act of 2008, § 4405(b)(4)(A)). NIFA anticipates the amount available for grants under this program in Fiscal Years 2014 and 2015 will total up to \$31.5 million.

Proposed Project

The three year project for the FINI Grant is designed to increase the purchase of fruits and vegetables among low-income consumers in the City of San Fernando. It would be in conjunction with the Supplemental Nutrition Assistance Program (SNAP) that provides incentives at the point of purchase. The project will focus on collaborating with local partners, including corner market store owners to improve their markets healthy retail environment by promoting healthy foods (fruits, vegetables, water, etc.) instead of unhealthy foods (alcohol, sweetened drinks, soda, candy, chips, etc.). In addition, it is proposed to bring in a farmers market into the City of San Fernando to provide SNAP eligible residents access fresh fruits and vegetables.

Grant Writing Assistance

Evan Brooks Associates has preliminarily agreed to assist the City in preparing and submitting the FINI grant on behalf of the City of San Fernando at no charge.

BUDGET IMPACT:

There is no impact to the Fiscal Year 2015-2016 General Fund budget. All costs associated with the project will be paid through the Food Insecurity Nutrition Incentive Grant Program. However, City staff time will be required to manage the grant and sub-contractors required to implement the scope of work.

Consideration to Submit an Application for the Food Insecurity Nutrition Incentive Grant ProgramPage 3 of 3

CONCLUSION:

The FINI grant will provide the City with needed funding to increase access to fruits and vegetables among low-income residents of the City of San Fernando. It is recommended the City Council provide staff direction as it relates to applying for the Food Insecurity Nutrition Incentive (FINI) Grant Program in light of the recent changes in partnership.

ATTACHMENT:

- A. Food Insecurity Nutrition Incentive Grant Program

Food Insecurity Nutrition Incentive (FINI) Grant Program

2016 Request for Applications (RFA)

APPLICATION DEADLINE: December 16, 2015

ELIGIBILITY: See Part III, A of RFA



United States
Department of
Agriculture

National Institute
of Food and
Agriculture

NATIONAL INSTITUTE OF FOOD AND AGRICULTURE; U.S. DEPARTMENT OF AGRICULTURE

Food Insecurity Nutrition Incentive (FINI) Grant Program

INITIAL ANNOUNCEMENT

CATALOG OF FEDERAL DOMESTIC ASSISTANCE: This program is listed in the Catalog of Federal Domestic Assistance under **10.331**.

DATES: Applications must be received by **5:00 p.m. Eastern Time on December 16, 2015**. Applications received after this deadline will normally not be considered for funding (see Part IV, C. of this RFA). Comments regarding this request for applications (RFA) are requested within 6 months from the issuance of this notice. Comments received after that date will be considered to the extent practicable.

STAKEHOLDER INPUT: The National Institute of Food and Agriculture (NIFA) seeks your comments about this RFA. We will consider the comments when we develop the next RFA for the program, if applicable, and we'll use them to meet the requirements of section 103(c)(2) of the Agricultural Research, Extension, and Education Reform Act of 1998 (7 U.S.C. 7613(c)(2)). Submit written stakeholder comments by the deadline set forth in the DATES portion of this Notice via e-mail to: Policy@nifa.usda.gov. (This e-mail address is intended only for receiving comments regarding this RFA and not requesting information or forms.) In your comments, please state that you are responding to the **Food Insecurity Nutrition Incentive (FINI) Grant Program RFA**.

EXECUTIVE SUMMARY: NIFA requests applications for the **Food Insecurity Nutrition Incentive (FINI) Grant Program** for fiscal year (FY) **2016** to support projects to increase the purchase of fruits and vegetables among low-income consumers participating in the Supplemental Nutrition Assistance Program (SNAP) by providing incentives at the point of purchase. Applications are requested in each of the following three categories: (1) FINI Pilot Projects (awards not to exceed a total of \$100,000 over one year); (2) Multi-year, community-based FINI Projects (awards not to exceed a total of \$500,000 over no more than four years); and (3) Multi-year, FINI Large-Scale Projects (awards of \$500,000 or more over no more than four years). Grantees will be expected to conduct a project assessment and to cooperate with and contribute to an independent evaluation to determine the relative effectiveness of the grant program in achieving the legislative goals of "increasing fruit and vegetable purchases" and "improving the nutrition and health status" of participating households (Food, Conservation, and Energy Act of 2008, § 4405(b)(4)(A)). The appropriated amount available for NIFA to support this program in FY **2016** is approximately **\$16.8 million**. This RFA is being released prior to the passage of an appropriations act for FY 2016. Enactment of additional continuing resolutions or an appropriations act may affect the availability or level of funding for this program.

This notice identifies the objectives for **FINI** projects, the eligibility criteria for projects and applicants, and the application forms and associated instructions needed to apply for a FINI

grant. A webinar reviewing these RFA proposal and match requirements will be held on **October 14th, 2015 at 2:00 p.m. Eastern Time for potential applicants.**

The webinar can be accessed here: <http://nifa-connect.nifa.usda.gov/finip/>

The webinar will be recorded and posted to the FINI webpage, accessible here: <http://nifa.usda.gov/program/food-insecurity-nutrition-incentive-fini-grant-program>

Table of Contents

PART I—FUNDING OPPORTUNITY DESCRIPTION.....	5
A. Legislative Authority and Background.....	5
B. Purpose and Priorities.....	5
C. Program Area Description.....	8
 PART II—AWARD INFORMATION.....	 12
A. Available Funding.....	12
B. Types of Applications.....	12
C. Project Types.....	12
 PART III—ELIGIBILITY INFORMATION.....	 14
A. Eligible Applicants.....	14
B. Cost Sharing or Matching.....	15
 PART IV—APPLICATION AND SUBMISSION INFORMATION.....	 17
A. Electronic Application Package.....	17
B. Content and Form of Application Submission.....	18
C. Submission Dates and Times.....	27
D. Funding Restrictions.....	28
E. Other Submission Requirements.....	30
 PART V—APPLICATION REVIEW REQUIREMENTS.....	 31
A. General.....	31
B. Evaluation Criteria.....	31
C. Conflicts of Interest and Confidentiality.....	33
D. Organizational Management Information.....	33
E. Application Disposition.....	34
 PART VI—AWARD ADMINISTRATION.....	 35
A. General.....	35
B. Award Notice.....	35
C. Administrative and National Policy Requirements.....	36
D. Expected Program Outputs and Reporting Requirements.....	36
 PART VII—AGENCY CONTACT.....	 37
 PART VIII—OTHER INFORMATION.....	 38
A. Access to Review Information.....	38
B. Use of Funds; Changes.....	38
C. Confidential Aspects of Applications and Awards.....	39
D. Regulatory Information.....	39
E. Definitions.....	39

PART I—FUNDING OPPORTUNITY DESCRIPTION

A. Legislative Authority and Background

The Food Insecurity Nutrition Incentive (FINI) Grants Program is authorized by section 4208 of the Agricultural Act of 2014, which amends section 4405 of the Food, Conservation, and Energy Act of 2008 (“FCEA”) (7 U.S.C. 7517). The authority to administer this program was delegated to the Director of NIFA through the Under Secretary for Research, Education, and Economics (REE). See 79 FR 44101 (July 30, 2014), available at <http://www.gpo.gov/fdsys/pkg/FR-2014-07-30/pdf/2014-17352.pdf>. In FY 2016, it is anticipated that up to \$16,800,000 will be available for grants under this program.

B. Purpose and Priorities

The FINI RFA directly aligns with Strategic Goal 4.2 of the USDA Strategic Plan, which is to Promote Healthy Diet and Physical Activity Behaviors.

The FINI RFA also aligns with the USDA Research, Education, and Economics (REE) Action Plan and specifically addresses Goal 4, Nutrition and Childhood Obesity by strengthening established strategic partnerships and strengthening implementation practices to encourage healthy eating and physical activity at the individual and community levels, focusing on high-risk groups and also advances

The FINI RFA specifically addresses NIFA’s “Strategic Goal 1 (Science), by combating childhood obesity by ensuring the availability of affordable, nutritious food and providing individuals and families science-based nutritional guidance (Subgoal 1.5).”

The primary goal of the FINI grants program is to fund and evaluate projects intended to “increase the purchase of fruits and vegetables by low-income consumers participating in Supplemental Nutrition Assistance Program (SNAP) by providing incentives at the point of purchase” (FCEA, § 4405(b)(2)(A)(ii)(II)). For FINI grants, NIFA defines “fruits and vegetables” as “any variety of fresh, canned, dried, or frozen whole or cut fruits and vegetables without added sugars, fats, or oils, and salt (i.e. sodium).” The program will test strategies that could contribute to our understanding of how best to increase the purchase of fruits and vegetables by SNAP participants to inform future efforts, and develop effective and efficient benefit redemption technologies.

The Act requires the Secretary to conduct an independent evaluation of funded projects, to measure the impact of projects on: “improving the nutrition and health status of participating households receiving incentives” and “increasing fruit and vegetable purchases in participating households.”

Incentivizing purchases of fruits and vegetables increases their affordability and consumption. For example, USDA recently completed an evaluation of the Healthy Incentives Pilot (HIP), which investigated the impact of making fruits and vegetables more affordable to SNAP participants. Under HIP, SNAP households received 30 cents deposited directly back onto their

Electronic Benefit Transfer (EBT) card to be spent on any SNAP-eligible food or beverage for every SNAP dollar they spent on targeted fruits and vegetables at participating SNAP-authorized retailers including large supermarkets, grocery stores and farmers markets. This pilot operated in Hampden County MA between November 2011 and December 2012. A rigorous evaluation showed that HIP significantly increased the consumption of targeted fruits and vegetables and this increased consumption was on the order of about one quarter of a cup per day. The final evaluation report is available online at <http://www.fns.usda.gov/healthy-incentives-pilot-final-evaluation-report>.

Grantees that receive both FINI and SNAP-Ed funds:

- While SNAP-Ed providers are encouraged to form partnerships and collaborations in order to leverage resources, SNAP-Ed funds may not be used to provide actual cash or other financial incentives.
- SNAP-Ed funds can be used for policy, systems and environmental change interventions, such as working with retailers on fruit and vegetable product placement, and social marketing in addition to educational efforts at venues such as Farmers Markets, Senior Centers, Child Care locations etc.

All FINI projects must (1) have the support of the State agency responsible for the administration of SNAP; (2) increase the purchase of fruits and vegetables by low-income consumers participating in SNAP by providing incentives at the point of purchase; (3) operate through authorized SNAP retailers, and in compliance with all relevant SNAP regulations and operating requirements; (4) agree to participate in the FINI comprehensive program evaluation; (5) ensure that the same terms and conditions apply to purchases made by individuals with SNAP benefits and with incentives under the FINI grants program as apply to purchases made by individuals who are not members of households receiving benefits as provided in 7 CFR. 278.2(b); and (6) include effective and efficient technologies for benefit redemption systems that may be replicated in other States and communities.

The term “incentive” means any financial or non-financial inducements that would increase the purchase and consumption of eligible fruits and vegetables by SNAP clients.

- Examples of allowable financial incentives include, but are not limited to, vouchers redeemable for eligible fruits and vegetables; other SNAP-eligible items received for having purchased fruits and vegetables; and direct point-of-sale discounts on eligible fruits and vegetables.
- Examples of allowable non-financial incentives include, but are not limited to, giveaways of eligible fruits and vegetables; and nutrition education.
- Examples of unallowable incentives include, but are not limited to, giveaways of alcohol, tobacco, firearms, and lottery tickets.

Incentives that are not allowed may not be paid for with either Federal or matching funds. In addition, the cost of incentives must be allowable under the applicable cost principles in 2 CFR part 200, Subpart E.

Priority will be given to grant proposals with incentives that are most likely to directly and efficiently increase the purchase and consumption of eligible fruits and vegetables by SNAP clients. Any grant proposal that includes non-financial incentives will be subject to additional scrutiny prior to approval, and would need to explain clearly how it contributes to the overall objectives of this program. In general, USDA expects non-financial incentives, if used, to be supplemental to a strong financial-based incentive.

Note: Because the statutory language of the 2014 Farm Bill requires FINI grantees to provide incentives specifically to SNAP clients, the equal treatment provision of 7 CFR 278.2(b) does not apply to FINI grantees for the purpose of providing incentives under the FINI grants.

In reviewing applications submitted in response to this RFA, and depending on the type of FINI project (as described in further detail in Part I, C.1, C.2, and C.3), NIFA will give priority to projects that:

- Maximize the share of funds used for direct incentives to participants;
- Test innovative or promising strategies that would contribute to our understanding of how best to increase the purchase of fruits and vegetables by SNAP participants, that would inform future efforts;
- Develop innovative or improved benefit redemption systems that could be replicated or scaled;
- Use direct-to-consumer sales marketing;
- Demonstrate a track record of designing and implementing successful nutrition incentive programs that connect low-income consumers and agricultural producers;
- Provide locally or regionally produced fruits and vegetables (as defined in Subpart VIII (E) of this document), especially culturally appropriate fruits and vegetables for the target audience; and
- Are located in underserved communities, particularly Promise Zones and StrikeForce communities (see Part VIII, E for more information).

FINI projects present the opportunity to bring together stakeholders from the distinct parts of the food system and to foster understanding of how they might improve the nutrition and health status of participating households receiving incentives to purchase fruits and vegetables. FINI projects are also intended to address the development of effective and efficient technologies for benefit redemption that are replicable by others.

NIFA is soliciting applications for the FINI under the following areas:

C. Program Area Description

NIFA is soliciting applications for three (3) types of grants: (1) FINI Pilot Projects (FPP); (2) FINI Projects (FP); and (3) FINI Large Scale Projects (FLSP).

1. FINI Pilot Projects (FPP)

Funding Level: Awards not to exceed \$100,000.

Period of Performance: Project period is not to exceed one year.

Program Code: FPP

FINI Pilot Projects (FPP) support the development of projects with an infusion of Federal dollars to pilot innovative strategies to increase the purchase of fruits and vegetables (as defined in Subpart VIII (E) of this document) by low-income consumers participating in SNAP by providing incentives at the point of purchase. FPPs must have the support of the State SNAP agency, operate through authorized SNAP retailers, and comply with all relevant SNAP regulations and operating requirements. FPPs are aimed at new entrants seeking funding for a project in the early stages of incentive program development. The project should be designed to create community-based food incentive projects with objectives, activities, and outcomes that are in alignment with the FINI grants program's primary goals. Preference will be given to pilot projects that include one or more of the following:

- (i) Maximize the share of funds used for direct incentives to participants;
- (ii) Test innovative or promising strategies that would contribute to our understanding of how best to increase the purchase of fruits and vegetables by SNAP participants, to inform future efforts;
- (iii) Develop innovative or improved benefit redemption systems that could be replicated or scaled;
- (iv) Use direct-to-consumer sales marketing;
- (v) Provide locally or regionally produced fruits and vegetables, especially culturally appropriate fruits and vegetables for the target audience; and/or
- (iv) Are located in underserved communities, particularly Promise Zones and StrikeForce communities.

Examples of FPPs include, but are not limited to, innovative strategies working at point of purchase with SNAP authorized retailers, including food stores, market stands, farmers' markets, community supported agriculture programs (CSAs), marketing and consumer cooperatives, and other SNAP authorized retailers

Project Self-Evaluation. All projects must involve SNAP participants. All FPPs must submit a project proposal that includes a method of evaluating the success of the program in developing a

viable project. Because FINI Pilot Projects are in the earliest stages of development and would not offer a fair test of effectiveness, they will only be required to submit limited information and data for the comprehensive program evaluation that will inform the Department of potential new strategies and promising new programs to consider in future funding cycles. FPP grantees will be required to provide their self-assessment data to the independent evaluation contractor. Project assessments must follow USDA guidelines to ensure an appropriate level of comparability of methods, outcomes, and measures.

2. FINI Projects (FP)

Funding Level: Awards not to exceed \$500,000.

Period of Performance: Project period is not to exceed four (4) years

Program Code: FIP

FINI Projects (FP) support the development and evaluation of projects to increase the purchase of fruits and vegetables (as defined in Subpart VIII (E) of this document) by low-income consumers participating in SNAP by providing incentives at the point of purchase. The projects will test strategies that could increase the purchase of fruits and vegetables by SNAP participants to inform future efforts, and develop effective and efficient benefit redemption technologies.

FPs should be designed to create or support local community-based food projects with objectives, activities, and outcomes that are in alignment with the FINI grants program's primary goals. FPs are aimed at mid-sized groups developing incentive programs at the local or State level; organizations in this category are typically not new to implementing such programs, although projects are required to expand the breadth, scope or reach of these programs, rather than supplant current program resources. FPs are not in the pilot stages of development and should have established relationships with necessary partners and collaborators. FPs must have the support of the State SNAP agency, operate through authorized SNAP retailers, and comply with all relevant SNAP regulations and operating requirements. Preference will be given to projects that include one or more of the following:

- (i) Maximize the share of funds used for direct incentives to participants;
- (ii) Test innovative or promising strategies that would contribute to our understanding of how best to increase the purchase of fruits and vegetables by SNAP participants, to inform future efforts;
- (iii) Develop innovative or improved benefit redemption systems that could be replicated or scaled;
- (iv) Use direct-to-consumer sales marketing;
- (v) Demonstrate a track record of designing and implementing successful nutrition incentive programs that connect low-income consumers and agricultural producers;

- (vi) Provide locally or regionally produced fruits and vegetables, especially culturally appropriate fruits and vegetables for the target audience; and/or
- (vii) Are located in underserved communities, particularly Promise Zones and StrikeForce communities.

Examples of FPs include, but are not limited to, innovative strategies working at point of purchase with SNAP authorized retailers, including food stores, market stands, farmers' markets, CSAs, marketing and consumer cooperatives, and other SNAP authorized retailers.

Project Self-Evaluation. All FPs must involve SNAP participants and include an evaluation of whether the project met its goals and objectives. Project evaluations must follow USDA guidelines to ensure an appropriate level of comparability of methods, outcomes, and measures. All FPs will also be required to cooperate with and contribute to an independent evaluation contractor conducting the comprehensive program evaluation.

3. FINI Large Scale Projects (FLSP)

Funding Level: Awards of \$500,000 or greater

Period of Performance: Project period is not to exceed four (4) years

Program Code: FLSP

The primary purpose of the FINI Large Scale Projects (FLSP) is to develop and evaluate projects to increase the purchase of fruits and vegetables (as defined in subpart VIII (E) of this document) by low-income consumers participating in SNAP by providing incentives at the point of purchase, using effective and efficient benefit redemption technologies. The projects will test strategies that could contribute to our understanding of how best to increase the purchase of fruits and vegetables by SNAP participants to inform future efforts.

FLSP should be designed to create or support multi-county, State-wide and regional incentive programs. FLSP should be coordinated food projects with objectives, activities, and outcomes that align with the FINI grants program's primary goals. Projects must have the support of the State SNAP agency, operate through authorized SNAP retailers, and comply with all relevant SNAP regulations and operating requirements. Projects are required to expand the breadth, scope or reach of these programs, rather than supplant current program resources. Preference will be given to projects that include one or more of the following:

- (i) Maximize the share of funds used for direct incentives to participants;
- (ii) Test innovative or promising strategies that would contribute to our understanding of how best to increase the purchase of fruits and vegetables by SNAP participants, to inform future efforts;
- (iii) Develop innovative or improved benefit redemption systems that could be replicated or scaled;

- (iv) Use direct-to-consumer sales marketing;
- (v) Demonstrate a track record of designing and implementing successful nutrition incentive programs that connect low-income consumers and agricultural producers;
- (vi) Provide locally or regionally produced fruits and vegetables, especially culturally appropriate fruits and vegetables for the target audience; and/or
- (vii) Are located in underserved communities, particularly Promise Zones and StrikeForce communities.

FINI Large Scale Projects include, but are not limited to, innovative strategies working at point of purchase with SNAP authorized retailers, including food stores, market stands, farmers' markets, CSAs, marketing and consumer cooperatives, and other SNAP authorized retailers.

Project Self-Evaluation. All projects must involve SNAP participants and include an evaluation of whether the project met its goals and objectives. Project evaluations must follow USDA guidelines to ensure an appropriate level of comparability of methods, outcomes, and measures. As discussed below, a higher level of rigor will be expected for the FSLP evaluations. All FLSPs will also be required to cooperate with and contribute to an independent evaluation contractor conducting the comprehensive program evaluation.

PART II—AWARD INFORMATION

A. Available Funding

The amount available for NIFA support of this program in FY 2016 is approximately \$16.8 million. The funds will be awarded through a grant. There is no commitment by USDA to fund any particular application or to make a specific number of awards.

Awards issued as a result of this RFA will have designated the Automated Standard Applications for Payment (ASAP) system, operated by the Department of Treasury's Bureau of the Fiscal Service, as the payment system for funds. For more information see <http://fms.treas.gov/index1.html>.

B. Types of Applications

In FY 2016, you may submit applications to the FINI Program:

New application. This is a project application that has not been previously submitted to the FINI Program. We will review all new applications competitively using the selection process and evaluation criteria described in Part V—Application Review Requirements.

Resubmitted application. This is an application that had previously been submitted to the FINI Program but not funded. Project Directors (PDs) must respond to the previous review panel summary (see Response to Previous Review, part IV). Resubmitted applications must be received by the relevant due dates, will be evaluated in competition with other pending applications in appropriate area to which they are assigned, and will be reviewed according to the same evaluation criteria as new applications.

C. Project Types

Applications will be accepted for three (3) project types: (1) FINI Pilot Projects; (2) FINI Projects; and (3) FINI Large-Scale Projects. The FINI grants program will only accept one application across the three project types per project team under this RFA.

1. FINI Pilot Projects (FPP)

FPPs are aimed at new entrants seeking funding for a project in the early stages of incentive program development. Applicants should request a budget commensurate with the proposed project. No single FINI Pilot project (FPP) award shall exceed \$100,000 for the total project period. The maximum FINI Pilot Project award period is one year. Applications that exceed the budgetary guidelines will not be reviewed. All FPP awards will be made on the merit of the proposed project, with budgets considered only after the merits of the project have been determined. NIFA reserves the right to negotiate final budgets with successful applicants.

2. FINI Projects (FP)

FINI Projects are aimed at mid-sized groups developing incentive programs at the local or State level. Applicants should request a budget and project period commensurate with the proposed project. FP proposals should include a budget of no more than \$500,000 for a project period not to exceed four years. Proposal budgets may be less than \$500,000 and/or a proposed project period of less than four years. Applications that exceed budgetary guidelines will not be reviewed.

All FINI awards will be made based on the merit of the proposed project with budgets considered only after the merits of the project have been determined. NIFA reserves the right to negotiate final budgets with successful applicants.

3. FINI Large Scale Projects (FLSP)

FLSPs are aimed at groups developing multi-county, State, and regional incentive programs with the largest target audience of all FINI projects. Applicants should request a budget and project period commensurate with the proposed project. FLSP proposals should include a budget of \$500,000 or more for a project period not to exceed four years. Applicants may submit a proposed project period of less than four years. All FINI awards will be made based on the merit of the proposed project with budgets considered only after the merits of the project have been determined. NIFA reserves the right to negotiate final budgets with successful applicants.

PART III—ELIGIBILITY INFORMATION

A. Eligible Applicants

Applications may only be submitted by government agencies and non-profit organizations. Award recipients may subcontract to organizations not eligible to apply provided such organizations are necessary for the conduct of the project. Failure to meet an eligibility criterion by the time of application deadline may result in the application being excluded from consideration or, even though an application may be reviewed, will preclude NIFA from making an award.

1. FPP, FP, & FLSP Eligible Entity

Eligibility to receive this grant is limited to government agencies and non-profit organizations (FCEA, § 4405(b)(2)(A)). Eligible government agencies and non-profit organizations may include: an emergency feeding organization; an agricultural cooperative; a producer network or association; a community health organization; a public benefit corporation; an economic development corporation; a farmers' market; a community-supported agriculture program; a buying club; a SNAP-authorized retailer; and a State, local, or tribal agency. All applicants must demonstrate in their application that they are a government agency or non-profit organization.

To be eligible to receive a FPP, FP, or FLSP grant, applicants must propose projects that: (1) have the support of the State SNAP agency; (2) would increase the purchase of fruits and vegetables by low-income consumers participating in SNAP by providing incentives at the point of purchase; (3) operate through authorized SNAP retailers, and comply with all relevant SNAP regulations and operating requirements; (4) agree to participate in the FINI comprehensive program evaluation; (5) ensure that the same terms and conditions apply to purchases made by individuals with SNAP benefits and with incentives under the FINI grants program as apply to purchases made by individuals who are not members of households receiving benefits as provided in 7 C.F.R. 278.2(b); and (6) include effective and efficient technologies for benefit redemption systems that may be replicated in other States and communities.

Note: Because the statutory language of the 2014 Farm Bill requires FINI grantees to provide incentives specifically to SNAP clients, the equal treatment provision of 7 CFR 278.2(b) does not apply to FINI grantees for the purpose of providing incentives under the FINI grants.

In addition, applicants must meet the following requirements to receive a FPP, FP, or FLSP grant: (1) have experience in (i) efforts to reduce food insecurity in the community, including food distribution, improving access to services, or coordinating services and programs; or (ii) experience with the SNAP program; (2) demonstrate competency to implement a project, provide fiscal accountability, collect data, and prepare reports and other necessary documentation; (3) secure the commitment of the State SNAP agency to cooperate with the project; and (4) possess a demonstrated willingness to share information with researchers, evaluators (including the independent evaluator for the program), practitioners, and other interested parties, including a plan for dissemination of results to stakeholders.

Projects are encouraged to provide employees with important job skills. Additionally, applicants are encouraged to have experience the following areas: (i) community food work, particularly concerning small and medium-sized farms, including the provision of food to people in low-income communities and the development of new markets in low-income communities for agricultural producers; and (ii) job training and business development activities for food-related activities in low-income communities.

2. Partners and Collaborators

Applicants for FPP, FP, and FLSP awards are encouraged to seek and create partnerships with public or private, non-profit or for-profit entities, including links with academic institutions (including minority-serving colleges and universities) and/or other appropriate professionals; community-based organizations; local government entities; Promise Zone lead applicant/organization or implementation partners; and StrikeForce area coordinators and/or partnering entities for the purposes of providing additional resources and strengthening under-resourced communities. *Only the applicant must meet the requirements specified above for grant eligibility.* Project partners and collaborators need not meet the eligibility requirements. When planning collaborations, see Part III, B. Award recipients may subcontract to organizations not eligible to apply provided such organizations are necessary for the successful completion of the project. See Part IV, D., Funding Restrictions.

Fiscal Agent:

If an institution/organization cannot accept Federal funds directly, a letter must be included in the application stating that in the event the application results in an award, the award funds must be administered through a fiscal agent organization on their behalf. This agent must be identified in the letter from the applicant and the letter must be countersigned by an authorized representative of the fiscal agent organization. The letter should include the fiscal agent's point of contact, address, telephone number, fax number and e-mail address. This letter is to be included as an attachment to Field 12, Other Attachments (Part IV.B.3.c.) of the application. In the event an application is recommended for funding, NIFA will request that both the applicant institution/organization and the fiscal agent organization submit complete management information (see Part V, D.). Include documents showing the organizations non-profit status here.

B. Cost Sharing or Matching

FPP, FP, and FLSP applicants **MUST** provide matching contributions on a dollar-for-dollar basis for all Federal funds awarded. Match must be documented for all project years at the time the application is submitted. FPP, FP, and FLSP grantees may meet the match requirement through cash and/or in-kind contributions, including third-party in-kind contributions fairly evaluated, including facilities, equipment, or services.

The non-Federal share of the funding may come from State government, local government, or private sources. Federal money cannot be used to match. Examples of qualifying matching contributions may include direct costs such as: rent for office space used exclusively for the

funded project; duplication or postage costs; and staff time from an entity other than the applicant for job training or nutrition education.

Note that if an applicant partners with a for-profit entity, the non-Federal share that is required to be provided by the applicant may not include the services of an employee of that for-profit entity, including salaries or expenses covered by that employer. (FCEA, § 4405(b)(1)(c)(ii)).

PART IV—APPLICATION AND SUBMISSION INFORMATION

A. Electronic Application Package

Only electronic applications may be submitted via Grants.gov to NIFA in response to this RFA. We urge you to submit early to the Grants.gov system. For an overview of the Grants.gov application process see <http://www.grants.gov/web/grants/applicants/grant-application-process.html>.

New and Current Users of Grants.gov

Prior to preparing an application, we recommend that the Project Director/Principal Investigator (PD/PI) first contact an Authorized Representative (AR, also referred to as Authorized Organizational Representative or AOR) to determine if the organization is prepared to submit electronic applications through Grants.gov. If not (e.g., the institution/organization is new to the electronic grant application process through Grants.gov), then the one-time registration process must be completed PRIOR to submitting an application. It can take as long as 2 weeks to complete the registration process so it is critical to begin as soon as possible. In such situations, the AR should go to **“Register” in the top right corner of the Grants.gov web page (or go to <http://www.grants.gov/web/grants/register.html>) for information on registering the institution/organization with Grants.gov.** Part II.1. of the NIFA Grants.gov Application Guide contains detailed information regarding the registration process. Refer to item 2. below to locate the “NIFA Grants.gov Application Guide”.

Steps to Obtain Application Package Materials

To receive application materials:

1. You must download and install a version of Adobe Reader compatible with Grants.gov to access, complete, and submit applications. For basic system requirements and download instructions, see <http://www.grants.gov/web/grants/support/technical-support/software/adobe-reader-compatibility.html>. Grants.gov has a test package that will help you determine whether your current version of Adobe Reader is compatible.
2. To obtain the application package from Grants.gov, go to <http://www.grants.gov/web/grants/applicants/apply-for-grants.html>. Under Step 1 click on “Download a Grant Application Package,” and enter the funding opportunity number

Funding Opportunity Number: USDA-NIFA-FINI-005395

in the appropriate box and click “Download Package.” From the search results, click “Download” to access the application package.

Contained within the application package is the “NIFA Grants.gov Application Guide.” This guide contains an introduction and general Grants.gov instructions, information

about how to use a Grant Application Package in Grants.gov, and instructions on how to complete the application forms.

If you require assistance to access the application package (e.g., downloading or navigating Adobe forms) **or submitting the application**, refer to resources available on the Grants.gov website (<http://www.grants.gov/web/grants/applicants/applicant-resources.html>). Grants.gov assistance is also available at:

Grants.gov customer support

800-518-4726 Toll-Free or 606-545-5035

Business Hours: 24 hours a day, 7 days a week. Closed on [federal holidays](#).

Email: support@grants.gov

Grants.gov iPortal (see <https://grants-portal.psc.gov/Welcome.aspx?pt=Grants>):

Top 10 requested help topics (FAQs), Searchable knowledge base, self-service ticketing and ticket status, and live web chat (available 7 a.m. - 9 p.m. ET). Get help now!

Have the following information available when contacting Grants.gov:

- Funding Opportunity Number (FON)
- Name of agency you are applying to
- Specific area of concern

B. Content and Form of Application Submission

You should prepare electronic applications following Parts V and VI of the NIFA Grants.gov Application Guide. This guide is part of the corresponding application package (see Section A. of this Part). The following is **additional information** needed to prepare an application in response to this RFA. **If there is discrepancy between the two documents, the information contained in this RFA is overriding.**

Note the attachment requirements (e.g., PDF) in Part III section 3. of the guide. ANY PROPOSALS THAT ARE NON-COMPLIANT WITH THE REQUIREMENTS (e.g., content format, PDF file format, file name restrictions, and no password protected files) WILL BE AT RISK OF BEING EXCLUDED FROM NIFA REVIEW. Grants.gov does not check for NIFA required attachments or that attachments are in PDF format; see Part III section 6.1 of the guide for how to check the manifest of submitted files. Partial applications will be excluded from NIFA review. We will accept subsequent submissions of an application until close of business on the closing date in the RFA (see Part V, 2.1 of the NIFA Grants.gov Application Guide for further information).

For any questions related to the preparation of an application, review the NIFA Grants.gov Application Guide and the applicable RFA. If assistance is still needed for preparing application forms content, contact:

- Email: electronic@nifa.usda.gov
- Phone: 202-401-5048
- Business hours: Monday through Friday, 7 a.m. – 5 p.m. ET, excluding federal holidays.

1. SF 424 R&R Cover Sheet

Information related to the questions on this form is dealt with in detail in Part V, 2. of the NIFA Grants.gov Application Guide.

2. SF 424 R&R Project/Performance Site Location(s)

Information related to the questions on this form is dealt with in detail in Part V, 3. of the NIFA Grants.gov Application Guide.

3. R&R Other Project Information Form

Information related to the questions on this form is dealt with in detail in Part V, 4. of the NIFA Grants.gov Application Guide.

a. Field 7. Project Summary/Abstract. The summary should also include the relevance of the project to the goals of **FINI grants program**. See Part V. 4.7 of NIFA Grants.gov Application Guide for further instructions and a link to a suggested template.

b. Field 8. Project Narrative.

NOTE: The Project Narrative shall not exceed **10** pages of written text regardless of whether it is single- or double-spaced and up to **5** additional pages for figures and tables. We have established this maximum (15 pages) to ensure fair and equitable competition. The Project Narrative must include all of the following:

1. FINI Pilot Projects, FINI Projects, and FINI Large Scale Projects

The Project Narrative for FINI Pilot Projects (FPPs), FINI Projects (FPs), and FINI Large Scale Projects (FLSPs) must include the headings below in bold followed by the response for each of the points noted below.

(a) The Community to be Involved in the Project and the Needs to be Addressed. Identify and succinctly describe the critical elements and needs of the local food economy or food system, including demographics, income, and geographic characteristics of the area or community to be served and how the community might benefit from an incentive project. Beyond a recitation of statistics, applications should describe local capabilities and assets, such as those identified in a community food assessment, and involvement of low-income communities in the context of project activities and operations.

Most relevant is an explanation of why the applicant and its partners selected the activities proposed in the application. Note the main targets or beneficiaries of the project and the community needs and opportunities being addressed. The needs addressed should directly relate to project goals and objectives described below. It is recommended that this section be no more than one and one-half page.

(b) The Organizations and Communities Involved in the Project. List the organizations and communities to be involved in carrying out the proposed project. Include a description of the relevant experience of each community group or organization, including the applicant

organization that will be involved, and any related project history. Proposals should demonstrate community linkages and coalitions as appropriate. The qualifications of staff involved with the proposed project and/or organizational leadership should reflect the expertise necessary to carry out the proposed project activities or similar types of activities. Specify the degree to which paid and volunteer staff will be utilized. Experience in and connections with the community will be considered as important as academic or professional credentials in this regard.

To the extent practicable ensure that low-income residents are involved in planning; in particular, describe how the communities being served – particularly the targeted residents and organizations have been or will be involved in planning the project and will be engaged in its implementation and evaluation process. Please reference planning activities, assessments, meetings, or other activities that demonstrate community input into key decision-making.

Letters from the key organizations involved in the project, acknowledging their support and contributions, should be provided. A limited number of additional support letters – such as those from farmers or partner organizations, where appropriate, are encouraged to provide evidence of broad community involvement in both planning and future decision-making. All support letters should be attached in Field 12, Other Attachments (See Part IV, B. 3. c., below, Key Organization Support).

(c) Project Goals and Intended Outcomes. List the goals and intended outcomes of the project, and how they contribute to the primary goal of the FINI grants program. Outcomes should describe specific changes or results that will occur as a consequence of the project and that will constitute “success” for the initiative, including a general description of the range of fruits and vegetables that would be incentivized (such as, but not limited to, fresh, canned, or dried forms). Outcomes should be specific, measurable, achievable, realistic, and timely, describe what will be accomplished, and who and how many people, e.g., residents, participants, will benefit. It is recommended that this section be no more than two pages.

(d) Activities to Achieve the Goals. Discuss how the goals and intended outcomes will be achieved and include how the proposed activities comply with the rules and regulations of SNAP. Discuss how the proposed project outcomes will be realized by providing a systematic description of how the most important steps or milestones will be accomplished. Particular attention should be given to existing technical capabilities and any technical solutions that must be developed for goals, objectives, and outcomes to be achieved. In addition to these descriptions, it is recommended that a table of up to three pages be provided with implementation details for these activities, including: (a) specific steps and achievements in planning, implementing, and evaluating; (b) timetables for milestones, and, as relevant; (c) expected numbers of participants involved in each step of the process. Describe how the proposed project will develop effective and efficient technologies for benefit redemption systems that may be replicated and scaled in other States and communities in the future.

(e) Relationship to Program Objectives. Discuss how the project and its proposed outcomes will address the objectives of the FINI grants program as described in Part I., B. Discuss the specific changes that will result among participants or in the communities served that address

these FINI grants program priorities. It is recommended that this section be no more than one page.

(f) Evaluation. Evaluation is a critical purpose of the FINI grant program. By testing and evaluating various methods and technologies to increase the fruit and vegetable purchases and improving the nutrition and health status of participating households through the FINI grant program, NIFA seeks to determine best practices, and the relative effectiveness of various incentive programs as well as benefit redemption methods. The evaluation requirements of the FINI grant program, therefore, include both process (developing and monitoring indicators of progress towards objectives) and outcomes. Recognizing that FINI projects are likely to vary substantially in scale and maturity, and that grantees are likely to vary considerably in evaluation capacity and expertise, the evaluation requirements differ for each of the three grant categories. The FINI grant program requires a project self-evaluation by each grantee and participation in the program evaluation conducted by the independent evaluator.

All FINI Pilot Projects (FPP) must include a process analysis, a self-assessment of their success in developing a viable project. FPPs will document the process, challenges, and success of implementation and operations. Because these projects are in the earliest stages of development that do not offer a fair test of their potential effectiveness, limited information will be reported to the independent evaluator. FPPs must provide preliminary results of their self-assessment in the annual report to NIFA and to the independent evaluation contractor.

All FINI Projects (FP) must include a process analysis, a self-assessment of their success in developing and operating a viable project. FPs will document the process, challenges, and success of implementation and operations. The process assessment should contain enough timely information over the course of the project to improve program outcomes. FPs must provide preliminary results of their self-assessment in the annual report to NIFA and to the independent evaluator. In addition, because of their expected scope, FPs will be required to cooperate with the independent evaluator.

All FINI Large-Scale Projects (FLSP) must include (1) a process assessment that documents the process, challenges, and success of implementation and operations and (2) an outcome assessment that documents the project's effectiveness in increasing fruit and vegetable purchases among SNAP participants. The process assessment should contain enough timely information over the course of the project to measure program outcomes. Preliminary results shall be included in the annual report to NIFA and to the independent evaluation contractor. Outcome self-assessments must follow guidelines developed by the independent evaluation contractor in collaboration with grantees to ensure an appropriate level of comparability of methods, outcomes, and measures. In addition, because of their expected scale and maturity, FLSPs will be required to cooperate with the independent evaluator.

Project Type	Project Self-Evaluation	Comprehensive Program Evaluation (by independent evaluator)
FPP	Process evaluation	<ul style="list-style-type: none"> • Required to participate • Participation includes providing self-assessment information to independent evaluator.
FP	Process evaluation	<ul style="list-style-type: none"> • Required to participate • Contribute to minimum core data set • Collaborate with independent evaluator to identify comparison sites
FLSP	Rigorous self-evaluation (process and outcome)	<ul style="list-style-type: none"> • Required to participate • Contribute to minimum core data set • Collaborate with independent evaluator to identify comparison sites

Comprehensive FINI Program Evaluation (by independent evaluator). The independent evaluation is expected to be based on a cluster evaluation model that builds on the collaboration and coordination of individual project assessments and an overall program evaluation. It is expected to consist of four components: a *process analysis* to describe project implementation and support future replication of successful approaches, an *outcome analysis* to assess the effectiveness of each FP and FSLP, a *comparative analysis* to integrate results across sites and approaches, attempting to answer the question of what works best (and when or where), and *technical assistance* to support consistent implementation of evaluation protocols.

USDA has determined that a comparison group design offers the best balance between the statutory requirement to use “rigorous methodologies capable of producing scientifically valid information” while accommodating the limited administrative and evaluation capacities of potential FPs and FSLPs (FPPs have a limited role in the independent evaluation). This quasi-experimental approach uses a comparison site – such as a neighborhood across town or a group of SNAP participants who are not offered the nutrition incentive – as a baseline to assess the effect of offering an incentive. Outcomes for each group (intervention and comparison) are measured before and again sometime after the nutrition incentive is provided. The independent evaluator – working in collaboration with FPs and FSLPs – will identify groups that are as similar as possible to the intervention communities to make the comparison as fair as possible.

All FPs and FSLPs will be required to cooperate with the independent evaluator by:

- Supporting implementation of evaluation requirements (including but not limited to helping the independent evaluation contractor identify appropriate comparison sites or groups and providing the minimum core data set described below);
- Meeting periodically with staff from NIFA, FNS, the independent evaluation contractor, and other FINI grantees to review project plans, evaluation objectives and methods, data collection and reporting requirements, and analysis and reporting of results;

- Facilitating access to or providing documentation of project implementation, operations, costs, and outcomes; and
- Facilitating site visits and interviews with project staff, partners and program participants.

FPs and FLSPs will be required to periodically provide the independent evaluation contractor a minimum core data set to ensure common program tracking and enable meaningful comparisons across all projects. FPs and FLSPs may choose at their option to collect additional information beyond the minimum core data set as part of their self-assessments; the independent evaluation contractor will also collect additional data, including information on consumer knowledge, attitudes, perceptions, and purchase and consumption behaviors. The minimum core data set includes the following:

Site and Project Information

- Management or organizational structure of the program
- Financial instrument used for SNAP and incentive purchases (tokens, scrip, electronic, etc.)
- Retail locations, mobile routes, or other pertinent information to understand how the project improves access to healthy food for underserved, low-income consumers
- Months of operation and operating days and hours
- Whether it is a new SNAP incentive program or the continuation, expansion, or modification of an existing program
- Whether program sites accept other nutrition assistance program benefits
- Whether program sites collaborate with nutrition education programs or offer other experiential nutrition education activities
- Expenses associated with establishment and operations of the program

Incentive Program Information

- Fruit and vegetable products eligible for incentives
- Incentive level (ratio and maximum)
- Incentive delivery mechanism
- Number of SNAP participants (per site/per year)
- Dollar value of SNAP purchases (per site/per year)
- Number of SNAP transactions (per site/per year)
- Dollar value of incentives issued (per site/per year)
- Dollar value of incentives redeemed (per site/per year)
- Average incentive value redeemed per recipient (weekly/monthly/annually)

Proposals should discuss any opportunities and challenges with the evaluation requirements and how they will be addressed. Proposals should also describe any previous process, outcome, and impact evaluation experience with SNAP participants or other related food programs. The proposal should demonstrate the capacity and willingness to comply with the evaluation requirements.

(g) Specific Program and Incentive Information. Additional important information that must be included in each type of proposal:

- Type of SNAP retailers involved (retail stores, farmers markets, mobile markets, CSAs, etc.)
- Number of months and days that the project, if funded, will operate (e.g. a project at a seasonal farmers market that will operate from June 15 through October 15.)
- Trigger for EARNING the incentive (purchasing fruits or vegetables, purchasing specified fruits and/or vegetables, no purchase necessary, etc.)
- Type of trigger for and the amount of the incentive at different types of retailers
- Products eligible to be PURCHASED or RECEIVED at the point of incentive redemption (all SNAP-eligible foods, all fruits and vegetables, only specified fruits and/or vegetables, etc.)
- Incentive level (percentage discount, ratio, or dollar amount and maximum)
- Financial instrument used for incentive delivery (tokens, scrip, electronic, etc.)
- Indicate if the proposal is a new SNAP incentive program or a continuation, expansion, or modification of an existing program
- Indicate if nutrition education or other interventions will be combined with the incentive
- List where the project and sub-grantee projects will operate
- Indicate if any special waivers will be requested and what the waivers will include
- Indicate if there are any identified retailer participants that still need to be authorized for SNAP, include the store/firm names and locations (or provide the page number (s) in the proposal where these are found)
- Indicate if the project anticipates new retailers that are not currently SNAP authorized, where known, include the store/firm names and locations (or provide the page number(s) in the proposal where these are found)
- Provide the approximate number of retailers, and if specific retailer names, locations, and FNS numbers are known, please provide this information
- Indicate if the project anticipates making any technical enhancements to the retailers, EBT, or other systems. Provide a high-level description of any such proposed technical enhancements and page number(s) in the proposal indicating where a detailed description of technical enhancements is found
- Implementation plan for rollout of incentives across the retailer types that includes anticipated start dates and a plan for communicating changes in implementation schedule to USDA's Food and Nutrition Service and the independent evaluation contractor

Proposals must include this detailed information in Section (g) under the heading "Specific Program and Incentive Information" so the information may be easily pulled out and used by the reviewers and the independent evaluator.

(h) Sustainability. Describe which aspects or components of the project will continue beyond the end of the project period. Discuss how an infusion of Federal funds will be sufficient for the proposed project to advance local capacity-building and achieve sustainability. Projects may identify actual or potential funding sources for continuation of the project. Applicants should differentiate between how the basic elements of the project will be continued versus how the low-income community will be changed and its capacity advanced.

Projects should provide evidence, e.g., a market analysis or the outline of a business plan, to demonstrate that it is likely to become successful in meeting FINI grant program goals. Business plan outlines or any other documentation of evidence for sustainability should be no more than five pages and should be included as an appendix. Such evidence should be included as an Other Attachment, Field 12 (see Part IV.B.3.c.).

(i) Non-supplantation. Grants shall be used to supplement, not supplant, non-Federal funds that would otherwise be available for expenditure on incentive program activities. Grant funds must be used to fund new projects, or expand or enhance existing projects. They may not be used to replace State or local funds that would, in the absence of Federal aid, be available or forthcoming for incentive programs.

c. Field 12. Other Attachments. All attachments must be in PDF format.

- **Key Organization Support.** Attach signed letters from the State SNAP agency and any other key organizations involved in the project acknowledging their support, contributions and commitment; title the attachment ‘Key Organization Support’. Provide evidence of broad community involvement in both planning and decision-making. This section is limited to two page letters of support for each key organization.
- **Matching Funds Documentation.** For **FPP, FP, and FLSP** applicants, this grant program requires applicants to match Federal funds awarded on a dollar-for-dollar basis from non-Federal sources as described in Part III, B. Letters signed by the AR from each source of matching funds are required, and should be attached in Field 12; title the attachment ‘Matching Funds’. Recommended contents of the letter are described below in item 6., R&R Budget (Fed/Non-Fed).
- **Appendices to Project Narrative.** Title the attachment as ‘Appendices’ in the document header and save file as ‘Appendices’. *Appendices to the Project Narrative are allowed if they are directly germane to the proposed project. The addition of appendices must not exceed seven (7) pages and should not be used to circumvent the text and/or figures and tables page limitations.*
- **Logic Model.** Title the attachment as ‘Logic Model’ in the document header and save file as ‘LogicModel’. In order to allow for sufficient evaluation of projects as described, it is recommended that applicants set aside between five and ten percent of the total project budget for evaluation purposes. Applicants should seek the help of academic or other experts in evaluation design and implementation, as appropriate and available. A logic model or chart may also be used. It is recommended that this section be no more than one page. http://www.nifa.usda.gov/about/strat_plan_logic_models.html
- **Fiscal Agent Letter.** See Part III A. 2. If it is necessary to include a fiscal agent letter, then title the attachment as ‘Fiscal Agent’ in the document header and save file as ‘FiscalAgent’. Include documents showing the organizations non-profit status here.

4. R&R Senior/Key Person Profile (Expanded)

Information related to the questions on this form is dealt with in detail in Part V, 5. of the NIFA Grants.gov Application Guide. This section of the Guide includes information about the people who require a Senior/Key Person Profile, and details about the Biographical Sketch and the Current and Pending Support, including a link to a suggested template for the Current and Pending Support.

5. R&R Personal Data – As noted in Part V, 6. of the NIFA Grants.gov Application Guide, the submission of this information is voluntary and is not a precondition of award.

6. R&R Budget

Information related to the questions on this form is dealt with in detail in Part V, 7. of the NIFA Grants.gov Application Guide.

NOTE: For each budget prepared, a budget justification is to be attached to justify costs (both Federal and non-Federal) included in that budget.

Matching.

i. Applicant's Contribution. As stated in Part III, B., matching funds are mandatory for FPPs, FPs, and FLSPs. The R&R Budget ("Fed/Non-Fed") form must be utilized. The applicant's matching support should be shown on the budget in the appropriate categories (salary, materials and supplies, equipment, etc.). **A budget justification (Field K. on the Form) must be included in each budget explaining all Federal and non-Federal costs included therein.**

ii. Third-party Contributions. Each third party contributor should be listed separately under Other Direct Costs (Field F. on the Form) and the amount contributed placed in the "Non-Federal (\$)" column. A detailed breakdown of third-party contributions by donor and budget category should be submitted as an attachment as part of the budget justification (Field K. on the Form). See below.

Proposals should include written verification of commitments of matching support (including both cash and in-kind contributions) from third parties. Letters of commitment for third party matching for the 1st, 2nd, 3rd, and 4th years of multi-year projects must be secured prior to the application submittal. Awards will not be issued until all matching has been verified. Written verification means:

- (a) For any third party cash contributions, a separate pledge agreement for each donation, signed by the authorized representatives of the donor organization and the applicant organization, which must include: (1) the name, address, and telephone number of the donor; (2) the name of the applicant organization; (3) the title of the project for which the donation is made; (4) the dollar amount of the cash donation; (5) a statement that the donor will pay the cash contribution during the grant period; and (6) whether the applicant can designate cash as the applicant deems necessary or the cash contribution has been designated to a particular budget item; and
- (b) For any third party in-kind contributions, a separate pledge agreement (letter of commitment) for each contribution, signed by the authorized representatives of the donor organization and the applicant organization, which must include: (1) the name, address, and telephone number of the

donor; (2) the name of the applicant organization; (3) the title of the project for which the donation is made; (4) a good faith estimate of the current fair market value of the third party in-kind contribution; and (5) a statement that the donor will make the contribution during the grant period.

The sources and amount of all matching support from outside the applicant organization should be summarized on a separate page and attached in the SF 424 (R&R) Other Project Information, Field 12 (Title the attachment “Matching Support”). In addition, each source of non-Federal matching funds must be accompanied by written verification of commitment of matching support (i.e., a signed letter from the AR of the source of matching funds; including both cash and in-kind contributions) from third parties. Include each of these signed matching letters, as attachments, in Field 12 of the SF 424 (R&R) Other Project Information form.

Establish the value of applicant contributions in accordance with applicable cost principles. Refer to 2 CFR Part 200, “Uniform Administrative Requirements, Cost Principles, and Audit Requirements for Federal Awards”, for further guidance and other requirements relating to matching and allowable costs.

7. Supplemental Information Form

Information related to the questions on this form is dealt with in detail in Part VI, 1. of the NIFA Grants.gov Application Guide.

a. Field 2. Program to which you are applying.

Enter the program code name: **FINI Pilot Projects**

Enter the program code: **FPP**

Enter the program code name: **FINI Projects**

Enter the program code: **FIP**

Enter the program code name: **FINI Large Scale Projects**

Enter the program code: **FLSP**

Note that accurate entry of the program code is very important for proper and timely processing of an application.

b. Field 8. Conflict of Interest List. See Part VI, 1.8 of the NIFA Grants.gov Application Guide for further instructions and a link to a suggested template.

C. Submission Dates and Times

Prior to electronic submission of the application via Grants.gov, it is strongly recommended that an administrative review be conducted to ensure that an application complies with all application preparation instructions. An application checklist is included in Part VII of the NIFA Grants.gov Application Guide to assist with this review.

Instructions for submitting an application are included in Part IV, Section 1.9 of the NIFA Grants.gov Application Guide.

Applications must be received by Grants.gov by **5:00 p.m. Eastern Time on December 16, 2015**. Applications received after this deadline will not be considered for funding.

If you have trouble submitting an application to Grants.gov, you should FIRST contact the Grants.gov Help Desk to resolve any problems. Keep a record of any such correspondence. See Part IV. A. for Grants.gov contact information.

We send email correspondence to the AR regarding the status of submitted applications. Therefore, applicants are strongly encouraged to provide accurate e-mail addresses, where designated, on the SF-424 R&R Application for Federal Assistance.

If the AR has not received correspondence **from NIFA** regarding a submitted application within 30 days of the established deadline, contact the Agency Contact identified in Part VII of the applicable RFA and request the proposal number assigned to the application. **Failure to do so may result in the application not being considered for funding by the peer review panel. Once the application has been assigned a proposal number, this number should be cited on all future correspondence.**

D. Funding Restrictions

1. Indirect Costs

Applicants may request full indirect costs, subject to statutory limitations.

In order to do so, the applicant must use the current negotiated indirect cost rate established by its cognizant Federal agency (the agency that provides the most funds). If awarded, the applicant will be required to produce a negotiated indirect cost rate agreement from the cognizant agency in order to recover indirect costs. If unable to obtain a negotiated rate from its cognizant agency, the applicant is not permitted indirect cost reimbursement. Rather, the applicant may only be reimbursed for allowable direct costs. Violation of cost accounting principles is not permitted when re-budgeting or charging costs to awards. Rather, costs must be consistently charged as either indirect or direct costs.

If the applicant wants full indirect costs, but does not have a negotiated rate, and NIFA is the cognizant agency, the applicant must calculate an indirect cost rate in order to request indirect costs. Several sample indirect cost rate calculations are provided on NIFA's indirect cost webpage located at: http://nifa.usda.gov/business/indirect_cost_process.html. During the application process, the applicant is not required to complete the entire indirect cost package identified on NIFA's website. Rather, the applicant need only calculate an indirect cost rate to serve as a basis for requesting indirect costs. If awarded, the applicant will be required to submit a complete Indirect Cost Proposal (ICP) package in order to obtain a negotiated rate as explained on NIFA's indirect cost website.

Applicants may request a 10% de minimis indirect cost rate, subject to statutory limitations.

Applicants who cannot obtain a negotiated rate from their cognizant agency, or who do not wish to go through the negotiation process, may request a 10% de minimis rate if eligible. Applicants who have never received a Negotiated Indirect Cost Rate Agreement (NICRA) are eligible to request a 10% de minimis indirect cost rate.

The 10% de minimis rate should be applied to Modified Total Direct Costs (MTDC). MTDC means all direct salaries and wages, applicable fringe benefits, materials and supplies, services, travel, and up to the first \$25,000 of each subaward (regardless of the period of performance of the subawards under the award). MTDC excludes equipment, capital expenditures, charges for patient care, rental costs, tuition remission, scholarships and fellowships, participant support costs and the portion of each subaward in excess of \$25,000. Violation of cost accounting principles is not permitted when charging costs to awards. Rather, costs must be consistently charged as either indirect or direct costs. If the cognizant agency issues a negotiated rate subsequent to award, the negotiated rate may not be retroactively applied.

2. Subcontract Restriction

The applicant is expected to perform a substantive portion of the project and no more than 50 percent of FPP, FP, and FLSP as determined by budget expenditures, may be subawarded. NIFA will allow applicants to indicate in their proposal if they intend to subcontract more than 50% of the award. This deviation will require NIFA approval. Projects may divide their budget allocations between partners as it fits their work plan. (For additional knowledge or expertise that is not available within the applicant organization, funds for expert consultation may be included in the "All Other Direct Costs" section of the proposed budget.)

3. Multiple Submissions

The FINI grants program will only accept one application across the three project types per project team under this RFA.

4. Funding Period Limitation

The maximum potential funding period (including any awards transferred from another institution or organization) is limited to 4 years in duration. The funding period will commence on the effective date cited in the award instrument. Any such limitation also applies to subcontracts made under awards subject to a funding period limitation.

5. Prohibiting Government-Sponsored Recruitment Activities

Grant funds may not be used for television, radio, or billboard advertisements that are designed to promote SNAP benefits and enrollment. Grant funds may also not be used for recruitment activities that are designed to persuade an individual to apply for SNAP.

E. Other Submission Requirements

You should follow the submission requirements noted in Part IV, section 1.9 in the document entitled “NIFA Grants.gov Application Guide.”

For information about the **status of a submitted application**, see Part III., section 6. of the NIFA Grants.gov Application Guide.

PART V—APPLICATION REVIEW REQUIREMENTS

A. General

We evaluate each application in a two-part process. First, we screen each application to ensure that it meets the administrative requirements as set forth in this RFA. Second, a technical review panel will evaluate applications that meet the administrative requirements.

We select reviewers based upon their training and experience in relevant scientific, extension, or education fields, taking into account the following factors: (a) The level of relevant formal scientific, technical education, or extension experience of the individual, as well as the extent to which an individual is engaged in relevant research, education, or extension activities; (b) the need to include as reviewers experts from various areas of specialization within relevant scientific, education, or extension fields; (c) the need to include as reviewers other experts (e.g., producers, range or forest managers/operators, and consumers) who can assess relevance of the applications to targeted audiences and to program needs; (d) the need to include as reviewers experts from a variety of organizational types (e.g., colleges, universities, industry, state and federal agencies, and private profit and non-profit organizations) and geographic locations; (e) the need to maintain a balanced composition of reviewers with regard to minority and female representation and an equitable age distribution; and (f) the need to include reviewers who can judge the effective usefulness of each application to producers and the general public.

When each peer review panel has completed its deliberations, the responsible program staff of the FINI grants program will recommend that the project: (a) be approved for support from currently available funds or (b) be declined due to insufficient funds or unfavorable review.

FINI grants program reserves the right to negotiate with the PD/PI and/or with the submitting organization or institution regarding project revisions (e.g., reductions in the scope of work, funding level, period, or method of support) prior to recommending any project for funding.

B. Evaluation Criteria

We will use the evaluation criteria below to review applications submitted in response to this RFA:

We will use the following evaluation criteria for FPPs, FPs, and FLSPs, competing within each category/project type and not across categories, listed in descending order of importance, to review applications submitted in response to this RFA:

1. How well the proposed project advances the primary goal of the FINI grants program which is to test and evaluate projects to increase the purchase of fruits and vegetables (as defined in Subpart VIII (E) of this document) by low-income consumers participating in SNAP by providing incentives at the point of purchase, using effective and efficient benefit redemption technologies.

All FINI projects must (1) have the support of the State SNAP agency, responsible for the administration of SNAP; (2) aim to increase the purchase of fruits and vegetables by low-income consumers participating in SNAP by providing incentives at the point of purchase; (3) operate through authorized SNAP retailers, and in compliance with all relevant SNAP regulations and operating requirements; (4) agree to participate in the FINI comprehensive program evaluation; (5) ensure that the same terms and conditions apply to purchases made by individuals with SNAP benefits and with incentives provided under the FINI grants program as apply to purchases made by individuals who are not members of households receiving benefits as provided in 7 C.F.R. 278.2(b); and (6) include effective and efficient technologies for benefit redemption systems that may be replicated in other States and communities.

Note: Because the statutory language of the 2014 Farm Bill requires FINI grantees to provide incentives specifically to SNAP clients, the equal treatment provision of 7 CFR 278.2(b) does not apply to FINI grantees for the purpose of providing incentives under the FINI grants.

2. How well the project aligns with and advances FINI grants program priorities, which are to:

- Maximize the share of funds used for direct incentives to participants;
- Test innovative or promising strategies that would contribute to our understanding of how best to increase the purchase of fruits and vegetables by SNAP participants, to inform future efforts;
- Develop innovative or improved benefit redemption systems that could be replicated or scaled;
- Use direct-to-consumer sales marketing;
- Demonstrate a track record of designing and implementing successful nutrition incentive programs that connect low-income consumers and agricultural producers (for FPs and FLSPs only);
- Provide locally or regionally produced fruits and vegetables, especially those culturally appropriate for the target audience; and/or
- Operate in underserved communities, particularly Promise Zones and StrikeForce Communities.

Identified priorities are factors that will be given additional weight in the evaluation of proposals. In instances where proposals are found to be equally meritorious with the application purpose and priorities, based on peer review, selection for funding will be weighed in favor of applicants meeting the FINI grants program priorities.

3. The significance of the low-income food security issues that will be addressed by the proposed project, and an informative description of the community, its characteristics, assets, and needs;
4. The appropriateness of the goals, objectives, and outcomes of the project and how these goals will be achieved throughout the project period;

5. The relevance of the experience of the organizations that are involved in the proposed project, including the applicant entity, and the type and extent of support that other organizations will be providing, or the extent to which these organizations demonstrate the capacity to contribute to the overall grant program. The applicant organization demonstrates a history of, commitment to, and/or direct involvement in food security or nutrition incentive projects in low-income communities or in communities with low-income groups, as well as success in actively engaging low-income participants. Benefits of the program will accrue primarily to the low income population. The qualifications of staff involved with the proposed project and/or organizational leadership reflects the expertise necessary to carry out the proposed activities or similar types of activities. Experience in and connections with the community and a demonstrated dedication to serving low income residents will be considered as important as academic or professional credentials in this regard. Professional salaries are in balance with compensation given to low-income residents for their participation in the initiative;
6. The strength of the proposed project's plans and capacity to undertake a self-assessment, collect the minimum core data set (for FPs and FLSPs only) with accuracy and validity, cooperate with and participate in an independent evaluation, share project results in an "exemplary practices" format;
7. Evidence is provided to demonstrate that the project is likely to become self-sustaining, e.g., a market analysis or the outlines of a business plan. Projects should identify actual or potential funding sources for continuation of the project after federal funding has ended; and
8. The timeline and budget for accomplishing project goals, objectives, and outcomes is realistic and achievable.

C. Conflicts of Interest and Confidentiality

During the peer evaluation process, we take extreme care to prevent any actual or perceived conflicts of interest that may impact review or evaluation. See http://www.nifa.usda.gov/business/competitive_peer_review.html for further information about conflicts of interest and confidentiality as related to the peer review process.

D. Organizational Management Information

Specific management information relating to an applicant shall be submitted on a one time basis, with updates on an as needed basis. This requirement is part of the responsibility determination prior to the award of a grant identified under this RFA, if such information has not been provided previously under this or another NIFA program. We will provide you copies of forms recommended for use in fulfilling these requirements as part of the preaward process. Although an applicant may be eligible based on its status as one of these entities, there are factors that may exclude an applicant from receiving federal financial and nonfinancial assistance and benefits

under this program (e.g., debarment or suspension of an individual involved or a determination that an applicant is not responsible based on submitted organizational management information).

E. Application Disposition

An application may be withdrawn at any time before a final funding decision is made regarding the application. Each application that is not selected for funding, including those that are withdrawn, will be retained by FINI grants program for a period of three years.

PART VI—AWARD ADMINISTRATION

A. General

Within the limit of funds available for such purpose, the NIFA awarding official shall make grants to those responsible, eligible applicants whose applications are judged most meritorious under the procedures set forth in this RFA. The date specified by the NIFA awarding official as the effective date of the grant shall be no later than September 30 of the federal fiscal year in which the project is approved for support and funds are appropriated for such purpose, unless otherwise permitted by law. The project need not be initiated on the grant effective date, but as soon thereafter as practical so that project goals may be attained within the funded project period. All funds granted by NIFA under this RFA may be used only for the purpose for which they are granted in accordance with the approved application and budget, regulations, terms and conditions of the award, applicable federal cost principles, USDA assistance regulations, and NIFA General Awards Administration Provisions at 7 CFR part 3430, subparts A through E.

B. Award Notice

The award document will provide pertinent instructions and information including, at a minimum:

- (1) Legal name and address of performing organization or institution to which the director has issued an award under the terms of this request for applications;
- (2) Title of project;
- (3) Name(s) and institution(s) of PDs chosen to direct and control approved activities;
- (4) Identifying award number and the Federal Agency Identification Number assigned by NIFA;
- (5) Project period, specifying the amount of time NIFA intends to support the project without requiring recompetition for funds;
- (6) Total amount of financial assistance approved for the award;
- (7) Legal authority(ies) under which the award is issued;
- (8) Appropriate Catalog of Federal Domestic Assistance (CFDA) number;
- (9) Applicable award terms and conditions (see <http://www.nifa.usda.gov/business/awards/awardterms.html> to view NIFA award terms and conditions);
- (10) Approved budget plan for categorizing allocable project funds to accomplish the stated purpose of the award; and

(11) Other information or provisions deemed necessary by NIFA to carry out its respective awarding activities or to accomplish the purpose of a particular award.

C. Administrative and National Policy Requirements

Several federal statutes and regulations apply to grant applications considered for review and to project grants awarded under this program. These may include, but are not limited to, the ones listed on the NIFA web page - <http://nifa.usda.gov/federal-regulations>.

NIFA Federal Assistance Policy Guide—a compendium of basic NIFA policies and procedures that apply to all NIFA awards, unless there are statutory, regulatory, or award-specific requirements to the contrary is available at <http://nifa.usda.gov/policy-guide>.

D. Expected Program Outputs and Reporting Requirements

The output and reporting requirements are included in the award terms and conditions (see <http://www.nifa.usda.gov/business/awards/awardterms.html> for information about NIFA award terms). If there are any program or award-specific award terms, those, if any, will be identified in the award.

PART VII—AGENCY CONTACTS

Applicants and other interested parties are encouraged to contact:

Programmatic Contacts –

Dr. Jane Clary Loveless; National Program Leader, National Institute of Food and Agriculture, USDA; 1400 Independence Avenue, SW, Mail Stop 2225 Washington, DC 20250-2225; telephone: 202-720-3891; fax: 202-720-9366; e-mail: jclary@nifa.usda.gov.

Dr. Dionne Toombs; Director, Division of Nutrition, National Institute of Food and Agriculture, USDA; 1400 Independence Avenue, SW, Mail Stop 2225 Washington DC 20250-2225; telephone: 202-401-2138; fax: 202-401-4888; email: dtoombs@nifa.usda.gov.

Administrative/Business Contacts –

Susan Bowman; Awards Management Branch Chief; Office of Grants and Financial Management; National Institute of Food and Agriculture, USDA; 1400 Independence Avenue, SW, Mail Stop 2271; Washington, DC 20250-2271; telephone 202-401-4324; fax 202-401-6271; e-mail sbowman@nifa.usda.gov.

Aдриене Woodin; Awards Management Branch Chief; Office of Grants and Financial Management; National Institute of Food and Agriculture, USDA; 1400 Independence Avenue, SW, Mail Stop 2271; Washington, DC 20250-2271; telephone 202-401-4320; fax 202-401-6271; e-mail awoodin@nifa.usda.gov.

PART VIII—OTHER INFORMATION

A. Access to Review Information

We will send copies of reviews, not including the identity of reviewers, and a summary of the panel comments to the applicant PD after the review process has been completed.

B. Use of Funds; Changes

1. Delegation of Fiscal Responsibility

Unless the terms and conditions of the award state otherwise, awardees may not in whole or in part delegate or transfer to another person, institution, or organization the responsibility for use or expenditure of award funds.

2. Changes in Project Plans

a. The permissible changes by the awardee, PD(s), or other key project personnel in the approved project shall be limited to changes in methodology, techniques, or other similar aspects of the project to expedite achievement of the project's approved goals. If the awardee or the PD(s) is uncertain as to whether a change complies with this provision, the question must be referred to the Authorized Departmental Officer (ADO) for a final determination. The ADO is the signatory of the award document, not the program contact.

b. The awardee must request, and the ADO must approve in writing, all changes in approved goals or objectives prior to effecting such changes. In no event shall requests be approved for changes that are outside the scope of the original approved project.

c. The awardee must request, and the ADO must approve in writing, all changes in approved project leadership or the replacement or reassignment of other key project personnel, prior to effecting such changes.

d. The awardee must request, and the ADO must approve in writing, all transfers of actual performance of the substantive programmatic work in whole or in part and provisions for payment of funds, whether or not federal funds are involved, prior to instituting such transfers, unless prescribed otherwise in the terms and conditions of the award.

e. The project period may be extended without additional financial support, for such additional period(s) necessary to complete or fulfill the purposes of an approved project, but in no case shall the total project period exceed any applicable statutory limit or expiring appropriation limitation. The terms and conditions of award include information about no-cost extensions of the award and when ADO's prior approval is necessary.

f. Changes in Approved Budget: Unless stated otherwise in the terms and conditions of award, changes in an approved budget must be requested by the awardee and approved in writing by the

ADO prior to instituting such changes, if the revision will involve transfers or expenditures of amounts requiring prior approval as set forth in the applicable Federal cost principles, Departmental regulations, or award.

C. Confidential Aspects of Applications and Awards

When an application results in an award, it becomes a part of the record of NIFA transactions, available to the public upon specific request. Information that the Secretary determines to be of a confidential, privileged, or proprietary nature will be held in confidence to the extent permitted by law. Therefore, any information that the applicant wishes to have considered as confidential, privileged, or proprietary should be clearly marked within the application. The original copy of an application that does not result in an award will be retained by the Agency for a period of three years. Other copies will be destroyed. Such an application will be released only with the consent of the applicant or to the extent required by law. An application may be withdrawn at any time prior to the final action thereon.

D. Regulatory Information

For the reasons set forth in the final Rule related Notice to 2 CFR part 415, subpart C , this program is excluded from the scope of the Executive Order 12372 which requires intergovernmental consultation with State and local officials. Under the provisions of the Paperwork Reduction Act of 1995 (44 U.S.C. chapter 35), the collection of information requirements contained in this Notice have been approved under OMB Document No. 0524-0039.

E. Definitions

Please refer to [7 CFR 3430, Competitive and Noncompetitive Non-formula Financial Assistance Programs--General Award Administrative Provisions](#), for applicable definitions for this NIFA grant program.

For the purpose of this program, the following additional definitions are applicable:

Community Food Assessment is a collaborative and participatory process that systematically examines a broad range of community food issues and assets, so as to inform change actions to make the community more food secure.

Emergency Feeding Organization means a public or nonprofit organization that administers activities and projects (including the activities and projects of a charitable institution, a food bank, a food pantry, a hunger relief center, a soup kitchen, or a similar public or private nonprofit eligible recipient agency) providing nutrition assistance to relieve situations of emergency and distress through the provision of food to needy persons, including low-income and unemployed persons. (See 7 U.S.C. 7501).

Exemplary practices means high quality community food security work that emphasizes food security, nutritional quality, environmental stewardship, and economic and social equity.

Expert reviewers means individuals selected from among those recognized as uniquely qualified by training and experience in their respective fields to give expert advice on the merit of grant applications in such fields who evaluate eligible proposals submitted to this program in their respective area(s) of expertise.

Food security means access to affordable, nutritious, and culturally appropriate food for all people at all times.

Fruits and Vegetables means for the purposes of the incentives provided under these grants (i.e. as used in Section 4208) any variety of fresh, canned, dried, or frozen whole or cut fruits and vegetables without added sugars, fats, or oils, and salt (i.e. sodium).

Incentives are defined as any financial or non-financial inducements that would increase the purchase and consumption of eligible fruits and vegetables by SNAP clients. See page 6 for details.

Logic model means a systematic and visual way to present and share an understanding of the relationships among resources available to operate a program, and includes: planned activities and anticipated results; and the presentation of the resources, inputs, activities, outputs, outcomes and impacts.

Outcomes means the changes in the wellbeing of individuals that can be attributed to a particular project, program, or policy, or that a program hopes to achieve over time. They indicate a measurable change in participant knowledge, attitudes, or behaviors. For the purposes of this document, ‘impact’ and ‘outcome’ are used interchangeably.

Process evaluation means examining program activities in terms of (1) the age, sex, race, occupation, or other demographic variables of the target population; (2) the program’s organization, funding, and staffing; and (3) its location and timing. Process evaluation focuses on program activities rather than outcomes.

PromiseZone refers to designated high-poverty communities “where the federal government will partner with and invest in communities to create jobs, leverage private investment, increase economic activity, expand educational opportunities, and improve public safety.” See <https://www.hudexchange.info/programs/promise-zones/> for more information.

Non-profit Organization means a Nonprofit corporation is a special type of corporation that has been organized to meet specific tax-exempt purposes. To qualify for Nonprofit status, your corporation must be formed to benefit: (1) the public, (2) a specific group of individuals, or (3) the membership of the Nonprofit.

StrikeForce means the “USDA’s StrikeForce for Rural Growth and Opportunity Initiative which works to address the unique set of challenges faced by many of America’s rural communities. Through StrikeForce, USDA is leveraging resources and collaborating with partners and stakeholders to improve economic opportunity and quality of life in these areas.” See http://www.usda.gov/wps/portal/usda/usdahome?navid=STRIKE_FORCE for more information.

Supplemental Nutrition Assistance Program (SNAP) means the supplemental nutrition assistance program established under the Food and Nutrition Act of 2008 (7 U.S.C. 2011 *et seq*).

Value Chain means adding value to a product, including production, marketing, and the provision of after-sales service and incorporating fair pricing to farms. It also involves keeping the final pricing to customers within competitive range. Value chain development, therefore, is a process of building relationships between supplier and buyer that are reciprocal and win-win; instead of always striving to buy at lowest cost.

F. Materials Available on the Internet

FINI grants program information will be made available on the NIFA web site at <http://nifa.usda.gov/program/food-insecurity-nutrition-incentive-fini-grant-program>

The following are among the materials available on the web page:

1. General Information
2. Resources, including webinars and FAQs
3. Program Specific Resources

*This Page
Intentionally
Left Blank*



AGENDA REPORT

To: Mayor Joel Fajardo and Councilmembers

From: Brian Saeki, City Manager

Date: December 7, 2105

Subject: Discussion of Pioneer Park - Play Equipment Upgrades and Fencing

RECOMMENDATION:

That the City Council provide staff with direction regarding and improvements at Pioneer Park.

BACKGROUND:

Councilmember Soto has requested that the City Council discuss play equipment upgrades and fencing at Pioneer Park.

BUDGET IMPACT:

Unknown at this time.

*This Page
Intentionally
Left Blank*

*This Page
Intentionally
Left Blank*



AGENDA REPORT

To: Mayor Joel Fajardo and Councilmembers

From: Brian Saeki, City Manager

Date: December 7, 2105

Subject: Discussion of an Appeal of the Planning and Preservation Commission's Action on October 6, 2015 Related to the Transit Oriented Development Overlay Project

RECOMMENDATION:

That the City Council provide staff with direction regarding any action related to an appeal of the Planning and Preservation Commission's action on October 6, 2015.

BACKGROUND:

Councilmember Soto has requested that the City Council discuss the attached response from the City regarding an appeal of the Planning and Preservation Commission's action on October 6, 2015.

BUDGET IMPACT:

Unknown at this time.

ATTACHMENT:

A. Response Letter to Appellants

THE CITY OF SAN FERNANDO

CITY COUNCIL

November 25, 2015

MAYOR
JOEL FAJARDO

Mary Mendoza, Appellant
632 South Brand Blvd
San Fernando, CA 91340

VICE MAYOR
SYLVIA BALLIN

COUNCILMEMBER
ANTONIO LOPEZ

SUBJECT: Response to Letter to City Council from Mary Mendoza and Others
Regarding Planning and Preservation Commission Resolution No. 2015-06

COUNCILMEMBER
ROBERT C. GONZALES

Dear Mss. A. Balderas, L. Camacho, A. Lopez, C. Lopez, and M. Mendoza:

COUNCILMEMBER
JAIME SOTO

Attached is the memorandum from the City Attorney's Office in response to your query concerning whether the approval of the Planning and Preservation Commission Resolution No. 2015-06 is a proper subject for appeal as requested in your correspondence received by the City of San Fernando on or about October 15, 2015 letter attached herein. As noted in the attached memorandum, it is the City's assessment that the Planning and Preservation Commission Resolution 2015-06 is not a proper subject for appeal.

Nevertheless you are encouraged to attend subsequent meetings of the Planning and Preservation Commission (regular meetings are typically held the first Tuesday of every month) and the City Council (typically held the first and third Mondays of every month) and voice any further testimony and comments that you deem warranted. In addition, you are invited to attend future publicly noticed meetings before the Planning and Preservation Commission and the City Council on the TOD Overlay Project/Specific Plan Amendment and associated Environmental Impact Report that will begin to be scheduled in early 2016.

Sincerely,

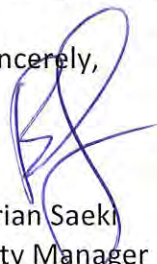

Brian Saeki
City Manager

cc: City Council
Rick Olivarez, City Attorney
Fred Ramirez, Community Development Director

ADMINISTRATION
DEPARTMENT

117 MACNEIL STREET
SAN FERNANDO
CALIFORNIA
91340

Attachments/

(818) 898-1202

WWW.SFCITY.ORG

THE CITY OF SAN FERNANDO

CITY COUNCIL

November 25, 2015

MAYOR
JOEL FAJARDO

Anna Lopez, Appellant
1011 Fifth Street

VICE MAYOR
SYLVIA BALLIN

San Fernando, CA 91340

COUNCILMEMBER
ANTONIO LOPEZ

SUBJECT: Response to Letter to City Council from Mary Mendoza and Others
Regarding Planning and Preservation Commission Resolution No. 2015-06

COUNCILMEMBER
ROBERT C. GONZALES

Dear Mss. A. Balderas, L. Camacho, A. Lopez, C. Lopez, and M. Mendoza:

COUNCILMEMBER
JAIME SOTO

Attached is the memorandum from the City Attorney's Office in response to your query concerning whether the approval of the Planning and Preservation Commission Resolution No. 2015-06 is a proper subject for appeal as requested in your correspondence received by the City of San Fernando on or about October 15, 2015 letter attached herein. As noted in the attached memorandum, it is the City's assessment that the Planning and Preservation Commission Resolution 2015-06 is not a proper subject for appeal.

Nevertheless you are encouraged to attend subsequent meetings of the Planning and Preservation Commission (regular meetings are typically held the first Tuesday of every month) and the City Council (typically held the first and third Mondays of every month) and voice any further testimony and comments that you deem warranted. In addition, you are invited to attend future publicly noticed meetings before the Planning and Preservation Commission and the City Council on the TOD Overlay Project/Specific Plan Amendment and associated Environmental Impact Report that will begin to be scheduled in early 2016.

Sincerely,

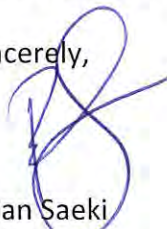

Brian Saeki
City Manager

cc: City Council
Rick Olivarez, City Attorney
Fred Ramirez, Community Development Director

ADMINISTRATION
DEPARTMENT

117 MACNEIL STREET
SAN FERNANDO
CALIFORNIA
91340

Attachments/

(818) 898-1202

WWW.SFCITY.ORG

THE CITY OF SAN FERNANDO

CITY COUNCIL

November 25, 2015

MAYOR
JOEL FAJARDO

Cyndi Lopez, Appellant
2019 Lucas Street

VICE MAYOR
SYLVIA BALLIN

San Fernando, CA 91340

COUNCILMEMBER
ANTONIO LOPEZ

SUBJECT: Response to Letter to City Council from Mary Mendoza and Others
Regarding Planning and Preservation Commission Resolution No. 2015-06

COUNCILMEMBER
ROBERT C. GONZALES

Dear Mss. A. Balderas, L. Camacho, A. Lopez, C. Lopez, and M. Mendoza:

COUNCILMEMBER
JAIME SOTO

Attached is the memorandum from the City Attorney's Office in response to your query concerning whether the approval of the Planning and Preservation Commission Resolution No. 2015-06 is a proper subject for appeal as requested in your correspondence received by the City of San Fernando on or about October 15, 2015 letter attached herein. As noted in the attached memorandum, it is the City's assessment that the Planning and Preservation Commission Resolution 2015-06 is not a proper subject for appeal.

Nevertheless you are encouraged to attend subsequent meetings of the Planning and Preservation Commission (regular meetings are typically held the first Tuesday of every month) and the City Council (typically held the first and third Mondays of every month) and voice any further testimony and comments that you deem warranted. In addition, you are invited to attend future publicly noticed meetings before the Planning and Preservation Commission and the City Council on the TOD Overlay Project/Specific Plan Amendment and associated Environmental Impact Report that will begin to be scheduled in early 2016.

Sincerely,



Brian Saeki
City Manager

cc: City Council
Rick Olivarez, City Attorney
Fred Ramirez, Community Development Director

ADMINISTRATION
DEPARTMENT

117 MACNEIL STREET
SAN FERNANDO
CALIFORNIA
91340

Attachments/

(818) 898-1202

WWW.SFCITY.ORG

THE CITY OF SAN FERNANDO

CITY COUNCIL

November 25, 2015

MAYOR
JOEL FAJARDO

Lupita Camacho, Appellant
311 South Maclay
San Fernando, CA 91340

VICE MAYOR
SYLVIA BALLIN

COUNCILMEMBER
ANTONIO LOPEZ

SUBJECT: Response to Letter to City Council from Mary Mendoza and Others
Regarding Planning and Preservation Commission Resolution No. 2015-06

COUNCILMEMBER
ROBERT C. GONZALES

Dear Mss. A. Balderas, L. Camacho, A. Lopez, C. Lopez, and M. Mendoza:

COUNCILMEMBER
JAIME SOTO

Attached is the memorandum from the City Attorney's Office in response to your query concerning whether the approval of the Planning and Preservation Commission Resolution No. 2015-06 is a proper subject for appeal as requested in your correspondence received by the City of San Fernando on or about October 15, 2015 letter attached herein. As noted in the attached memorandum, it is the City's assessment that the Planning and Preservation Commission Resolution 2015-06 is not a proper subject for appeal.

Nevertheless you are encouraged to attend subsequent meetings of the Planning and Preservation Commission (regular meetings are typically held the first Tuesday of every month) and the City Council (typically held the first and third Mondays of every month) and voice any further testimony and comments that you deem warranted. In addition, you are invited to attend future publicly noticed meetings before the Planning and Preservation Commission and the City Council on the TOD Overlay Project/Specific Plan Amendment and associated Environmental Impact Report that will begin to be scheduled in early 2016.

Sincerely,



Brian Saeki
City Manager

cc: City Council
Rick Olivarez, City Attorney
Fred Ramirez, Community Development Director

ADMINISTRATION
DEPARTMENT

117 MACNEIL STREET
SAN FERNANDO
CALIFORNIA
91340

Attachments/

(818) 898-1202

WWW.SFCITY.ORG

THE CITY OF SAN FERNANDO

CITY COUNCIL

November 25, 2015

MAYOR
JOEL FAJARDO

Anatolia Balderas, Appellant
1011 Fifth Street
San Fernando, CA 91340

VICE MAYOR
SYLVIA BALLIN

COUNCILMEMBER
ANTONIO LOPEZ

SUBJECT: Response to Letter to City Council from Mary Mendoza and Others Regarding Planning and Preservation Commission Resolution No. 2015-06

COUNCILMEMBER
ROBERT C. GONZALES

Dear Mss. A. Balderas, L. Camacho, A. Lopez, C. Lopez, and M. Mendoza:

COUNCILMEMBER
JAIME SOTO

Attached is the memorandum from the City Attorney's Office in response to your query concerning whether the approval of the Planning and Preservation Commission Resolution No. 2015-06 is a proper subject for appeal as requested in your correspondence received by the City of San Fernando on or about October 15, 2015 letter attached herein. As noted in the attached memorandum, it is the City's assessment that the Planning and Preservation Commission Resolution 2015-06 is not a proper subject for appeal.

Nevertheless you are encouraged to attend subsequent meetings of the Planning and Preservation Commission (regular meetings are typically held the first Tuesday of every month) and the City Council (typically held the first and third Mondays of every month) and voice any further testimony and comments that you deem warranted. In addition, you are invited to attend future publicly noticed meetings before the Planning and Preservation Commission and the City Council on the TOD Overlay Project/Specific Plan Amendment and associated Environmental Impact Report that will begin to be scheduled in early 2016.

Sincerely,

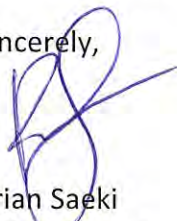

Brian Saeki
City Manager

cc: City Council
Rick Olivarez, City Attorney
Fred Ramirez, Community Development Director

ADMINISTRATION
DEPARTMENT

117 MACNEIL STREET
SAN FERNANDO
CALIFORNIA
91340

Attachments/

(818) 898-1202

WWW.SFCITY.ORG

MEMORANDUM

Date: November 25, 2015

To: Brian Saeki, City Manager
Fred Ramirez, Community Development Director

From: Office of the City Attorney *JRP Ricardo Padilla*

Subject: Response to Letter to City Council from Mary Mendoza and Others
Regarding Planning and Preservation Commission Resolution No.
2015-06

This memorandum is in response to your query concerning whether the approval of Planning and Preservation Commission Resolution No. 2015-06 is a proper subject for appeal as requested in correspondence received by the City of San Fernando ("City") on or about October 15, 2015 (hereinafter, the "Letter"). (A true and correct copy of the October 15, 2015 letter is attached hereto as **Exhibit "A"**). Resolution No. 2015-06 relates to the proposed Update to the San Fernando Corridors Specific Plan and transit oriented development.

1. SHORT ANSWER

To the extent the Letter is intended as an "appeal" of a formal decision of the Planning and Preservation Commission ("Commission"), Resolution No. 2015-06 is not subject to appeal, for the reasons described below.

2. ANALYSIS

The Letter refers to "the decision to allow for more apartments..." (p. 1), and asks the Council "to reconsider the Final Decision" of the Commission (p. 2), among other things. In consultation with City Planning Staff ("Staff") and based on their representations, it appears that, in contrast to a "decision," the Resolution merely gives direction and feedback requested by Staff. A Commission decision on this project will come later.

November 25, 2015

Page 2

To function, the Commission must direct Staff, and such directives lead to work product (in this case a proposed Specific Plan Update and draft EIR) that will subsequently be brought to the Commission for consideration and action. A directive is unlike an appealable determination, interpretation, decision, or judgment because it is merely an interim and necessary step to advance the work of the Commission. A directive, on its own, is of no real consequence unless it results in a product that the Commission can consider and vote on.

With respect to this project, it is our understanding that Commission meetings have not yet resulted in an appealable action. Nevertheless, it is our understanding that a series of scoping meetings and public hearings will be scheduled wherein the Letter's authors may submit written testimony regarding the proposed undertaking which may include any and all objections and concerns they have along with supporting evidence and testimony. For example, it is our understanding that the City will conduct a public scoping meeting to invite community input on the project and the environmental analysis. The public may submit comments on the draft EIR, and the Commission will eventually vote on its recommendation to the City Council. The City Council, in turn will then take up the issue, affording the Letter's authors yet another opportunity to provide comment and testimony before any sort of final action is taken.

3. CONCLUSION

Accordingly, Resolution No. 2015-06 is not a proper subject for appeal. Nevertheless, the Letter's authors should be given information about dates and times for upcoming public meetings on this matter and should be encouraged to submit any written testimony and comments they deem warranted.

EXHIBIT A

October 15, 2015

San Fernando City Council
117 Macneil
San Fernando, CA 91340

Mayor Joel Fajardo and City Councilmembers,

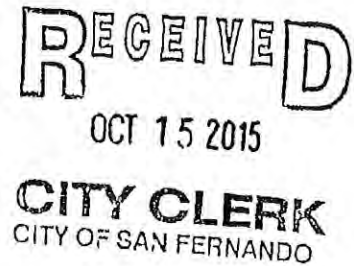

We, residents of the City of San Fernando, submit to the San Fernando City Council a formal appeal of the City Planning and Preservation Commission's 3-2 split decision at the Tuesday, October 6, 2015 Public Hearing in regards to the Transit Oriented Development (TOD) Overlay Project and Proposed Update to the San Fernando Corridors Specific Plan (Specific Plan). We ask that the decision to allow for more apartments or multi-family units be immediately repealed and the Specific Plan be amended to reflect the desires of the residents of San Fernando before proceeding with any preparation of an associated Environmental Impact Report (EIR).

The 3-2 split decision made on the following City Planning and Preservation Public Hearing agenda item is being appealed:

SUBJECT: TRANSIT ORIENTED DEVELOPMENT (TOD) OVERLAY PROJECT AND PROPOSED UPDATE TO THE SAN FERNANDO CORRIDORS SPECIFIC PLAN

LOCATION: CITYWIDE

APPLICANT: CITY OF SAN FERNANDO, COMMUNITY DEVELOPMENT, 117 MACNEIL STREET, SAN FERNANDO, CA 91340

RECOMMENDATION: IT IS RECOMMENDED THAT SUBSEQUENT TO CITY CONSULTANT SARGENT TOWN PLANNING'S PRESENTATION AND CONSIDERATION OF ANY PUBLIC COMMENTS, THE PLANNING AND PRESERVATION COMMISSION:

- 1. PROVIDE CITY STAFF AND THE CITY CONSULTANT WITH FEEDBACK ON THE PROPOSED CHANGES TO THE LAND USES, DEVELOPMENT STANDARDS AND DESIGN GUIDELINES BEING CONSIDERED AS PART OF THE PROPOSED UPDATE OF THE SAN FERNANDO CORRIDORS SPECIFIC PLAN (ATTACHMENT1); AND,*
- 2. ADOPT PLANNING AND PRESERVATION COMMISSION RESOLUTION NO. 2015-06, AUTHORIZING CITY PLANNING STAFF AND THE CITY CONSULTANT TO FINALIZE THE PROPOSED CHANGES TO DRAFT VERSION OF THE SAN FERNANDO CORRIDORS SPECIFIC PLAN UPDATE BEFORE PROCEEDING WITH THE PREPARATION OF THE ASSOCIATED ENVIRONMENTAL IMPACT REPORT (EIR).*

We respect the work of the City Planning and Preservation Commission members and the City staff; however we strongly feel that the majority of the City Planning and Preservation and the City staff did

not give the community's comments, input and suggestions the proper respect, understanding and due diligence that is deserving of our community.

We are asking the City Council to reconsider the Final Decision made by the Planning and Preservation Commission at the Tuesday, October 6, 2015 Public Hearing, including but not limited to the following reasons:

The Community's Strong Opposition to More Apartments and Multi-Family Units Was Ignored

The San Fernando City Council Chamber was filled to capacity with several community members standing in the back entrance and outside.

All but one of at least 25 speakers spoke in strong opposition to more apartments and multi-family units. In addition, 60 letters, 3 emails and over 350 signatures on a petition in opposition to more multi-family residential units were presented or submitted to the Planning and Preservation Commission.

Arguments in opposition were made from community members who ranged from 80 year residents to 3 year residents and reflected the diversity of the people of San Fernando. The community was united against more multi-family residential units.

The community made it crystal clear that the final proposed changes adopted by the City Planning and Preservation Commission to the draft version of the San Fernando Corridors Specific Plan Update before proceeding with the preparation of the associated environmental impact report (EIR) should at minimum remove apartments from the Downtown, preserve San Fernando's historic character, decrease building height limits and lower density in all sections of the proposed amended Corridors Specific Plan.

No Legal Requirement Exists for the City of San Fernando to Increase Housing Density as the City of San Fernando has Satisfied the Goals of the 2014-2021 Housing Element Plan

The City Planning and Preservation Commission provided no reasons for increasing the number of multi-family units beyond what is outlined in the 2014-2021 Housing Element Plan despite valid concerns raised by residents on the inability of the city's aging infrastructure to handle more residential density.

City Staff had been arguing that the City of San Fernando could potentially be in violation of State laws relative to the 2014-2021 Housing Element Plan and face decertification of its Housing Element Plan if more apartments were not approved through the proposed amended Corridors Specific Plan. The city staff's responses to questions raised by the Planning and Preservation Commission chair and members of the community on whether or not the City of San Fernando would be in compliance with the Housing Element Plan were in direct contradiction to information that had been provided to the community in previous meetings.

The City of San Fernando has met its goals and obligations under the 2014-2021 Housing Element Plan, so no legal requirements exist for the City to increase housing density.

Due Process: The City Attorney Was Not Present at the Public Hearing to Advise the Planning and Preservation Commission on Basic Procedures, Brown Act, Meeting Rules of Order and other Procedures

The City Attorney was not present during a significant, complex and controversial public hearing regarding the proposed amendment to the San Fernando Corridors Specific Plan. Although City Manager Brian Saeki was present at the Public Hearing, he did not provide objective procedural guidance to the City Planning and Preservation commissioners as is provided when the City Attorney is present.

No City Attorney or City Staff were present to provide unbiased and direct advice on procedural motions to the Planning and Preservation commissioners. It was clear at the October 6, 2015 meeting that Commissioners Kevin Belieu and David Bernal intended to ask the Planning and Preservation Commission to vote on a motion to at minimum remove apartments from the Downtown. Commissioner Yvonne Mejia stated on the record that she would be open to removing apartments from the Downtown; however the City staff did not provide fair and unbiased guidance on how that motion could be made and voted on even though at least three commissioners expressed support for amending out the possibility of more multi-family residential units in the Downtown. It is important to note, that Commissioner David Bernal had just been sworn in as commissioner at the start of the Tuesday, October 6, 2015 Planning and Preservation Commission meeting, so it would have been appropriate for the City Attorney to provide unbiased advice on procedural motions and the meeting's Rules of Order.

Instead Mr. Fred Ramirez, Community Development Director and Mr. Dave Sargent, Metro T.O.D. Consultant advised the Planning and Preservation Commissioners to devise a motion that supported the staff's desire to include the staff's proposed changes to the draft version of the San Fernando Corridors Specific Plan Update allowing for at least 759 multi-family residential units before proceeding with the preparation of the associated environmental impact report (EIR). That recommendation was contrary to the expressed intent of the commissioners and the community's desire to not allow more multi-family units.

Furthermore, Chair Theale Haupt stated on the record that he would recommend that all multi-family units along 2nd Street be limited to one floor to provide a better transition to the surrounding neighborhood. The staff never advised that a motion was necessary for that amendment to be made.

Commissioner Yvonne Mejia stated she would support a historic downtown; however her recommendation also failed to go anywhere as staff failed to provide advice on how to move amendments forward.

These are only a few examples of how the Planning and Preservation Commission was provided biased guidance on how to amend the staff's proposed changes to the Specific Plan. It was clear that the Commissioners were intentionally provided advice on how to make motions that were biased towards the City staff's and the T.O.D. consultant's desires to move their recommendations forward allowing for at least 759 multi-family units as presented to the Planning and Preservation commission without any amendments and removal of more apartments in the Downtown as requested and intended by at least three Planning and Preservation commissioners and by the community.

Insufficient Review Period of Proposed Redlined Corridors Specific Plan

There was not sufficient time for public review. City Planning and Preservation Commissioners and community members requested additional time to review a large amount of information (421 pages of information) that was posted online on September 30, 2015. Commissioner Kevin Belieu specifically made a motion that was seconded by Commissioner Dave Bernal to postpone the decision for two weeks until Tuesday, October 20, 2015 to provide for a longer review period. When the question was called Commissioner Yvonne Mejia stated that she would not be available to attend a meeting on Tuesday, October 20, 2015. An objective City staff or City Attorney should have provided the factual information to Commissioner Kevin Belieu that he could make a friendly amendment to his motion to set a date for when Commission Yvonne Mejia could be present. **No objective, independent and unbiased procedural information was provided to the Planning and Preservation commissioners contrary to the verbally expressed intent by at least three commissioners who were open to postponing the decision to allow for a longer public review period.**

We also have concerns given the limited discussion on various issues and the fact that no commissioner ever referred to specific pages in the redlined proposed amended Specific Plan or public comments contained in the agenda packet whether or not all commissioners had read the entire package. We expect each City Councilmember and Commissioner to thoroughly read and comprehend the details of what they are voting on.

Failure to Comply by the Public Hearing Notice and Agenda Items

The City Staff and City Consultant failed to comply with the Public Hearing Agenda to receive *"feedback on the proposed changes to the land uses, development standards and design guidelines being considered as part of the proposed update of the San Fernando Corridors Specific Plan."*

At least 25 people spoke in opposition to more apartments and raised concerns with the fact that the City of San Fernando has already satisfied the 2014-2021 Housing Element Plan, existing sewer issues, water supply, planning around unfunded Metro projects, increased density, loss of valuable commercial and industrial land uses, destruction of the historic character of San Fernando among other environmental and economic

cumulative impacts; however no robust discussion took place around any of those additional serious issues. And as previously noted, no amendments were made to the staff's presentation.

The City Planning and Preservation Commission failed to listen to comments, feedback, recommended amendments and other suggestions provided by hundreds of community members. No responses were provided nor feedback accepted by the City Planning and Preservation Committee, the City staff nor the Consultant on several questions, concerns and proposed changes raised by the community.

In addition, the Public Hearing Notice did not outline the possibility for two Environmental Impact Reports (EIR).

"ADOPT PLANNING AND PRESERVATION COMMISSION RESOLUTION NO. 2015-06, AUTHORIZING CITY PLANNING STAFF AND THE CITY CONSULTANT TO FINALIZE THE PROPOSED CHANGES TO DRAFT VERSION OF THE SAN FERNANDO CORRIDORS SPECIFIC PLAN UPDATE BEFORE PROCEEDING WITH THE PREPARATION OF THE ASSOCIATED ENVIRONMENTAL IMPACT REPORT (EIR)."

Two Environmental Impact Reports (EIR) were approved. An EIR must be prepared when there is substantial evidence that a project will have a significant effect on the environment. There was no item on the Agenda stating that two EIR's would be approved. The public was not given notice of this item prior to giving their testimony on the Agenda items. An EIR is an important issue and can be costly to the city. The subject matter of the additional EIR was a deviation of subject matter from the items listed on the Agenda.

As per § 54954.2. of the Brown Act, No action or discussion shall be undertaken on items not appearing on agenda. There is a clear violation of this section. No Agenda item stated that an additional EIR would be approved. It is a requirement that substantial evidence must exist for an EIR to be prepared. Such evidence would be a deviation from the items noticed on the Agenda. In addition, the discussion of such evidence was not listed as an item on the agenda.

As per § 54954.3. of the Brown Act, the public has a right to testify. There must be an opportunity to directly address the legislative body on any item of interest to the public. The public was not notified that an additional EIR would be approved, the circumstances in which an additional EIR would be approved, or that there existed substantial evidence demonstrating that an additional EIR needed to be approved. The public was not allowed to testify to the validity of such facts, the cost to the city or any other issue that applies to an additional EIR.

City Staff and the Consultants advised the City Planning and Preservation Commission to finalize the staff's proposed changes to the Specific Plan **despite at least three**

commissioners expressing a desire to support the community's request to remove multi-family residential units from the Downtown and proceed with the one associated EIR. There was never any notice given to the public that the staff report would be or had to be adopted as presented and that an additional option would be evaluated under the associated Environmental Impact Report.

We ask that the decision to allow for more apartments be immediately repealed and the Specific Plan be amended to reflect the desires of the residents of San Fernando before proceeding with any preparation of an associated Environmental Impact Report (EIR).

The community was very clear in its vision and desires for our small town. We ask that the City Council remove any apartments or multi-family units in the amended Corridors Specific Plan outside of the R-3 zone. We also ask that the City Council significantly rewrite the proposed amended Corridors Specific Plan to reflect the community's desire to protect the small-town, historic nature of San Fernando, focus on attracting middle-class jobs, better retail, restaurants and cafes and increase open space.

We are concerned about the City's aging infrastructure, water quality and supply, overburdened city services, and other significant environmental and economic cumulative impacts, and expect each one of the City Council members to make decisions that reflect the desires of the people who live in San Fernando not an outside agency like the Metropolitan Transit Authority.

Therefore, we are appealing to you as our elected body to repeal and amend the City Planning and Preservation Commission's 3-2 split decision to retain the option of multi-family residential units in the proposed amended Corridors Specific Plan and their failure make other amendments to land uses, development standards and design guidelines being considered as part of the proposed update of the San Fernando Corridors Specific Plan.

We ask that you listen to the October 6, 2015 City Planning and Preservation Committee Public Hearing recorded tape and read all letters and emails submitted for the record. We would also like to request a meeting with each of you to discuss this appeal and other amendments that should be made prior to the start of a full Environmental Impact Report.

Sincerely,



Mary Mendoza, Appellant
632 South Brand Blvd.
San Fernando, CA 91340

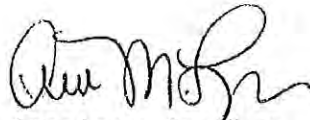

Anna Lopez, Appellant
1011 Fifth Street
San Fernando, CA 91340



Cyndi Lopez, Appellant
2019 Lucas Street
San Fernando, CA 91340

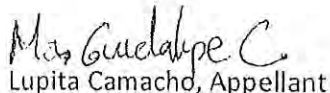

Lupita Camacho, Appellant
311 South Maclay
San Fernando, CA 91340

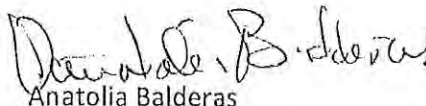

Anatolia Balderas
1011 Fifth Street
San Fernando, CA 91340