



SAN FERNANDO CITY COUNCIL
REGULAR MEETING NOTICE AND AGENDA
TUESDAY, FEBRUARY 16, 2016 – 6:00 PM

COUNCIL CHAMBERS
117 MACNEIL STREET
SAN FERNANDO, CA 91340

CALL TO ORDER/ROLL CALL

Mayor Joel Fajardo
Vice Mayor Sylvia Ballin
Councilmember Robert C. Gonzales
Councilmember Antonio Lopez
Councilmember Jaime Soto

PLEDGE OF ALLEGIANCE

San Fernando Police Explorer Michael Hernandez

APPROVAL OF AGENDA

PUBLIC STATEMENTS – WRITTEN/ORAL

There will be a three (3) minute limitation per each member of the audience who wishes to make comments relating to City Business. Anyone wishing to speak, please fill out the blue form located at the Council Chambers entrance and submit it to the City Clerk. When addressing the City Council please speak into the microphone and voluntarily state your name and address.

CONSENT CALENDAR

Items on the Consent Calendar are considered routine and may be disposed of by a single motion to adopt staff recommendation. If the City Council wishes to discuss any item, it should first be removed from the Consent Calendar.

SAN FERNANDO CITY COUNCIL**Regular Meeting Notice and Agenda – February 16, 2016**Page 2 of 4

- 1) REQUEST TO APPROVE MINUTES OF FEBRUARY 1, 2016 – REGULAR MEETING**
- 2) CONSIDERATION TO ADOPT RESOLUTION NO. 16-022 APPROVING THE WARRANT REGISTER**
- 3) CONSIDERATION TO INSTALL STREET STRIPING AND MARKING IMPROVEMENTS ON ARROYO AVENUE ADJACENT TO CESAR CHAVEZ LEARNING ACADEMY**

Recommend that the City Council:

- a. Approve the Transportation and Safety Commission's recommendation to install traffic and safety striping improvements on Arroyo Avenue, adjacent to Cesar Chavez Learning Academy; and
- b. Approve the striping plans and specifications.

- 4) CONSIDERATION TO ADOPT AN ORDINANCE AMENDING DIVISION 5 (TEMPORARY USES AND STRUCTURES) OF CHAPTER 106 (ZONING) OF THE CITY CODE IN ORDER TO ESTABLISH REGULATIONS FOR UNATTENDED COLLECTION BOXES**

Recommend that the City Council waive further reading of Ordinance No. 1651 and adopt by title only, "An Ordinance of the City Council of the City of San Fernando, California, Amending Division 5 (Temporary Uses and Structures) of Chapter 106 (Zoning) of the San Fernando City Code to Regulate Unattended Collection Boxes."

- 5) CONSIDERATION TO AUTHORIZE SUBMITTAL OF AN APPLICATION TO THE CALIFORNIA DEPARTMENT OF HOUSING AND COMMUNITY DEVELOPMENT HOUSING RELATED PARKS PROGRAM GRANT TO FUND LAYNE PARK IMPROVEMENTS**

Recommend that the City Council:

- a. Adopt Resolution No. 7725 authorizing the City's submittal of a grant application to the California Department of Housing and Community Development Housing Related Parks Program in the amount of \$193,950 to provide funds for park improvements at Layne Park;
- b. Authorize the City Manager to accept the grant, if awarded;
- c. Authorize the City Manager to execute all related grant documents required for receiving such grant funds pursuant to the terms and conditions of the grant; and

SAN FERNANDO CITY COUNCIL**Regular Meeting Notice and Agenda – February 16, 2016**Page 3 of 4

- d. Upon full execution of all grant related documents, authorize the appropriate revenue and expenditure budget amendments as outlined in the Fiscal Impact section of this report.

ADMINISTRATIVE REPORTS**6) UPDATE ON COUNTYWIDE PARK NEEDS ASSESSMENT**

Recommend that the City Council provide staff direction on the final recreation facility projects prior to submission to Los Angeles County Department of Parks and Recreation.

7) PRESENTATION OF FISCAL YEAR 2014-2015 COMPREHENSIVE ANNUAL FINANCIAL REPORT

Recommend that the City Council receive and file a presentation of the Fiscal Year 2014-2015 Comprehensive Annual Financial Report.

8) PRESENTATION OF FISCAL YEAR 2015-2016 MID-YEAR BUDGET REVIEW AND FISCAL YEAR (FY) 2016-2017 BUDGET OUTLOOK

Recommend that the City Council:

- a. Review and discuss the FY 2015-2016 Mid-Year Budget Review and FY 2016-2017 Budget Outlook; and
- b. Adopt Resolution No. 7726, amending the City's FY 2015-2016 budget to include the proposed changes.

9) CONSIDERATION TO ASSESS THE POTENTIAL ENFORCEMENT OF EMISSIONS OF ICE CREAM TRUCKS AND RELATED VENDORS

This item is placed on the agenda by Councilmember Jaime Soto.

10) CONSIDERATION TO ASSESS THE FEASIBILITY OF AMENDING THE SAN FERNANDO CITY CODE TO ESTABLISH DESIGNATED CHILDREN PLAYGROUND AREAS

This item is placed on the agenda by Councilmember Robert C. Gonzales.

SAN FERNANDO CITY COUNCIL

Regular Meeting Notice and Agenda – February 16, 2016

Page 4 of 4

11) CONSIDERATION OF OPPOSITION TO SB 876 (LIU): HOMELESSNESS

Recommend that the City Council provide staff with direction related to the League of California Cities opposition to SB 876 (Liu): Homelessness.

COMMITTEE/COMMISSION LIAISON UPDATES**GENERAL COUNCIL COMMENTS****STAFF COMMUNICATION****ADJOURNMENT**

I hereby certify under penalty of perjury under the laws of the State of California that the foregoing agenda was posted on the City Hall bulletin board not less than 72 hours prior to the meeting.

Elena G. Chávez, CMC

City Clerk

Signed and Posted: February 11, 2015 (3:00 p.m.)

Agendas and complete Agenda Packets (including staff reports and exhibits related to each item) are posted on the City's Internet Web site (www.sfcity.org). These are also available for public reviewing prior to a meeting in the City Clerk's Office. Any public writings distributed by the City Council to at least a majority of the Councilmembers regarding any item on this regular meeting agenda will also be made available at the City Clerk's Office at City Hall located at 117 Macneil Street, San Fernando, CA, 91340 during normal business hours. In addition, the City may also post such documents on the City's Web Site at www.sfcity.org. In accordance with the Americans with Disabilities Act of 1990, if you require a disability-related modification/accommodation to attend or participate in this meeting, including auxiliary aids or services please call the City Clerk's Office at (818) 898-1204 at least 48 hours prior to the meeting.

Regular Meeting

San Fernando City Council

*This Page
Intentionally
Left Blank*

*This Page
Intentionally
Left Blank*

**SAN FERNANDO CITY COUNCIL
MINUTES**

**JANUARY 19, 2016 – 6:00 P.M.
REGULAR MEETING**

City Hall Council Chambers
117 Macneil Street
San Fernando, CA 91340

CALL TO ORDER/ROLL CALL

Mayor Joel Fajardo called the meeting to order at 6:01 p.m.

Present:

Council: Mayor Joel Fajardo, Vice Mayor Sylvia Ballin, and Councilmembers Robert C. Gonzales, Antonio Lopez, and Jaime Soto

Staff: City Manager Brian Saeki, Assistant City Attorney Isabel Birrueta (arrived at 6:31 p.m.) and City Clerk Elena G. Chávez

PLEDGE OF ALLEGIANCE

Led by Mayor Fajardo

APPROVAL OF AGENDA

Motion by Councilmember Lopez, seconded by Vice Mayor Ballin, to approve the agenda. By consensus, the motion carried.

PRESENTATION

The following presentations were made:

- a) 2015 HELP PORTRAIT – RECOGNITION OF PARTICIPANTS
Mayor Joel Fajardo
- b) CERTIFICATE OF APPRECIATION TO JENNIE CAREY (CÉSAR CHÁVEZ
LEARNING ACADEMY)
Mayor Joel Fajardo

SAN FERNANDO CITY COUNCIL**MINUTES – January 19, 2016****Page 2****PUBLIC STATEMENTS – WRITTEN/ORAL**

Jeff Austin gave praise to his colleague and friend, Jennie Carey and said that she went above and beyond her duties and helped many youth in the community.

Jose Navarro also spoke highly of Ms. Carey and said she was instrumental in bringing opportunities and resources to students and making sure that the voices of parents and students were heard.

Dee Akemon talked about a woman that's been missing from the City for several years and asked that Council consider putting up a reward for information. She also stated that 100% of the complaints received by the Transportation & Safety Commission are traffic related.

In response to resident Michelle Guijarro's question, Community Development Director Fred Ramirez replied that the Planning and Preservation Commission meets the first Tuesday of the month.

Mary Mendoza is glad that the moratorium item is back on the agenda, asked when will the palm trees be replaced (or if the City's getting reimbursed), inquired when will the TOD PowerPoint be placed on the City's website, and asked when will the City's quarterly newsletter be distributed.

CONSENT CALENDAR

Motion by Vice Mayor Ballin, seconded by Councilmember Lopez, to approve the Consent Calendar Items:

- 1) REQUEST TO APPROVE MINUTES OF:
 - a. NOVEMBER 16, 2015 – SPECIAL MEETING
 - b. DECEMBER 7, 2015 – SPECIAL MEETING
- 2) CONSIDERATION TO ADOPT RESOLUTION NO.'S 15-122, 16-011 AND 16-012 APPROVING THE WARRANT REGISTERS OF DECEMBER 21, 2015, JANUARY 4, 2016 AND JANUARY 19, 2016 RESPECTIVELY
- 3) CONSIDERATION TO APPROVE NON-EXCLUSIVE LICENSE AGREEMENTS REGARDING BASEBALL FIELDS AND CONCESSION STANDS FOR YOUTH BASEBALL LEAGUES
- 4) CONSIDERATION TO ADOPT A RESOLUTION APPROVING AN ENVIRONMENTALLY PREFERABLE PURCHASING AND PRACTICES POLICY TO ALLOW THE CITY TO ACCESS FUNDING THROUGH THE CALRECYCLE RUBBERIZED PAVEMENT GRANT PROGRAM

SAN FERNANDO CITY COUNCIL**MINUTES – January 19, 2016****Page 3**

- 5) CONSIDERATION TO ADOPT A RESOLUTION AMENDING THE TABLE OF ORGANIZATION FOR FISCAL YEAR (FY) 2015-2016 TO INCLUDE THE CITY CLERK DEPARTMENT
- 6) CONSIDERATION TO APPROVE A PURCHASE ORDER WITH ADVANCED ELECTRONICS INC. FOR THE PURCHASE OF TWO SETS OF MOBILE AUTOMATIC LICENSE PLATE READER (ALPR) CAMERA SYSTEMS
- 7) CONSIDERATION TO APPROVE ON-CALL SERVICES AGREEMENTS FOR STREET STRIPING MAINTENANCE
- 8) CONSIDERATION TO APPROVE ON-CALL MAINTENANCE SERVICES AGREEMENTS FOR UTILITY STREET PATCHING AND POT HOLE REPAIRS
- 9) CONSIDERATION TO APPROVE AN AMENDMENT TO THE ON-CALL MAINTENANCE SERVICES AGREEMENT FOR WASTEWATER FLOW MONITORING SERVICES
- 10) CONSIDERATION TO APPROVE AN AMENDMENT TO THE PROFESSIONAL SERVICES AGREEMENT WITH WILL DAN FINANCIAL SERVICES TO INCLUDE A DEVELOPMENT IMPACT FEE STUDY
- 11) CONSIDERATION TO COMPLETE GRANT FUNDED IMPROVEMENTS AT RECREATION PARK

PUBLIC HEARING

- 12) CONSIDERATION TO ADOPT AN URGENCY ORDINANCE MAKING FINDINGS AND ESTABLISHING AN INTERIM MORATORIUM ON THE APPLICATION FILING, PROCESSING, APPROVAL AND ISSUANCE OF PERMITS FOR MULTIPLE-FAMILY DWELLING PROJECTS

Community Development Director Ramirez presented the staff report and replied to questions from Councilmembers.

Discussion ensued each Councilmember provided their comments.

Mayor Fajardo opened the Public Hearing and called for public testimony.

Jesse Avila said a lot of this could be included in the EIR study.

There being no comments, Mayor Fajardo closed the public comment portion of the Hearing.

Motion by Mayor Fajardo, seconded by Vice Mayor Ballin, to waive full reading and adopt Urgency Ordinance No. U-1650 by title only, "An Urgency Ordinance of the City Council of the City of San Fernando Instituting an Interim Moratorium on the Application Filing, Processing,

SAN FERNANDO CITY COUNCIL**MINUTES – January 19, 2016****Page 4**

Approval and Issuance of Permits for Multiple-Family Dwelling Projects”; with the understanding that this will also include, research, vetting, and cost analysis on hydraulic gaging.

Councilmember Lopez requested a friendly amendment to bring the ordinance back in 45 days (not to exceed six months). At six months, bring it back to the City Council to expedite the process.

The amendment was not accepted by Mayor Fajardo.

The above motion made by Mayor Fajardo, and seconded by Vice Mayor Ballin, carried with the following vote:

AYES: Gonzales, Ballin, Soto, Lopez, Fajardo – 5

NOES: None

COMMITTEE/COMMISSION LIAISON UPDATES

Councilmember Gonzales gave an update regarding Independent Cities Association and reported that the annual conference is coming up.

Councilmember Lopez gave an update regarding Metropolitan Transportation Authority events.

City Clerk Chávez gave an update regarding the activities of the Education Commission and stated that the 2016 scholarship process is underway.

Vice Mayor Ballin gave a brief update regarding the Gabriel Fernandez scholarship.

Mayor Fajardo gave updates regarding the High Speed Rail Ad Hoc and League of California Cities activities.

GENERAL COUNCIL COMMENTS

Councilmember Gonzales wished everyone a happy new year.

Councilmember Lopez welcomed everyone back and is excited for the coming year.

Councilmember Soto said he participated in the distribution of the Christmas baskets and said it was a humbling experience that makes a big impact on the families. He said there is a lot to be done in the City and let’s move forward.

Vice Mayor Ballin said we need to roll up our sleeves; we do have a lot of work to do.

Mayor Fajardo said the Alas Media presentation is one of his favorites; he welcomed everyone back and is looking forward to 2016.

SAN FERNANDO CITY COUNCIL**MINUTES – January 19, 2016****Page 5****STAFF COMMUNICATION**

City Manager Saeki wished everyone a happy new year, said that the quarterly newsletter will be going out soon, and that the six palm trees will be re-planted.

Community Development Director Ramirez said that the scoping meeting PowerPoint presentation will be up on the website soon and the City's homeless count event is coming up (Los Angeles County cities are participating).

Recreation and Community Services Director Ismael Aguila invited everyone to attend the upcoming Los Angeles County community meeting regarding Countywide Park Needs Assessment at Las Palmas Park.

ADJOURNMENT (7:15 P.M.)

Motion by Councilmember Gonzales, seconded by Mayor Fajardo, to adjourn the meeting. By consensus, the motion carried.

I do hereby certify that the foregoing is a true and correct copy of the minutes of January 19, 2016, meeting as approved by the San Fernando City Council.

Elena G. Chávez
City Clerk

*This Page
Intentionally
Left Blank*

2

*This Page
Intentionally
Left Blank*



AGENDA REPORT

To: Mayor Joel Fajardo and Councilmembers

From: Brian Saeki, City Manager
By: Nick Kimball, Finance Director

Date: February 16, 2016

Subject: Consideration to Adopt Resolution No. 16-022- Approving the Warrant Register

RECOMMENDATION:

It is recommended that the City Council adopt Resolution No. 16-022 (Attachment "A") approving the Warrant Register.

BACKGROUND:

For each City Council meeting the Finance Department prepares a Warrant Register for Council approval. The Register includes all recommended payments for the City. Checks, other than handwritten checks, generally are not released until after the Council approves the Register. The exceptions are for early releases to avoid penalties and interest, excessive delays and in all other circumstances favorable to the City to do so. Handwritten checks are those payments required to be issued between Council meetings such as insurance premiums and tax deposits. Staff reviews requests for expenditures for budgetary approval and then prepares a Warrant Register for Council approval and or ratification. Items such as payroll withholding tax deposits do not require budget approval.

The Finance Director hereby certifies that all requests for expenditures have been signed by the department head, or designee, receiving the merchandise or services thereby stating that the items or services have been received and that the resulting expenditure is appropriate. The Finance Director hereby certifies that each warrant has been reviewed for completeness and that sufficient funds are available for payment of the warrant register.

ATTACHMENT:

A. Resolution No. 16-022

ATTACHMENT "A"

RESOLUTION NO. 16-022

RESOLUTION OF THE CITY COUNCIL OF THE CITY OF SAN FERNANDO ALLOWING AND APPROVING FOR PAYMENT DEMANDS PRESENTED ON DEMAND/ WARRANT REGISTER NO. 16-022

THE CITY COUNCIL OF THE CITY OF SAN FERNANDO DOES HEREBY RESOLVE, FIND, DETERMINE AND ORDER AS FOLLOWS:

1. That the demands (EXHIBIT "A") as presented, having been duly audited, for completeness, are hereby allowed and approved for payment in the amounts as shown to designated payees and charged to the appropriate funds as indicated.

2. That the City Clerk shall certify to the adoption of this Resolution and deliver it to the City Treasurer.

PASSED, APPROVED, AND ADOPTED this 16th day of February, 2016.

Joel Fajardo, Mayor

ATTEST:

Elena G. Chávez, City Clerk

STATE OF CALIFORNIA)
COUNTY OF LOS ANGELES) ss
CITY OF SAN FERNANDO)

I HEREBY CERTIFY that the foregoing Resolution was approved and adopted at a regular meeting of the City Council held on the 16th day of February, 2016, by the following vote to wit:

AYES:

NOES:

ABSENT:

Elena G. Chávez, City Clerk

EXHIBIT "A"

vchlist Page: 1
 02/10/2016 4:51:46PM Voucher List
 CITY OF SAN FERNANDO

Bank code : bank3

Voucher	Date	Vendor	Invoice	PO #	Description/Account	Amount
200005	2/16/2016	892033 A PANORAMA FLOWERS	020216		PLANTS - SENIOR CLUB EVENT 004-2380	1,078.69
			020216-2		PLANTS - SENIOR CLUB EVENT 004-2380	108.70
					Total :	1,187.39
200006	2/16/2016	891587 ABLE MAILING INC.	23603	11238	FULFILLMENT; FOLD TWO PCS, INSER 070-382-0000-4300	65.68
			23604	11238	072-360-0000-4300	65.68
					STORAGE OF WATER ENVELOPES-JAN 070-382-0000-4300	12.50
					072-360-0000-4300	12.50
					Total :	156.36
200007	2/16/2016	100066 ADS ENVIRONMENTAL SERVICES,INC	22101.22-0116	11266	FY 15-16 DESIGN, INSTALLATION & MO 072-360-0000-4260	1,555.00
					Total :	1,555.00
200008	2/16/2016	888356 ADVANCED AUTO REPAIR BODY &	1007		REPLACE INTAKE MANDIFOLD & HEAD 041-320-0225-4400	1,254.23
			1008		CHARGE A/C; ALIGN FRONT DOORS - F 041-320-0371-4400	152.85
			1009		REPLACE BROKEN RIGHT REAR DOOF 070-384-0000-4400	285.00
			1010		REPLACE BROKEN DOOR GLASS - PKI 041-320-0390-4400	209.50
					Total :	1,901.58
200009	2/16/2016	100070 ADVANCED ELECTRONICS INC.	80000755	11239	COMPUTER MAINTENANCE - FEB 2016 001-135-0000-4260	6,761.57
					Total :	6,761.57
200010	2/16/2016	891969 ADVANCED PURE WATER SOLUTIONS	36495711-0216		DRINKING WATER 001-222-0000-4300	102.33
					Total :	102.33

vchlist Page: 2
 02/10/2016 4:51:46PM Voucher List
 CITY OF SAN FERNANDO

Bank code : bank3

Voucher	Date	Vendor	Invoice	PO #	Description/Account	Amount
200011	2/16/2016	100098 AIRGAS SAFETY	9047106698		SAFETY GLASSES 072-360-0000-4310	48.03
			9047106699		SAFETY EQUIPMENT 072-360-0000-4310	565.82
			9047304279		SAFETY GEAR 072-360-0000-4310	13.21
					Total :	627.06
200012	2/16/2016	887377 AKEMON, DOLORES	FEB 2016		COMMISSIONER'S REIMB 001-310-0000-4111	50.00
					Total :	50.00
200013	2/16/2016	891739 ALAS MEDIA	201536		COUNCILMEMBER SOTO HEADSHOT-F 001-190-0000-4267	60.00
					Total :	60.00
200014	2/16/2016	100143 ALONSO, SERGIO	JAN 2016		MMAPI INSTRUCTOR 109-424-3637-4260	750.00
					Total :	750.00
200015	2/16/2016	888707 AMERICAN SOCIETY OF COMPOSERS,	500623477		ANNUAL MUSIC LICENSE 001-420-0000-4260	336.08
					Total :	336.08
200016	2/16/2016	100222 ARROYO BUILDING MATERIALS, INC	160728		GLENOAKS & MACLAY - FILL IN TREE V 001-311-0301-4300	192.07
			160784		GLENOAKS & MACLAY - FILL IN TREE V 001-311-0301-4300	108.01
					Total :	300.08
200017	2/16/2016	892014 BERNAL, DAVID	FEB 2016		COMMISSIONER'S REIMBURSEMENT 001-150-0000-4111	50.00
					Total :	50.00
200018	2/16/2016	890999 BERRIOZABAL, GILBERT	FEB 2016		COMMISSIONER'S REIMBURSEMENT 001-310-0000-4111	50.00
					Total :	50.00

vchlist		Voucher List				Page:	3
02/10/2016 4:51:46PM		CITY OF SAN FERNANDO					
Bank code : bank3							
Voucher	Date	Vendor	Invoice	PO #	Description/Account	Amount	
200019	2/16/2016	100405 BONANZA CONCRETE, INC.	51599		DRIVEWAY APPROACH - 532 NEWTON 001-311-0301-4300	733.65	
					Total :	733.65	
200020	2/16/2016	889274 BOWDEN MORENO, LINDA	REIMB.		MILEAGE REIMB 001-420-0000-4370	81.62	
					Total :	81.62	
200021	2/16/2016	888800 BUSINESS CARD	012016		REGISTRATION - APA 2016 NATIONAL 001-105-0000-4370	735.00	
			012516		APA 2016 NATIONAL PLANNING CONFE 001-105-0000-4370	740.97	
			012516		BENCHES FOR GYM 017-420-1328-4300	2,271.80	
			012816		DESSERT FOR ORAL BOARD 001-106-0000-4270	14.99	
			012916		MISC CHARGES 001-190-0000-4435	124.58	
			012916		LUNCH FOR ORAL BOARD 001-106-0000-4270	65.06	
			020216		REGISTRATION -04/10/16-04/14/16 IN 001-105-0000-4360	60.00	
					Total :	4,012.40	
200022	2/16/2016	100461 BYRD ELECTRONICS CORP.	109-16		SCADA REPAIRS - VARIOUS SITES 070-384-0000-4260	1,168.28	
					Total :	1,168.28	
200023	2/16/2016	100466 CACEO	200002091		COURSE REGISITRATION-CA MOLD UF 001-152-0000-4370	15.00	
			200002092		REFRESHER COURSE REGISTRATION 001-152-0000-4370	50.00	
			200002095		SEMINAR REGISTRATION-INTRO TO PI 001-152-0000-4370	50.00	
			300001894		ANNUAL MEMBERSHIP DUES 001-152-0000-4380	85.00	
			300002002		ANNUAL MEMBERSHIP		
Page: 3							

vchlist		Voucher List				Page:	4
02/10/2016 4:51:46PM		CITY OF SAN FERNANDO					
Bank code : bank3							
Voucher	Date	Vendor	Invoice	PO #	Description/Account	Amount	
200023	2/16/2016	100466 CACEO	(Continued)		001-152-0000-4380	85.00	
					Total :	285.00	
200024	2/16/2016	887810 CALGROVE RENTALS, INC.	61995		BOOM LIFT RENTAL FOR BIKEWAY SOI 043-390-0000-4250	702.00	
					Total :	702.00	
200025	2/16/2016	103619 CARL WARREN & CO.	1724147		LEGAL FEES 006-190-0000-4800	375.00	
					Total :	375.00	
200026	2/16/2016	891860 CARL WARREN & COMPANY	10072-10086		REIMB. TO ITF ACCT (LIABILITY CLAIMS) 006-1037	28,442.93	
					Total :	28,442.93	
200027	2/16/2016	100472 CCAC	1120		CITY CLERKS ASSOC MEMBERSHIP DI 001-115-0000-4380	185.00	
					Total :	185.00	
200028	2/16/2016	891711 CHIEF LAW ENFORCEMENT SUPPLY	412127		DUTY JACKETS 001-222-0000-4300	279.95	
			447258		REFLECTIVE SAFETY VESTS FOR CRC 001-222-0000-4300	242.17	
					Total :	522.12	
200029	2/16/2016	101957 CITY OF LOS ANGELES	38SF160000007		FIRE SERVICES - JAN 2016 001-500-0000-4260	241,300.50	
					Total :	241,300.50	
200030	2/16/2016	888038 CLEARS, INC.	2016		2016 MEMBERSHIP DUES 001-222-0000-4380	50.00	
					Total :	50.00	
200031	2/16/2016	100752 COLELLI, CHRIS	TRAVEL		MANDATORY STC COURSE - INCARCE 001-225-3688-4360	75.00	
					Total :	75.00	
Page: 4							

vchlist		Voucher List				Page:	5
02/10/2016 4:51:46PM		CITY OF SAN FERNANDO					
Bank code : bank3							
Voucher	Date	Vendor	Invoice	PO #	Description/Account	Amount	
200032	2/16/2016	100805 COOPER HARDWARE INC.	98915		CHALK, CLAMP CONNECTORS, NUTS, 041-320-0000-4320	27.95	
			98939		CLAMP & CEMENT 041-320-0000-4320	27.50	
					Total :	55.45	
200033	2/16/2016	100491 CPS HR CONSULTING	SOP40888		SGT TESTING MATERIALS 001-106-0000-4270	442.20	
					Total :	442.20	
200034	2/16/2016	889794 CUELLAR, JULIE	FEB 2016		COMMISSIONER'S REIMB 001-310-0000-4111	50.00	
					Total :	50.00	
200035	2/16/2016	887475 DATA BUSINESS SYSTEMS, INC	105536		2015 W2'S, 1099'S & 1098'S 001-130-0000-4300	210.46	
					Total :	210.46	
200036	2/16/2016	888075 DATAMATIC, INC.	SRV16012439		HANDHELD METER READING MAINT - I 070-381-0000-4370	395.08	
					Total :	395.08	
200037	2/16/2016	887121 DELL MARKETING L.P.	XJW5M71J5	11308	LAPTOP AND SOFTWARE FOR A DETE 021-222-0000-4500	253.01	
			XJW6F4J15	11308	LAPTOP AND SOFTWARE FOR A DETE 021-222-0000-4500	1,028.92	
					Total :	1,281.93	
200038	2/16/2016	888056 DOWNTOWN FORD SALES	234793	11158	HEAVY DUTY UTILITY TRUCK REPLAC 070-383-0000-4500	114,302.31	
				11158	070-383-0000-4600	3,311.69	
				11158	070-383-0000-4500	11,283.83	
					Total :	128,897.83	
200039	2/16/2016	887518 DURHAM, ALVIN	FEB 2016		COMMISSIONER'S REIMBURSEMENT 001-150-0000-4111	50.00	
					Total :	50.00	
						Page:	5

vchlist		Voucher List				Page:	6
02/10/2016 4:51:46PM		CITY OF SAN FERNANDO					
Bank code : bank3							
Voucher	Date	Vendor	Invoice	PO #	Description/Account	Amount	
200040	2/16/2016	890401 ENVIROGEN TECHNOLOGIES INC	0007691-IN	11254	JAN'16-NITRATE REMOVAL SYSTEM LE 070-384-0000-4260	7,206.65	
					Total :	7,206.65	
200041	2/16/2016	890879 EUROFINS EATON ANALYTICAL, INC	L0245567		WATER ANALYSIS FOLDERS 070-384-0000-4260	139.60	
			L0245570		WATER ANALYSIS FOLDERS 070-384-0000-4260	139.60	
			L0245751		WATER ANALYSIS FOLDERS 070-384-0000-4260	139.60	
			L0246880		WATER ANALYSIS FOLDERS 070-384-0000-4260	139.60	
			L0246881		WATER ANALYSIS FOLDERS 070-384-0000-4260	139.60	
			L0246883		WATER ANALYSIS FOLDERS 070-384-0000-4260	139.60	
			L0246886		WATER ANALYSIS FOLDERS 070-384-0000-4260	268.80	
			L0246891		WATER ANALYSIS FOLDERS 070-384-0000-4260	139.60	
			L0247347		WATER ANALYSIS FOLDERS 070-384-0000-4260	164.00	
			L0247348		WATER ANALYSIS FOLDERS 070-384-0000-4260	139.60	
			L0247821		WATER ANALYSIS FOLDERS 070-384-0000-4260	139.60	
			L024882		WATER ANALYSIS FOLDERS 070-384-0000-4260	139.60	
			L0249058		WATER ANALYSIS FOLDERS 070-384-0000-4260	139.60	
					Total :	1,968.40	
200042	2/16/2016	890897 EVAN BROOKS ASSOCIATES, INC	150010-2	11291	MSRC LOCAL GOVERNMENT MATCH P 001-310-0000-4270	12,510.00	
			16001-1	11321	CONTRACT PLANNER SERVICES 001-150-0000-4270	7,980.00	
			16002-4		CONTRACT PLANNER SERVICES		
						Page:	6

vchlist		Voucher List				Page:	7
02/10/2016 4:51:46PM		CITY OF SAN FERNANDO					
Bank code : bank3							
Voucher	Date	Vendor	Invoice	PO #	Description/Account	Amount	
200042	2/16/2016	890897 EVAN BROOKS ASSOCIATES, INC	(Continued)	11321	001-150-0000-4270	4,860.00	
			16002-6	11229	ENG DESIGN SERVICES FOR SAFE RC	8,850.00	
					010-370-3636-4600		Total : 34,200.00
200043	2/16/2016	103851 EVERSOFIT, INC.	R1535000		SOFTNER - WELL 2A	72.22	
					070-384-0000-4260		Total : 72.22
200044	2/16/2016	891622 FARMER BROTHERS	63132791		BREAKROOM SUPPLIES	102.96	
					001-222-0000-4300		Total : 102.96
200045	2/16/2016	101147 FEDEX	5-303-24664		COURIER SERVICE	54.98	
					001-190-0000-4280		Total : 54.98
200046	2/16/2016	889328 FIRST TRANSIT, INC.	11175631		MCT - DEC 2015	23,942.16	
					007-440-0442-4260	-440.06	
					007-3794-0000	20,737.78	
					008-313-0000-4260	-1,261.67	
					007-3794-3630		Total : 42,978.21
200047	2/16/2016	889532 GILMORE, REVA.A.	01/23/16 - 02/05/16		FOOD SERVICE MANAGER	552.50	
					115-422-3750-4270	78.00	
					115-422-3752-4270		Total : 630.50
200048	2/16/2016	891664 GOLDEN TOUCH CLEANING, INC	62385	11242	JAN'16-JANITORIAL SERVICES CONTR.	12,550.00	
					043-390-0000-4260		Total : 12,550.00
200049	2/16/2016	889535 GOMEZ, GILBERT	01/23/16 - 02/05/16		HDM DRIVER	140.00	
					115-422-3752-4270	36.40	
					115-422-3752-4390		
							Page: 7

vchlist		Voucher List				Page:	8
02/10/2016 4:51:46PM		CITY OF SAN FERNANDO					
Bank code : bank3							
Voucher	Date	Vendor	Invoice	PO #	Description/Account	Amount	
200049	2/16/2016	889535 889535 GOMEZ, GILBERT	(Continued)				Total : 176.40
200050	2/16/2016	101376 GRAINGER, INC.	9004076668		REC PARK DRINKING FOUNTAIN	1,748.72	
			9007386577		043-390-0000-4300	70.10	
					SAFETY VESTS		Total : 1,818.82
					043-390-0000-4310		
200051	2/16/2016	892138 GUARDIAN ENCLOSURES, LLC.	GE0468		BACKFLOW ENCLOSURE - BRAND ISL	359.12	
					070-383-0000-4300		Total : 359.12
200052	2/16/2016	101671 GUZMAN, DANETTE	TRAVEL		MANDATORY STC COURSE FOR CRISI	135.00	
					001-225-3688-4360		Total : 135.00
200053	2/16/2016	101434 GUZMAN, JESUS ALBERTO	JAN 2016		MMAP INSTRUCTOR	1,800.00	
					109-424-3637-4260		Total : 1,800.00
200054	2/16/2016	891053 HAUPT, THEALE E	FEB 2016		COMMISSIONER'S REIMBURSEMENT	50.00	
					001-150-0000-4111		Total : 50.00
200055	2/16/2016	888646 HD SUPPLY WATER WORKS, LTD	E894843		BALLCORP FOR AIR VAC WELL 7A	229.89	
					041-320-0000-4320		Total : 229.89
200056	2/16/2016	890594 HEALTH AND HUMAN RESOURCE	135264		EAP - FEB 2016	235.30	
					001-106-0000-4260		Total : 235.30
200057	2/16/2016	101599 IMAGE 2000 CORPORATION	7679		ASCEP FREIGHT CHARGE	6.50	
			VN443615		103-420-0000-4260	6.50	
			VN472066		104-420-0000-4260		
					FREIGHT FOR COPIER TONER	13.00	
					041-320-0000-4300		
					VARIOUS COPIERS CONTRACT USAGE		
							Page: 8

vchlist		Voucher List				Page:	9
02/10/2016 4:51:46PM		CITY OF SAN FERNANDO					
Bank code : bank3							
Voucher	Date	Vendor	Invoice	PO #	Description/Account	Amount	
200057	2/16/2016	101599 IMAGE 2000 CORPORATION	(Continued)		103-420-0000-4260	44.99	
					104-420-0000-4260	44.98	
					001-135-0000-4260	612.77	
					072-360-0000-4450	34.69	
					001-135-0000-4260	115.45	
					Total :	878.88	
200058	2/16/2016	891570 INNOVATIVE TELECOM. SYSTEMS	1677		CONSULT ON EOC ISSUES AND ANALC		
					001-190-0000-4260	527.50	
			1723	11311	001-190-0000-4300	572.25	
					PHONE SYSTEM UPGRADE - INSTALL		
					001-190-0000-4300	3,473.91	
					001-190-0000-4300	207.10	
					Total :	4,780.76	
200059	2/16/2016	101647 INTERSTATE BATTERY	30066264		BATTERY FOR FLEET		
					041-1215	259.46	
					Total :	259.46	
200060	2/16/2016	891777 IRRIGATION EXPRESS	15038967-00		MATL'S FOR WELL 7A AIR RELEASE VA		
			15039068-00		041-320-0000-4320	329.64	
			15039668-00		IRRIGATION REPAIRS @ LP PARK		
			15039668-00		043-390-0000-4300	50.89	
			15040270-00		MATL'S FOR WELL 7A AIR RELEASE VA		
			15040530-00		041-320-0000-4320	25.03	
					MALL IRRIGATION REPAIR		
					001-311-0000-4300	36.54	
					IRRIGATION REPAIRS @ LP PARK BASI		
					043-390-0000-4300	20.25	
					Total :	462.35	
200061	2/16/2016	887952 J. Z. LAWNMOWER SHOP	12073		SMALL TOOLS		
					043-390-0000-4340	67.53	
					Total :	67.53	
200062	2/16/2016	889680 JIMENEZ LOPEZ, JUAN MANUEL	JAN 2016		MMAP INSTRUCTOR		
						Page:	9

vchlist		Voucher List				Page:	10
02/10/2016 4:51:46PM		CITY OF SAN FERNANDO					
Bank code : bank3							
Voucher	Date	Vendor	Invoice	PO #	Description/Account	Amount	
200062	2/16/2016	889680 JIMENEZ LOPEZ, JUAN MANUEL	(Continued)		109-424-3637-4260	450.00	
					108-424-3659-4260	450.00	
					Total :	900.00	
200063	2/16/2016	891008 JONES, KENNETH	REIMB		MILEAGE REIMB. AQMD TRAINING		
					001-310-0000-4390	54.54	
					Total :	54.54	
200064	2/16/2016	102387 K.R. NIDA CORPORATION	27496		HANDHELD RADIO REPAIR - SVC 10		
			27523		001-346-0000-4260	95.00	
			27550		CE HANDHELD RADIOS SERVICED		
					001-152-0000-4260	390.00	
					REPLACEMENT BATTERY - SVC 10		
					001-346-0000-4300	79.03	
					Total :	564.03	
200065	2/16/2016	892137 KING'S BRAKE & SUSPENSION	006014		CHECK/SERVICE BRAKES; MOUNT & B		
			006039		072-360-0000-4400	241.03	
					REPLACE FRONT & REAR BRAKES - PI		
					041-320-0370-4400	793.00	
					Total :	1,034.03	
200066	2/16/2016	890463 KJC LATENT PRINT SERVICE	SF00028		FINGERPRINTING CLASSIFICATION		
					001-224-0000-4270	150.00	
					Total :	150.00	
200067	2/16/2016	891738 KNIGHT COMMUNICATIONS INC	2010616	11249	INFORMATION TECHNOLOGY MANAGE		
					001-135-0000-4270	10,000.00	
					Total :	10,000.00	
200068	2/16/2016	101990 L.A. COUNTY METROPOLITAN	800062688		TAP CARDS - DEC 2015		
					007-440-0441-4260	720.00	
					Total :	720.00	
200069	2/16/2016	101852 LARRY & JOE'S PLUMBING	2668807-0001-02		MATL'S FOR PLUMBING REPAIR @ CIT		
					043-390-0000-4300	24.73	
						Page:	10

vchlist		Voucher List				Page: 11	
02/10/2016 4:51:46PM		CITY OF SAN FERNANDO					
Bank code : bank3							
Voucher	Date	Vendor	Invoice	PO #	Description/Account	Amount	
200069	2/16/2016	101852 101852 LARRY & JOE'S PLUMBING	(Continued)				Total : 24.73
200070	2/16/2016	892079 LENNOX INDUSTRIES	549113697	11307 11307	HVAC UNIT FOR CITY HALL & REC PAR 043-390-0000-4500 118-423-0000-4500	3,217.51 41,305.50	Total : 44,523.01
200071	2/16/2016	101920 LIEBERT CASSIDY WHITMORE	1415333 1415334 1415335		LEGAL SERVICES 001-112-0000-4270 LEGAL SERVICES 001-112-0000-4270 LEGAL SERVICES 001-112-0000-4270	682.50 2,531.50 2,524.50	Total : 5,738.50
200072	2/16/2016	101929 LINGO INDUSTRIAL ELECTRONICS	32307 32308 32310		TRAFFIC SIGNAL KNOCK DOWN POLE 001-371-0301-4300 VISOR REPLACEMENT 001-371-0301-4300 CONFLICT MONITOR REPLACEMENT 001-371-0301-4300	795.70 81.75 1,167.39	Total : 2,044.84
200073	2/16/2016	889423 LIZARRAGA, MANUEL	TRAVEL		MANDATORY STC COURSE FOR CRISI 001-225-3688-4360	135.00	Total : 135.00
200074	2/16/2016	888468 MAJOR METROPOLITAN SECURITY	1075486 2094		ALARM MONITORING - 12900 DRONFIE 070-384-0000-4260 INSTALLATION OF (3) WIRELESS PANIC 043-390-0000-4330	23.00 550.00	Total : 573.00
200075	2/16/2016	887918 MARISCAL JR, MARIO	TRAVEL		MANDATORY STC COURSE - INCARCE 001-225-3688-4360	75.00	Total : 75.00
200076	2/16/2016	889533 MARTINEZ, ANITA	01/23/16 - 02/05/16		FOOD SERVICE INTAKE CLERK-C1		
							Page: 11

vchlist		Voucher List				Page: 12	
02/10/2016 4:51:46PM		CITY OF SAN FERNANDO					
Bank code : bank3							
Voucher	Date	Vendor	Invoice	PO #	Description/Account	Amount	
200076	2/16/2016	889533 MARTINEZ, ANITA	(Continued)		115-422-3750-4270	160.00	Total : 160.00
200077	2/16/2016	102142 MATTHEW BENDER & CO., INC.	79545246 79545254		PENAL & VEHICLE CODE BOOKS 001-222-0000-4300 PENAL & VEHICLE CODE BOOKS 001-222-0000-4300	306.67 124.75	Total : 431.42
200078	2/16/2016	888242 MCI COMM SERVICE	7DK54968		MTA PHONE LINES 007-440-0441-4220	33.70	Total : 33.70
200079	2/16/2016	891054 MEJIA, YVONNE G	FEB 2016		COMMISSIONER'S REIMBURSEMENT 001-150-0000-4111	50.00	Total : 50.00
200080	2/16/2016	102177 MENDOZA, SALVADOR	010416		MUSIC FOR SR CLUB DANCE ON 02/20 004-2380	900.00	Total : 900.00
200081	2/16/2016	102201 MIERZYNSKI, IRMGARD	NOV 2015 - JAN 2016		LINE DANCE INSTRUCTOR 017-420-1339-4260	140.00	Total : 140.00
200082	2/16/2016	888264 MISSION VALLEY SANITATION	135080		PORTABLE TOILET RENTAL @ 12900 D 043-390-0000-4260	136.96	Total : 136.96
200083	2/16/2016	103910 MONTGOMERY HARDWARE COMPANY	209290		DOOR CLOSER FOR MEN'S RESTROOI 043-390-0000-4300	316.29	Total : 316.29
200084	2/16/2016	891542 MR "B" PRINTING INC.	33877		FLYER DISTRIBUTION 017-420-1396-4260	654.00	Total : 654.00
							Page: 12

vchlist		Voucher List				Page:	13
02/10/2016	4:51:46PM	CITY OF SAN FERNANDO					
Bank code : bank3							
Voucher	Date	Vendor	Invoice	PO #	Description/Account	Amount	
200085	2/16/2016	102287 MUNICIPAL CODE CORPORATION	00265630		SUPPLEMENTAL PAGES TO THE CODE 001-115-0000-4260	4,173.85 Total : 4,173.85	
200086	2/16/2016	102303 NACHO'S ORNAMENTAL SUPPLY	INV077086		MATL'S FOR POLICE TRASH GATE 043-390-0000-4300	146.36 Total : 146.36	
200087	2/16/2016	102325 NAPA AUTO PARTS	886550 887622		TIRE MONITOR UPDATE 041-320-0000-4340 YELLOW STOBE - PK0935 041-320-0390-4400	168.66 85.34 Total : 254.00	
200088	2/16/2016	891355 NAREZ, FABIAN	JAN 2016		MMAP MENTOR INSTRUCTOR 109-424-3637-4260	180.00 Total : 180.00	
200089	2/16/2016	101761 NCCA/KEYS CONFERENCE	TRAVEL		REGISTRATION - MANDATORY STC CC 001-225-3688-4360	399.00 Total : 399.00	
200090	2/16/2016	101761 NCCA/KEYS CONFERENCE	TRAVEL		REGISTRATION - MANDATORY STC CC 001-225-3688-4360	399.00 Total : 399.00	
200091	2/16/2016	101761 NCCA/KEYS CONFERENCE	TRAVEL		REGISTRATION - MANDATORY STC CC 001-225-3688-4360	399.00 Total : 399.00	
200092	2/16/2016	102374 NEOPOST	53628023		ANNUAL POSTAGE METER RENTAL 001-190-0000-4280	2,551.44 Total : 2,551.44	
200093	2/16/2016	102366 NEUMANN, DWIGHT PH.D.	TODDN010716		TRANSLATION SERVICES FOR TOD ME 001-150-0000-4270	200.00 Total : 200.00	
						Page: 13	

vchlist		Voucher List				Page:	14
02/10/2016	4:51:46PM	CITY OF SAN FERNANDO					
Bank code : bank3							
Voucher	Date	Vendor	Invoice	PO #	Description/Account	Amount	
200094	2/16/2016	102432 OFFICE DEPOT	18898198691 1889819888 1893303108 1893705547 1894833957 816247105001 816247105002 816329315001 816609994001 817187324001 817627403001 817697478001 818277796001 818278719001 818278720001 819207066001 81926595001 819266231001		OFFICE SUPPLIES 001-140-0000-4300 ASCEP SUPPLIES 103-420-0000-4300 104-420-0000-4300 DESKPAD & PENS 001-310-0000-4300 SHEET PROTECTORS, DIVIDERS, LABI 001-222-0000-4300 PENS, PENCILS, HIGHLIGHTERS, CALE 001-222-0000-4300 OFFICE SUPPLIES 001-140-0000-4300 RAILS FOR CABINET 001-150-0000-4300 BREAKROOM SUPPLIES 070-383-0000-4300 ENVELOPES, DESKPAD, ETC 001-310-0000-4300 CREDIT ITEMS RETURNED 001-222-0000-4300 CREDIT - DESKPAD RETURNED 001-310-0000-4300 TUBES FOR PLANS 001-310-0000-4300 PENS, COPY PAPER, NOTE PADS 001-222-0000-4300 SUPPLIES 001-222-0000-4300 PENS 001-222-0000-4300 VIEW BINDERS, PENS, FOLDERS & SH 041-320-0000-4300 043-390-0000-4300 FILE CABINET 001-105-0000-4300 MEASURING TAPE	6.10 91.15 91.14 30.78 91.99 214.90 44.62 26.49 26.82 103.49 -11.34 -16.63 162.04 365.40 9.40 10.72 103.63 200.00 82.11	
						Page: 14	

vchlist		Voucher List				Page:	15
02/10/2016 4:51:46PM		CITY OF SAN FERNANDO					
Bank code : bank3							
Voucher	Date	Vendor	Invoice	PO #	Description/Account	Amount	
200094	2/16/2016	102432 OFFICE DEPOT	(Continued)				
			819567767001		001-105-0000-4300 DVD+R DISCS		6.34
			819567890001		001-222-0000-4300 BINDERS		83.20
			819567891001		001-222-0000-4300 LETTER HOLDER RACK		134.69
			819585236001		001-222-0000-4300 CREDIT FOR RETURNED FOLDERS		76.64
			8200899717001		043-390-0000-4300 ADDING TAPE, DUSTERS, THERMAL T ²		-56.12
			820151366001		001-130-0000-4300 BATTERIES, PENS, ETC		131.07
			820499715001		001-105-0000-4300 ARM ADJUSTER FOR COMP MONITOR		64.89
			820639815001		001-222-0000-4300 FILE STORAGE BOXES		211.47
			820894440001		001-222-0000-4300 PENS, PAPER, RULERS, ETC		130.39
			820894553001		001-150-0000-4300 OFFICE SUPPLIES		160.67
					001-150-0000-4300		55.47
					Total :		2,631.52
200095	2/16/2016	102443 OKAFOR, MICHAEL	REIMB.		REIMB OF SNACKS PURCHASED FOR		
					001-106-0000-4270		9.80
					001-106-0000-4390		50.11
					Total :		59.91
200096	2/16/2016	891836 OLIVAREZ MADRUGA, LLP	13345		LEGAL SERVICES		
			13407		001-110-0000-4270		37,676.09
					LEGAL SERVICES		
					001-110-0000-4270		19,537.37
					001-110-0098-4270		440.00
					Total :		57,653.46
200097	2/16/2016	891902 P.F. SERVICES INC.	12082		INSPECTION OF DRAGON VALVES ONI		

vchlist		Voucher List				Page:	16
02/10/2016 4:51:46PM		CITY OF SAN FERNANDO					
Bank code : bank3							
Voucher	Date	Vendor	Invoice	PO #	Description/Account	Amount	
200097	2/16/2016	891902 P.F. SERVICES INC.	(Continued)				
					041-320-3661-4400		1,304.28
					Total :		1,304.28
200098	2/16/2016	892023 PAETEC	5726123		PHONE SERVICE 01/18/16-02/17/16		
					001-222-0000-4220		643.31
					001-420-0000-4220		944.29
					001-190-0000-4220		1,806.02
					070-384-0000-4220		488.77
					Total :		3,882.39
200099	2/16/2016	102624 PITNEY BOWES	881950		MAINTENANCE FOR FOLDING MACHIN		
					070-381-0000-4320		337.35
					072-360-0000-4320		337.35
					Total :		674.70
200100	2/16/2016	887646 PLUMBERS DEPOT INC	PD-30420	11189	2014 MODEL 800-HF ECO TRUCK-MOU		
					072-360-0000-4500		219,730.00
					072-360-0000-4500		20,874.35
					Total :		240,604.35
200101	2/16/2016	103912 POWELL, RON	42		DIGITAL HDTV ANTENNA & INSTALLATI		
					001-222-0000-4320		75.80
					Total :		75.80
200102	2/16/2016	890584 POWERLINE BATTERY SPECIALIST	13033		DEPARTMENT SUPPLIES		
			13071		041-320-0000-4300		134.27
					041-1215		208.00
					CNG STATION DISPENSER BATTERY		
					041-320-3661-4400		30.08
					Total :		372.35
200103	2/16/2016	102666 PREFERRED DELIVERY SYSTEMS INC	549-135		COURIER SERVICE		
			549-136		001-222-0000-4260		334.00
					COURIER SERVICES		
					001-222-0000-4260		103.00
					Total :		437.00

vchlist		Voucher List				Page:	17
02/10/2016 4:51:46PM		CITY OF SAN FERNANDO					
Bank code : bank3							
Voucher	Date	Vendor	Invoice	PO #	Description/Account	Amount	
200104	2/16/2016	102731 QUICK CRETE PRODUCTS CORP.	0102642-IN	11219	REPLACEMENT DECORATIVE CONCRE 001-341-0000-4500	1,504.20 Total : 1,504.20	
200105	2/16/2016	892139 QUINTERO, AGUSTIN	2000224.001		YOUTH BASKETBALL REFUND 017-3770-1328	80.00 Total : 80.00	
200106	2/16/2016	102773 RAMIREZ, FEDERICO	REIMB.		REIMB FOR REGISTRATION FEE - SEM 001-150-0000-4370	80.00 Total : 80.00	
200107	2/16/2016	891847 RAMIREZ, JESSICA	REPLACE 109704		REPL STL DTD CK - MILEAGE REIMB. 001-2140	25.50 Total : 25.50	
200108	2/16/2016	889602 RESPOND SYSTEMS	99089		SAFETY GLOVES 001-311-0000-4310	216.91 Total : 216.91	
200109	2/16/2016	891377 REYES, JOSE	01/23/16 - 02/05/16		HDM DRIVER 115-422-3752-4270 115-422-3752-4390	200.00 62.40 Total : 262.40	
200110	2/16/2016	888740 RIVERA INTERPRETING, INC	1037		CERTIFIED INTERPRETER FOR COMM 017-420-1396-4260	300.00 Total : 300.00	
200111	2/16/2016	891121 RIVERA, NICOLE	JAN 2016		MMAP MENTOR INSTRUCTOR 109-424-3637-4260	180.00 Total : 180.00	
200112	2/16/2016	102930 ROYAL WHOLESALE ELECTRIC	8901-723519 8901-724661 8901-724718		WELL SITE CABLES FOR GENERATOR 070-384-0000-4330 REPLACEMENT LADDER 001-371-0301-4300 LADDER STICKERS "OSHA"	1,648.08 324.82	
						Page: 17	

vchlist		Voucher List				Page:	18
02/10/2016 4:51:46PM		CITY OF SAN FERNANDO					
Bank code : bank3							
Voucher	Date	Vendor	Invoice	PO #	Description/Account	Amount	
200112	2/16/2016	102930 ROYAL WHOLESALE ELECTRIC	(Continued) 8901-724929		001-371-0301-4300 STREET LIGHT FUSES 027-344-0301-4300	8.01 226.61 Total : 2,207.52	
200113	2/16/2016	890362 RTB BUS LINE	15521		TRANS SERVICES-VOLUNTEER (CIT) F 007-440-0443-4260	750.00 Total : 750.00	
200114	2/16/2016	889383 RUVALCABA, JAVIER	TRAVEL		MANDATORY STC COURSE - INCARCE 001-225-3688-4360	75.00 Total : 75.00	
200115	2/16/2016	103029 SAN FERNANDO, CITY OF	16358-16400		REIMBURSEMENT TO WORKERS COM 006-1035	16,236.75 Total : 16,236.75	
200116	2/16/2016	891653 SARGENT TOWN PLANNING	16001	11143	SAN FERNANDO TRANSIT ORIENTED I 113-150-3673-4270	9,476.60 Total : 9,476.60	
200117	2/16/2016	891331 SESAC	ID #386370		ANNUAL MUSIC LICENSE 001-420-0000-4260	378.00 Total : 378.00	
200118	2/16/2016	891064 SIEMENS INDUSTRY INC	5620008876		SPARE CONFLICT MONITOR TESTED E 001-371-0301-4300	247.50 Total : 247.50	
200119	2/16/2016	103184 SMART & FINAL	141524 170064 179625		REFRESHMENTS FOR COMMUNITY ME 017-420-1396-4300 ASCEP SUPPLIES 103-420-0000-4300 104-420-0000-4300 AIR FRESHENERS FOR GYM BATHROC 001-422-0000-4300 115-422-3750-4300	96.90 31.99 31.99 5.48 74.35	
						Page: 18	

vchlist		Voucher List				Page:	19
02/10/2016 4:51:46PM		CITY OF SAN FERNANDO					
Bank code : bank3							
Voucher	Date	Vendor	Invoice	PO #	Description/Account	Amount	
200119	2/16/2016	103184 103184 SMART & FINAL	(Continued)				Total : 240.71
200120	2/16/2016	103218 SOLIS, MARGARITA	48-61		PETTY CASH REIMB		
					001-106-0000-4270	22.00	
					001-106-0000-4300	32.69	
					001-115-0000-4360	80.00	
					001-130-0000-4370	40.00	
					001-222-0000-4300	58.89	
					001-310-0000-4390	12.00	
					001-370-0000-4360	8.11	
					043-390-0000-4360	8.23	
					070-381-0000-4360	16.10	
					070-381-0000-4370	7.78	
					072-360-0000-4360	6.85	
					Total :	292.65	
200121	2/16/2016	103196 SOUTH COAST AIR QUALITY	2905240		PD GENERATOR ANNUAL OPERATING		
			2906118		041-320-0000-4450	346.54	
					FLAT FEE FOR LAST FY EMISSIONS - F		
					041-320-0000-4450	121.44	
					Total :	467.98	
200122	2/16/2016	103202 SOUTHERN CALIFORNIA EDISON CO.	2-02-682-7675		ELECTRIC - FACILITIES (DEC 2015)		
					043-390-0000-4210	3,431.16	
					Total :	3,431.16	
200123	2/16/2016	889149 STAPLES BUSINESS ADVANTAGE	8037446320		WHITE BOARD		
					001-150-0000-4300	251.83	
					Total :	251.83	
200124	2/16/2016	103090 SUSAN SAXE-CLIFFORD, PH.D.	16-0120-3		PROFESSIONAL SERVICES		
					001-222-0000-4260	600.00	
					Total :	600.00	
200125	2/16/2016	892041 SUSTEEN, INC.	9840238	11284	CELL PHONE SOFTWARE FOR DET DIV		
					021-222-0000-4500	4,999.00	
					Total :	4,999.00	

vchlist		Voucher List				Page:	20
02/10/2016 4:51:46PM		CITY OF SAN FERNANDO					
Bank code : bank3							
Voucher	Date	Vendor	Invoice	PO #	Description/Account	Amount	
200126	2/16/2016	101528 THE HOME DEPOT CRC, ACCT#603532202490	1060307		MAT'L'S TO REPLACE CITY HALL STOV		
			1060308		043-390-0000-4300	39.68	
			1685430		SMALL TOOLS FOR MAINT		
			1704159		043-390-0000-4340	45.39	
			2572904		SAFETY VEST FOR PUMPER		
			2572905		070-384-0000-4310	81.16	
			3072617		REPLACEMENT OF STOLEN MAG 3D LI		
			4084681		070-384-0000-4340	32.68	
			4084682		CLAMP METER		
			4974917		043-390-0000-4340	65.67	
			5972669		MAT'LS FOR FINANCE DOOR VIEWER I		
			6881779		043-390-0000-4300	12.01	
			8032950		EPOXY		
			8032951		001-370-0301-4300	88.09	
			8750397		REC PARK GYM LIGHTS & SMALL TOOI		
			9021058		043-390-0000-4300	321.13	
			9064482		LIGHT BULBS FOR ALL FACILITIES		
			9272700		043-390-0000-4300	149.14	
					WELL 2A SALT		
					070-384-0301-4300	886.47	
					SALT FOR WELL 2A (2) & WELL 4A		
					070-384-0301-4300	1,374.34	
					SAFETY VESTS		
					070-383-0000-4310	49.88	
					MALL ELECTRIC TAPE, JUMBO HOOK,		
					001-311-0000-4300	39.33	
					SILICONE & PVC CEMENT		
					029-335-0000-4320	5.23	
					070-384-0000-4300	9.19	
					LOW NOISE GAS BLOWER		
					043-390-0000-4340	216.91	
					MALL TRASH BAGS, DUST PAN & BRO		
					001-311-0000-4300	157.47	
					TRASH CANS REPLACED & CAPS FOR		
					043-390-0000-4300	54.40	
					SNACK BAR SKYLIGHT @ PIONEER PA		
					043-390-0000-4300	55.47	

vchlist		Voucher List				Page:	21
02/10/2016 4:51:46PM		CITY OF SAN FERNANDO					
Bank code : bank3							
Voucher	Date	Vendor	Invoice	PO #	Description/Account	Amount	
200126	2/16/2016	101528	101528 THE HOME DEPOT CRC, ACCT#6035322((Continued)				Total : 3,683.64
200127	2/16/2016	890817	THE WALKING MAN, INC.	E6994	FLYER DISTRIBUTION 017-420-1396-4260	735.00	Total : 735.00
200128	2/16/2016	103903	TIME WARNER CABLE	8448200540010328	CABLE - CITY HALL 02/05/16-03/04/16 001-190-0000-4220	88.38	
				8448200540010518	CABLE - 01/29/16-02/28/16 (REC PARK) 001-420-0000-4260	200.78	
				8448200540222204	CABLE 01/19/16-02/28/16 (PW OPS CEN 043-390-0000-4260	90.54	Total : 379.70
200129	2/16/2016	891311	TORRES, RITA	01/23/16 - 02/05/16	ENP SUBSTITUTE 115-422-3750-4270 115-422-3752-4270	130.00 10.00	Total : 140.00
200130	2/16/2016	887568	TRANS TECH	011407	REPLACE TRANS TEMP SENSOR & SE' 041-320-0228-4400	428.05	Total : 428.05
200131	2/16/2016	890998	TRUJILLO, RODOLFO	FEB 2016	COMMISSIONER'S REIMB 001-310-0000-4111	50.00	Total : 50.00
200132	2/16/2016	103463	U.S. POSTMASTER	DEMAND	PRESORTED FIRST CLASS POSTAGE-I 070-382-0000-4300 072-360-0000-4300	537.88 537.88	Total : 1,075.76
200133	2/16/2016	103444	ULTRA GREENS, INC	56677	MACLAY PLANTS 011-311-7510-4300	28.32	Total : 28.32
200134	2/16/2016	103445	UNDERGROUND SERVICE ALERT	120160671	(28) NEW USA DIG ALERT TICKETS 070-384-0000-4260	42.00	
							Page: 21

vchlist		Voucher List				Page:	22
02/10/2016 4:51:46PM		CITY OF SAN FERNANDO					
Bank code : bank3							
Voucher	Date	Vendor	Invoice	PO #	Description/Account	Amount	
200134	2/16/2016	103445	103445 UNDERGROUND SERVICE ALERT (Continued)				Total : 42.00
200135	2/16/2016	888241	UNITED SITE SERVICES OF CA INC	114-3663490	PORTABLE TOILET RENTAL @ 501 FIRS 043-390-0000-4260	550.04	
				114-3665047	PORTABLE TOILET RENTAL @ LAYNE F 043-390-0000-4260	379.22	Total : 929.26
200136	2/16/2016	103503	UNITED STATES POSTAL SERVICE	15122187	REIMBURSEMENT OF POSTAGE MACH 001-190-0000-4280	1,500.00	Total : 1,500.00
200137	2/16/2016	103449	USA BLUE BOOK	838278	HIGH-VISIBILITY RAINSUITS 070-384-0000-4310	329.79	Total : 329.79
200138	2/16/2016	103510	V & V MANUFACTURING, INC.	41988	POLICE BADGES 001-222-0000-4300 001-222-0000-4300	5,616.85 1,008.60	Total : 6,625.45
200139	2/16/2016	103534	VALLEY LOCKSMITH	3292	REKEY LOCKS & KEY COPIES @ LP PA 043-390-0000-4330	76.65	
				3293	INSTALLATION OF DOOR CLOSER @ L 043-390-0000-4330	150.00	
				3294	KEYS COPIED @ CITY HALL 043-390-0000-4330	30.00	
				3295	KEYS COPIED FOR REC PARK 043-390-0000-4330	45.00	
				3297	REMOTE CONTROLS FOR CITY ELECT 043-390-0000-4300	114.70	Total : 416.35
200140	2/16/2016	891797	VALLEY POWER REPAIRS	2158	SMALL EQUIP - SERVICE GENERATOR 041-320-0311-4400	336.36	
				2159	SMALL EQUIP - REPAIR & SERVICE WA 041-320-0311-4400	265.28	
							Page: 22

vchlist		Voucher List				Page:	23
02/10/2016 4:51:46PM		CITY OF SAN FERNANDO					
Bank code : bank3							
Voucher	Date	Vendor	Invoice	PO #	Description/Account	Amount	
200140	2/16/2016	891797 891797 VALLEY POWER REPAIRS	(Continued)			Total :	601.64
200141	2/16/2016	103550 VANICEK, JAMES	TRAVEL		MANDATORY STC COURSE FOR CRISI 001-225-3688-4360	Total :	135.00 135.00
200142	2/16/2016	101302 VERIZON	8181811075 8183612385 8183616728 8183617825 8183655097 8188372296 8188987385		CITY HALL PAGING 001-190-0000-4220 MTA PHONE LINE 007-440-0441-4220 001-190-0000-4220 ENGINEERING FAX LINE 001-310-0000-4220 HERRITAGE PARK IRRIG SYSTEM 001-420-0000-4220 PD NARCOTICS VAULT 001-222-0000-4220 VARIOUS CITY HALL PHONE LINES 001-190-0000-4220 LP FAX LINE 001-420-0000-4220	Total :	47.53 55.48 26.67 59.08 26.68 303.52 35.64 665.56
200143	2/16/2016	889644 VERIZON BUSINESS	63455057		POLICE LONG DISTANCE 001-222-0000-4220	Total :	87.35 87.35
200144	2/16/2016	892081 VERIZON BUSINESS SERVICES	69672877		MPLS PORT ACCESS & ROUTER - PD V 001-222-0000-4220	Total :	1,036.01 1,036.01
200145	2/16/2016	100101 VERIZON WIRELESS-LA	270693253 561407019		PLANNING CELL PHONES 001-140-0000-4220 CITY YARD CELL PHONE & USB MODEI 070-384-0000-4220 043-390-0000-4220 041-320-0000-4220	Total :	5.40 52.66 27.56 27.56
							Page: 23

vchlist		Voucher List				Page:	24
02/10/2016 4:51:46PM		CITY OF SAN FERNANDO					
Bank code : bank3							
Voucher	Date	Vendor	Invoice	PO #	Description/Account	Amount	
200145	2/16/2016	100101 VERIZON WIRELESS-LA	(Continued)		072-360-0000-4220 001-130-0000-4220 VARIOUS CELL PHONES 001-106-0000-4220 070-384-0000-4220 MDT MODEMS - PD UNITS 001-222-0000-4220 PD CELL PHONES AND MDT MODEMS 001-222-0000-4220 001-152-0000-4220	Total :	0.36 33.21 37.20 83.75 114.06 831.83 114.03 1,327.62
200146	2/16/2016	889681 VILLALPANDO, MARIA	01/23/15 - 02/05/16		FOOD SERVICE WORKER 115-422-3750-4270 115-422-3752-4270	Total :	350.00 50.00 400.00
200147	2/16/2016	103603 VULCAN MATERIALS COMPANY	71007071		COLD MIX 001-311-0000-4300	Total :	1,407.61 1,407.61
200148	2/16/2016	888390 WEST COAST ARBORISTS, INC.	112019	11253	TREE TRIMMING SERVICES 011-311-0000-4260	Total :	715.80 715.80
200149	2/16/2016	888705 WEST COAST TOURS	1200 1204 1206		TRANSPORTAITON-SENIOR CLUB TRIF 004-2384 TRANSPORTATION SERVICES-DEP FO 004-2384 TRANSPORTATION SERVICES-DEP FO 004-2383	Total :	2,450.00 500.00 3,500.00 6,450.00
200150	2/16/2016	890970 WEX BANK	43845060		FUEL FOR CITY FLEET 041-320-0152-4402 041-320-0221-4402	Total :	368.21 254.80
							Page: 24

vchlist Page: 25
 02/10/2016 4:51:46PM Voucher List
 CITY OF SAN FERNANDO

Bank code : bank3

Voucher	Date	Vendor	Invoice	PO #	Description/Account	Amount
200150	2/16/2016	890970 WEX BANK	(Continued)		041-320-0222-4402	103.58
					041-320-0224-4402	448.25
					041-320-0225-4402	3,346.84
					041-320-0226-4402	2.00
					041-320-0228-4402	295.95
					041-320-0311-4402	1,007.75
					041-320-0312-4402	2.00
					041-320-0320-4402	101.84
					041-320-0346-4402	4.00
					041-320-0370-4402	237.37
					041-320-0371-4402	259.25
					041-320-0390-4402	896.20
					041-320-0420-4402	4.00
					007-313-3630-4402	859.77
					027-344-0000-4402	131.59
					029-335-0000-4402	198.89
					070-382-0000-4402	137.75
					070-381-0000-4402	17.13
					070-383-0000-4402	845.77
					070-384-0000-4402	159.01
					072-360-0000-4402	357.04
					Total :	10,038.99
200151	2/16/2016	891531 WILLDAN ENGINEERING	00320839		ST. RESURFACING PRJ. ENGINEERING	
				11285	072-365-0560-4600	7,392.01
				11285	012-311-0560-4600	10,494.99
					Total :	17,887.00
200152	2/16/2016	889491 WILLDAN FINANCIAL SERVICES	010-30023		USER FEE STUDY AND COST ALLOCAT	
				11298	001-190-0000-4270	2,395.00
					Total :	2,395.00
148 Vouchers for bank code : bank3						Bank total :
148 Vouchers in this report						1,021,793.40
						Total vouchers :
						1,021,793.40

Page: 25

vchlist Page: 26
 02/10/2016 4:51:46PM Voucher List
 CITY OF SAN FERNANDO

Bank code : bank3

Voucher	Date	Vendor	Invoice	PO #	Description/Account	Amount
---------	------	--------	---------	------	---------------------	--------

Voucher Registers are not final until approved by Council.

Page: 26

*This Page
Intentionally
Left Blank*

*This Page
Intentionally
Left Blank*



AGENDA REPORT

To: Mayor Joel Fajardo and Councilmembers

From: Brian Saeki, City Manager
By: Chris Marcarello, Deputy City Manager/Public Works Director

Date: February 16, 2016

Subject: Consideration to Install Street Striping and Marking Improvements on Arroyo Avenue Adjacent to Cesar Chavez Learning Academy

RECOMMENDATION:

It is recommended that the City Council:

- a. Approve the Transportation and Safety Commission's recommendation to install traffic and safety striping improvements on Arroyo Avenue, adjacent to Cesar Chavez Learning Academy; and
- b. Approve the striping plans and specifications (Attachment "A").

BACKGROUND:

The Cesar Chavez Learning Academy (school) is located at 1001 Arroyo Avenue. The school is bounded by the San Fernando Swap Meet to the south, the Pacoima Wash to the west, industrial properties to the north, and Arroyo Avenue to the east. Representatives from Los Angeles Unified School District (LAUSD) recently approached the City about reviewing traffic conditions in the vicinity of the school campus. Based on a review by staff and Transportation and Safety Commission, several modifications are recommended to improve traffic safety and parking availability.

Consideration to Install Street Striping and Marking Improvements on Arroyo Avenue Adjacent to Cesar Chavez Learning Academy

Page 2 of 4

School Location



ANALYSIS:

Arroyo Avenue is a sixty-four (64) foot wide collector street with primarily two travel lanes in between Glenoaks Boulevard and Foothill Boulevard. There is a 35 mile per hour speed limit during non-school hours and a 25 mile per hour limit during school hours. There are additional travel lanes to facilitate loading/unloading of students adjacent to the school campus. Field observations confirmed that Arroyo Avenue is busy during school drop-off and pick-up times due to school traffic. Additionally, there are busy adjacent uses including the San Fernando Swap Meet on the south and industrial properties on the north.

After encountering problems with the existing street striping conditions and parking deficiencies, LAUSD approached the City about reviewing and possibly modifying the existing street striping/markings on Arroyo Avenue, from Borden Avenue to Eighth Street. School officials expressed concerns with traffic safety due to high peak travel vehicle volumes, vehicle speeding, existing lane configurations and faded street striping. In addition, school officials indicated that there is a lack of sufficient parking onsite for staff and students.

The Transportation and Safety Commission reviewed this request and took public comment regarding the existing street conditions. Based on the concerns and the preliminary design ideas discussed, the City's traffic engineer finalized traffic striping plans to address safety and mobility concerns. These plans include the following:

Consideration to Install Street Striping and Marking Improvements on Arroyo Avenue Adjacent to Cesar Chavez Learning Academy

Page 3 of 4

- Install New Striping/Markings to Help Improve Lane Visibility
Work will include installing new lane lines and left turn lanes with raised reflective pavement markers as well as repainting crosswalks.
- Paint Lane Tapering to Accommodate On-Street Parking
Work will include the installation of striping to taper travel lanes to match local speed limits, provide additional on-street parking and install left turn lanes. Existing delineators in this vicinity will be replaced with raised pavement markers along the striped traffic lanes. If additional delineators are needed to deter turn movements, they can be re-installed after evaluating the location in spring.
- North of School on Arroyo Avenue – Remove “No Parking” Area and Allow On-Street Parking
Work will include the removal of the existing no parking zone on the west side of Arroyo Avenue, heading north from the school campus. As proposed, approximately 650 feet of on-street parking would be allowed, creating additional parking capacity for approximately thirty (30) vehicles. If approved, No Parking signage would also be removed in this area. Priority would be first-come, first-served and parking restrictions would be the same as allowed for other on-street parking locations on Arroyo Avenue including “No Parking 2 AM – 6 AM”.

Arroyo Avenue – Existing Conditions with No Parking Area



Consideration to Install Street Striping and Marking Improvements on Arroyo Avenue Adjacent to Cesar Chavez Learning AcademyPage 4 of 4

BUDGET IMPACT:

Funds are available in the current Fiscal Year budget for street striping maintenance.

CONCLUSION:

It is recommended that the City Council approve the Transportation and Safety Commission's recommendation and authorize street striping and marking improvements. As proposed, work will be coordinated with LAUSD to take place during spring break recess in March 2016.

ATTACHMENT:

A. Street Striping and Traffic Plans

ATTACHMENT "A"

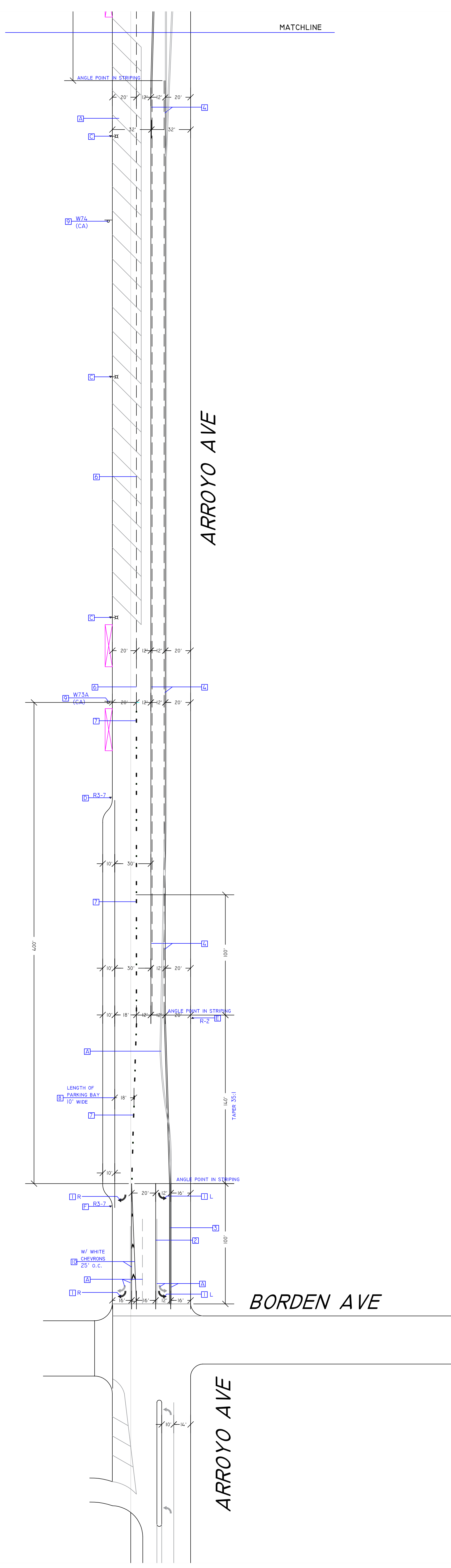

ARROYO AVE

BORDEN AVE

ARROYO AVE

- GENERAL NOTES**
- 1 TRAFFIC SIGNING AND STRIPING SHALL CONFORM TO CALTRANS STANDARD PLANS, CALTRANS TRAFFIC MANUAL AND CALIFORNIA MUTCD, LATEST EDITIONS.
 - 2 ALL PAINT AND PAVEMENT MARKINGS SHALL BE PAINT, TWO COATS.
 - 3 REMOVAL OF EXISTING STRIPING, ARROW, OR LEGEND SHALL BE BY WET SANDBLASTING.

- STRIPING NOTES**
- 1 TYPE IV ARROW
 - 2 DETAIL 38 STRIPING
 - 3 DETAIL 22 STRIPING
 - 4 DETAIL 32 STRIPING
 - 5 10' WIDE 12" WHITE CROSSWALK
 - 6 DETAIL 9 STRIPING
 - 7 DETAIL 37B STRIPING
 - 8 DETAIL 27B STRIPING
 - 9 INSTALL SIGN AND POST AS INDICATED
 - 10 DETAIL 26 STRIPING WITH WHITE CHEVRONS 25' O.C.

- DISPOSITION NOTES**
- 1 REMOVE CONFLICTING STRIPING AND MARKINGS BY WET SANDBLASTING
 - 2 MATCH TO EXISTING
 - 3 REMOVE EXISTING "NO PARKING ANYTIME" SIGNS
 - 4 REMOVE EXISTING SIGN & POLE
 - 5 REMOVE EXISTING SIGN
 - 6 REMAIN IN PLACE

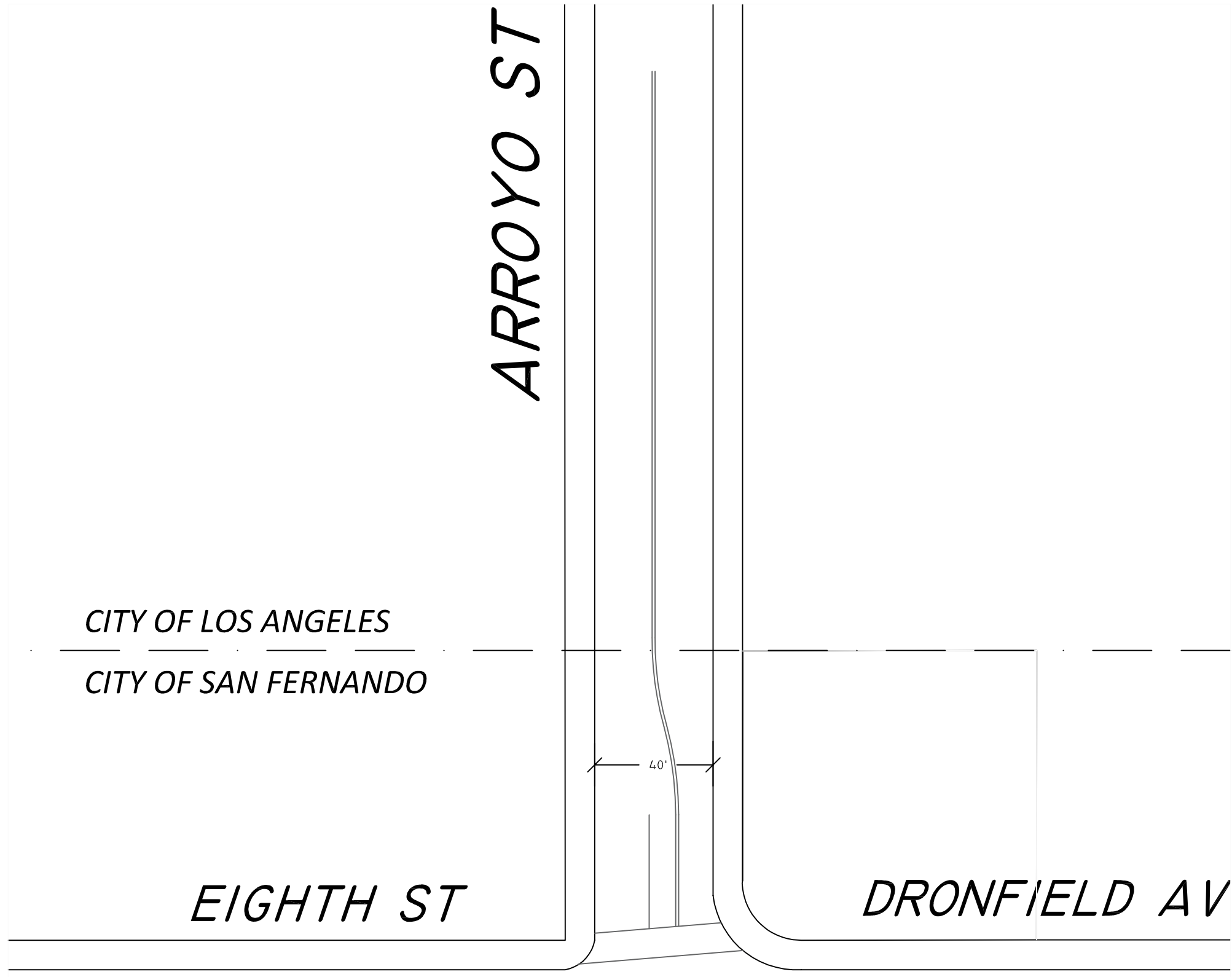
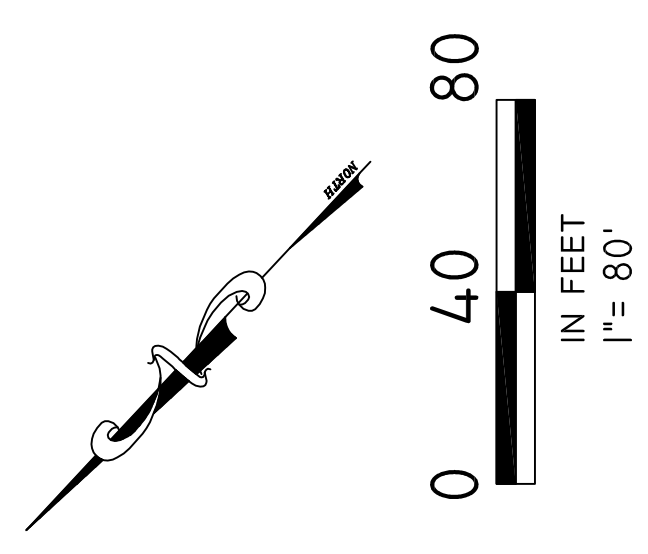

ARROYO ST

CITY OF LOS ANGELES
CITY OF SAN FERNANDO

EIGHTH ST

DRONFIELD AV

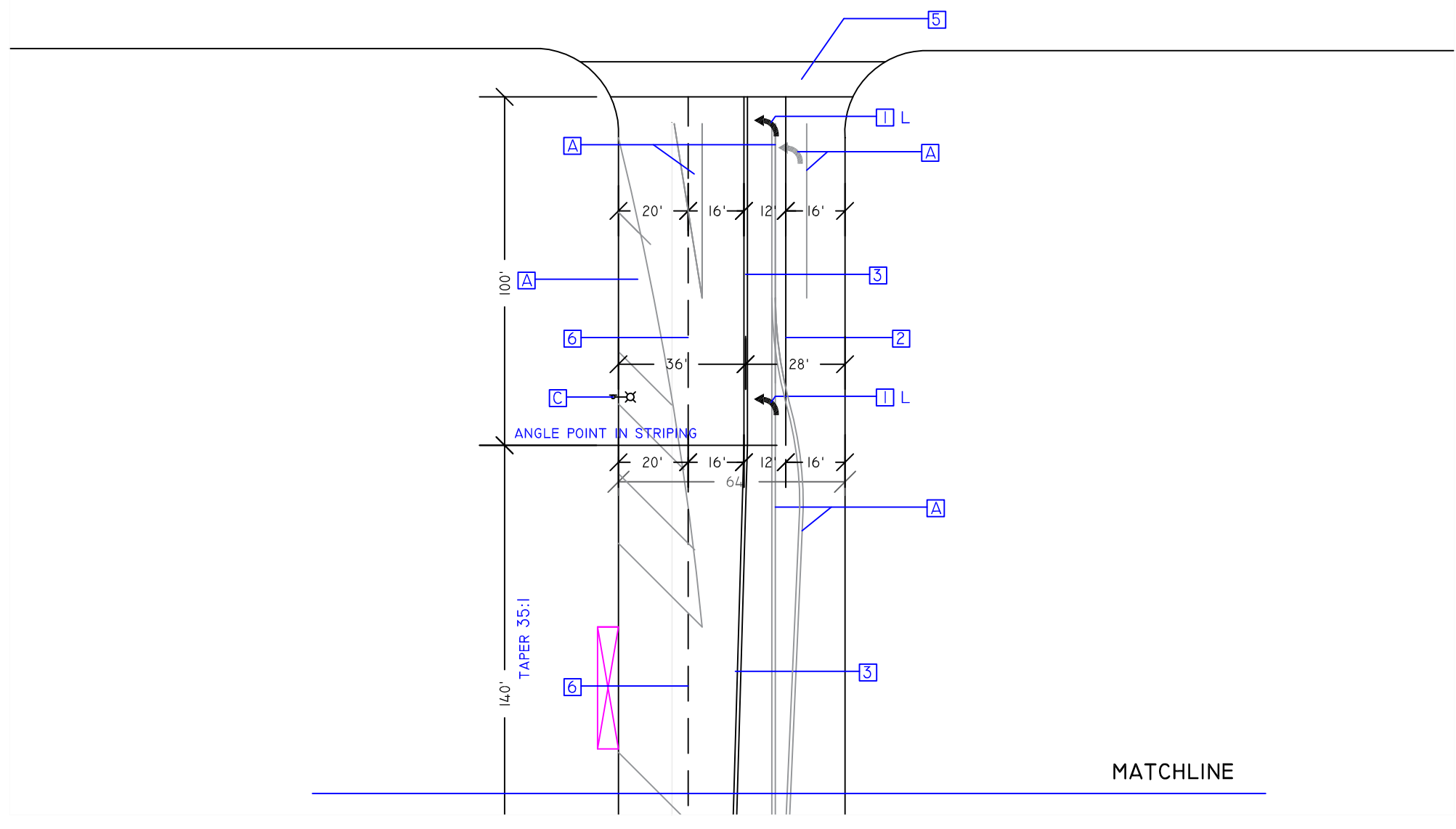

MATCHLINE

<p>SAN FERNANDO HISTORIC & VISIONARY</p>		<p>Arroyo Ave Restriping Plan</p>																															
Mammal Fabian, Civil Engineer/Assistant II DATE: _____		Tom Ibrahim, Traffic Engineer DATE: _____ R.C.E. 724 EXP. DATE: _____																															
<p>REVISIONS</p> <table border="1" style="width: 100%; border-collapse: collapse;"> <thead> <tr> <th style="width: 10%;">DATE</th> <th style="width: 10%;">BY</th> <th style="width: 70%;">DESCRIPTION</th> <th style="width: 10%;">APPROVED</th> </tr> </thead> <tbody> <tr><td> </td><td> </td><td> </td><td> </td></tr> <tr><td> </td><td> </td><td> </td><td> </td></tr> <tr><td> </td><td> </td><td> </td><td> </td></tr> <tr><td> </td><td> </td><td> </td><td> </td></tr> <tr><td> </td><td> </td><td> </td><td> </td></tr> </tbody> </table>		DATE	BY	DESCRIPTION	APPROVED																					<table border="1" style="width: 100%; border-collapse: collapse;"> <tr> <td style="width: 50%; font-size: x-small;">DRAWN BY: MF</td> <td style="width: 50%; font-size: x-small;">TB</td> </tr> <tr> <td style="font-size: x-small;">DESIGNED BY: TB</td> <td style="font-size: x-small;">TB</td> </tr> <tr> <td style="font-size: x-small;">CHECKED BY: TB</td> <td style="font-size: x-small;">TB</td> </tr> </table>		DRAWN BY: MF	TB	DESIGNED BY: TB	TB	CHECKED BY: TB	TB
DATE	BY	DESCRIPTION	APPROVED																														
DRAWN BY: MF	TB																																
DESIGNED BY: TB	TB																																
CHECKED BY: TB	TB																																
<p>UNDERGROUND SERVICE ALERT</p> <p>CALL: TOLL FREE 1-800-422-4133</p> <p>TWO WORKING DAYS BEFORE YOU DIG</p>		<p>UNDERGROUND SERVICE ALERT</p> <p>CALL: TOLL FREE 1-800-422-4133</p> <p>TWO WORKING DAYS BEFORE YOU DIG</p>																															

*This Page
Intentionally
Left Blank*

*This Page
Intentionally
Left Blank*

ORDINANCE NO. 1651**AN ORDINANCE OF THE CITY COUNCIL OF THE CITY OF SAN FERNANDO, CALIFORNIA, AMENDING DIVISION 5 (TEMPORARY USES AND STRUCTURES) OF CHAPTER 106 (ZONING) OF THE SAN FERNANDO CITY CODE TO REGULATE UNATTENDED COLLECTION BOXES**

WHEREAS, the City Council finds that it serves the health, safety, and welfare of the community to maintain a clean and attractive city and protect property values by controlling the presence of containers used to collect charitable donations of clothing and other salvageable items; and

WHEREAS, the City Council finds that a proliferation of such collection boxes without rules and standards harms the community, including potentially creating blight and nuisances; and

WHEREAS, the State Welfare and Institutions Code section 148 et seq. sets forth certain regulations pertaining to Unattended Collection Boxes and the Acquisition and Disposition of Salvageable Personal Property for Charitable Purposes; and

WHEREAS, State Welfare and Institutions Code section 152 authorizes cities to declare any collection box that exists in violation of the law to be a public nuisance subject to abatement; and

WHEREAS, State Welfare and Institutions Code section 153 affirms the power of a city “to impose additional requirements upon the solicitation and sale of salvageable personal property within its jurisdiction”; and

WHEREAS, the City Council desires to address the presence of collection boxes in a manner consistent with State law, and to regulate their use as temporary in nature, with appropriate time limitations; and

WHEREAS, on January 5, 2016, the Planning and Preservation Commission held a properly noticed public hearing at which it received a report from city planning staff as well as oral and written testimony from the public, and deliberated on the item; and

WHEREAS, the City Council public hearing was noticed in accordance with the requirements set forth in Government Code sections 65090 and 65091.

NOW, THEREFORE, THE CITY COUNCIL OF THE CITY OF SAN FERNANDO DOES HEREBY ORDAIN AS FOLLOWS:

SECTION 1. The foregoing recitals are true and correct and made a part of this Ordinance.

SECTION 2. The City Council hereby finds as follows:

a) The proposed zone text amendment is consistent with the objectives, policies, general land uses and programs of the city's general plan.

The proposed amendment regulates collection boxes as accessory uses, and therefore does not restrict or otherwise affect the principal uses contemplated by the City of San Fernando General Plan.

Establishment of zone text language that regulates the review, placement and ongoing operation of unattended collection boxes within the City of San Fernando will help to ensure compatibility with commercial land uses within the City's commercial corridors and is consistent with the City of San Fernando General Plan Land Use Element Goals, which seek to "retain the small town character of San Fernando", promote the economic viability of commercial areas", and "maintain an identity that is distinct from surrounding communities" while also meeting the City General Plan Land Use Element Objective that seeks to attract new commercial activities, particularly in the downtown area". (Source: City General Plan Land Use Element Goals and Objectives; Page IV-6.)

b) The adoption of the proposed zone text amendment would not be detrimental to the public interest, health, safety, convenience or welfare.

The proposed amendment authorizes no change to the environment and thus will add nothing potentially detrimental to the public interest, health, safety, convenience or welfare. Moreover, the city finds that the amendment will protect property values and prevent blight and nuisances caused by the presence of unregulated containers used to collect donations of clothing and other salvageable items, and therefore will enhance and support the public interest, health, safety, convenience and welfare.

SECTION 3. Division 5 (Temporary Uses and Structures) of Article VI (General Regulations) of Chapter 106 (Zoning) of the San Fernando City Code is hereby amended to add the following:

Sec. 106-1113. – Temporary use of unattended collection boxes.

A collection box is permitted as a temporary accessory to a principal permitted use with approval of site plan review by the community development director pursuant to division 3 of article II of this chapter and subject to the following:

- (a) *Definition.* For the purpose of this section, "collection box" means an unattended canister, receptacle, or similar device, used for soliciting and collecting donations of salvageable goods and movable property, but not money or evidences of debt. This term does not include a recyclables container regulated by Chapter 70 of this code.
- (b) *Prohibition.* No person, individual, firm, corporation, partnership, association, club, society, or other entity shall engage in any of the following without a permit in

accordance with this section: (i) place, install, or maintain on any real property a collection box held out to the public for donations; (ii) extract any item from a collection box; or (iii) allow, aid, abet, or suffer any such action.

(c) *Application.*

- (1) Any requirement to show particular information on the site plan may be waived pursuant to section 106-113 as the director deems appropriate.
- (2) The application shall include: (i) the signed and notarized written consent to the application by the owner of the subject parcel of land; (ii) contact information for the person responsible for the ongoing maintenance of the collection box; and (iii) other information deemed appropriate by the director.
- (3) A permit may be issued only to a nonprofit entity that is eligible to solicit donations of salvageable personal property pursuant to Welfare and Institutions Code section 148.3.

(d) *Duration.*

- (1) Written approval of a collection box under this section shall be considered a temporary permit and shall be valid for a period not longer than 24 months as set forth in the permit, unless otherwise provided by this section. The permit shall terminate earlier than the expiration stated therein if: (1) the permit is revoked on the grounds of non-compliance with the permit or other law; or (2) the collection box is abandoned for 30 days after the mailing date of the City's written notification to the permit holder of the abandonment.
- (2) The permit holder and the owner, tenant, and person or entity in control of the parcel of land on which the collection box is placed shall be jointly and severally liable for costs incurred in removing an unpermitted or abandoned collection box. The director may require a cash bond or other guarantee of removal of the temporary use upon expiration of the permit.

(e) *Zones.* Collection boxes are prohibited in the city's residential zones, except on properties with any of the following land uses approved by conditional use permit: churches, temples or other places of religious worship or similar places of assembly, schools, nursery schools, hospitals, sanitariums, large community care facilities, museums, and libraries. This division shall prevail over the restriction against temporary structures at places of religious worship. The director may issue a temporary permit pursuant to this section for a period longer than 24 months if the applicant demonstrates that the collection box is customarily incidental to the principal use in accordance with the City Zoning Ordinance.

(f) *Location.* No collection box shall be placed:

- (1) Within 500 feet of another collection box or a salvage and recycling business, or within 30 feet of the property line of any adjacent residentially zoned parcel. The director shall have discretion to waive or modify these distance restrictions if justified by the following: (i) the collection box is customarily incidental to the principal use; (ii) it will cause no significant adverse effect on adjacent property; and (iii) the public necessity, convenience, general welfare or good zoning practice.
 - (2) Within a yard setback.
 - (3) Within a required off-street parking space.
- (g) *Conditions of approval.* Approvals shall be limited to one collection box per property. The director may impose conditions on a collection box permit to ensure compatibility with surrounding uses and to preserve the public health, safety, and welfare, including, without limitation, aesthetics and periodic review of compliance with this section.
- (h) *Maintenance.* The collection box shall have a firmly closing lid. The permit holder and the parcel owner shall be responsible to:
- (1) Maintain the premises in a clean, sanitary condition at all times, free from discarded items, garbage, and other waste.
 - (2) Regularly empty contents to ensure the collection box does not exceed its capacity.
 - (3) Remove any graffiti or material placed outside of the collection box within 24 hours.
- (i) *Size.* The collection box shall not exceed six cubic yards in volume or six feet in height.

Sec. 106-1114—106-1240. – Reserved.

SECTION 4. Adoption and implementation of this ordinance is exempt from the California Environmental Quality Act (“CEQA”) pursuant to CEQA Guidelines Section 15304 (minor temporary use of land having negligible or no permanent effects on the environment) and categorically exempt under Section 15311 (placement of minor structures accessory to existing commercial, industrial, or institutional facilities).

SECTION 5. Severability. If any section, subsection, sentence, clause, or phrase of this Ordinance is for any reason held to be invalid or unconstitutional by a decision of any court of competent jurisdiction, such decision shall not affect the validity of the remaining portions of this Ordinance. The City Council declares that it would have passed this Ordinance and each and every section, subsection, sentence, clause or phrase not declared invalid or unconstitutional without regard to whether any portion of the Ordinance would be subsequently declared invalid or unconstitutional.

SECTION 6. Effective Date. In accordance with Government Code section 36937, this ordinance shall take effect and be in force 30 days after passage and adoption.

SECTION 7. Certification. The City Clerk is hereby authorized and directed to certify to the passage of this Ordinance by the City Council and shall cause it to be published or posted as required by law.

PASSED, APPROVED, AND ADOPTED by the City Council of the City of San Fernando at its regular meeting on this 16th day of February, 2016.

Joel Fajardo, Mayor

ATTEST:

Elena G. Chávez, City Clerk

APPROVED AS TO FORM:

Rick R. Olivarez, City Attorney

STATE OF CALIFORNIA)
COUNTY OF LOS ANGELES) ss
CITY OF SAN FERNANDO)

I, Elena G. Chavez, City Clerk of the City of San Fernando, do hereby certify that the above and foregoing Ordinance No. 1651 was introduced at the regular meeting of the City Council held on the 16th day of February, 2016, and thereafter at the regular meeting of said City Council, duly held on the 16th day of February, 2016, was passed and adopted by the following votes to wit:

AYES:

NOES:

ABSTAIN:

ABSENT:

Elena G. Chávez, City Clerk

*This Page
Intentionally
Left Blank*



AGENDA REPORT

To: Mayor Joel Fajardo and Councilmembers

From: Brian Saeki, City Manager
By: Ismael Aguila, Recreation and Community Services Director

Date: February 16, 2016

Subject: Consideration to Authorize Submittal of an Application to the California Department of Housing and Community Development Housing Related Parks Program Grant to Fund Layne Park Improvements

RECOMMENDATION:

It is recommended that the City Council:

- a. Adopt Resolution No. 7725 (Attachment "A") authorizing the City's submittal of a grant application to the California Department of Housing and Community Development Housing Related Parks Program in the amount of \$193,950 to provide funds for park improvements at Layne Park;
- b. Authorize the City Manager to accept the grant, if awarded;
- c. Authorize the City Manager to execute all related grant documents required for receiving such grant funds pursuant to the terms and conditions of the grant; and
- d. Upon full execution of all grant related documents, authorize the appropriate revenue and expenditure budget amendments as outlined in the Fiscal Impact section of this report.

BACKGROUND:

1. In 2014, the City of San Fernando was awarded \$188,050 in Housing Related Parks (HRP) Program grant funds that were subsequently used to make physical improvements at San Fernando Recreation Park (208 Park Avenue) that included disabled access, outdoor exercise equipment, and HVAC upgrades.
2. On October 26, 2015, the California Department of Housing and Community Development (HCD) released a Notice of Funding Availability (NOFA) for the 2015 funding round of the Housing-Related Parks (HRP) Program. The HRP grant funds are Proposition 1C funds that

Consideration to Authorize Submittal of Application to the California Department of Housing and Community Development Housing-Related Parks Program to Fund Layne Park ImprovementsPage 2 of 4

can be used to fund park-related capital asset projects. HCD also notified all prospective applicants that the HRP Program applications were due on February 4, 2016.

3. On January 11, 2016, City staff contacted California Consulting, LLC (a consultant firm that has previously assisted the City in successful grant applications) in regards to the possibility of submitting an application to the NOFA for the HRP Program.
4. On January 18, 2016, City staff identified projects at Layne Park (120 North Huntington Street) to be prioritized for rehabilitation.
5. On February 4, 2016, California Consulting, LLC, submitted a Grant Application to the NOFA for the HRP Program. In follow up to the application submittal, the City Council must adopt the attached Resolution No. 7725 (Attachment "A") authorizing the City's submittal of the HRP grant application.

ANALYSIS:**Housing Related Parks (HRP) Program**

The HRP Program is administered by the California Department of Housing and Community Development. The purpose of the HRP Program is to increase the overall supply of housing affordable to lower income households by providing financial incentives to cities and counties with documented housing starts for newly constructed units affordable to very low or low-income households. The HRP Program provides assistance to cities and counties by offering grants for creation of new parks or rehabilitation or improvements to existing parks. Eligible public entities must, by the date set forth in the applicable NOFA, have adopted housing elements that HCD has found to be in substantial compliance with State Housing Element Law, and have submitted to HCD the annual progress reports required by Section 65400 of the Government Code.

Grant amounts are based on the numbers of bedrooms in newly constructed rental and ownership units restricted for very low and low-income households for which building permits have been issued during the designated program year covered by the Notice of Funding Availability. In this particular instance, the NOFA eligible period is for qualifying low income units issued City building permits between January 1, 2010 through December 31, 2015.

Units substantially rehabilitated, converted from market rate to affordable, and preserved with certificates of occupancy issued during the designated program year are also eligible to receive funding, provided they meet the requirements of paragraph (2) of subdivision (c) of Section 65583.1 of the Government Code.

Consideration to Authorize Submittal of Application to the California Department of Housing and Community Development Housing-Related Parks Program to Fund Layne Park Improvements

Page 3 of 4

Qualifying rental units must be rent-restricted for at least 55 years. Ownership units must be initially sold to qualifying households at an affordable cost. Any public funds used to achieve affordability in ownership units must be recovered on resale and reused for affordable housing for at least 20 years. Grants for very low income units will be greater than grants for low-income units.

Notice of Funding Availability

As previously noted in this report, the Notice of Funding Availability (NOFA) for the 2015 funding round of the Housing-Related Parks (HRP) Program was issued in October 26, 2015. The HRP Program is an innovative program designed to reward local governments that approve housing for lower-income households and are in compliance with State Housing Element Law with grant funds to create or rehabilitate parks. A total of \$30 million is available for the 2015 funding round. In 2014, there were 23 cities that were awarded HRP funds, including Anaheim, Chula Vista, Hunting Beach, Glendale, Fresno, and Los Angeles. In addition, the City of San Fernando was the recipient of \$188,550 for park improvements at Recreation Park.

The 2015 NOFA will award HRP Program funds to eligible jurisdictions on a per-bedroom basis for each residential unit affordable to very low- and low-income households permitted during the Designated Program Year (DPY) as defined below. In addition, units substantially rehabilitated, converted from market rate to affordable, and preserved with certificates of occupancy issued during the DPY are also eligible to receive funding provided they meet the requirements of paragraph (2) of subdivision (c) of Section 65583.1 of the Government Code.

The Designated Program Year for the 2015 funding round NOFA includes all eligible units affordable to lower-income households permitted during the designated time period of January 1, 2010 to December 31, 2015 (DPY 2015).

Proposed Project

City staff submitted the grant application for Layne Park because it met all of the NOFA eligibility threshold requirements (Attachment "B"). In addition, the projects listed below were selected based on priorities recommended by City staff.

Project Name: City of San Fernando Layne Park Improvements	
<i>Sub-project</i>	<i>Estimated Costs</i>
Playground Updates	\$100,000
Lighting/Security	\$25,000
Irrigation/Field Improvements	\$38,000
Park Signage	\$7,000
Park Benches	\$5,000
Project Management	\$18,950
Total Project Budget	\$193,950

Consideration to Authorize Submittal of Application to the California Department of Housing and Community Development Housing-Related Parks Program to Fund Layne Park Improvements

Page 4 of 4

BUDGET IMPACT:

The City Council has included pursuing grant funding that provides a net benefit to the City as a goal and priority for Fiscal Year 2015-2016. As such, staff efforts to secure grant funding, as well as an appropriation of \$25,000 for grant writing services, has been included in the Fiscal Year 2015-2016 adopted budget (001-190-0000-4270). If the City is awarded the grant, upon full execution of all grant related documents, the budget will be amended as follows:

SOURCES		
Fund	Account Number	Allocation
California State Grant-Housing Related Parks	118-3697-xxxx	\$ 193,950
Total Sources:		\$ 193,950

USES		
Activity	Account Number	Cost
GRANT: Capital Projects	118-423-0000-4600	\$ 193,950
MATCH: No match required	n/a	\$ 0
Total Uses		\$ 193,950

CONCLUSION:

Approval of this grant will allow for major improvements to Layne Park. It is recommended that the City Council adopt Resolution No. 7725 authorizing the City's submittal of a grant application to the California Department of Housing and Community Development HRP Program in the amount of \$193,950 to provide funds for park improvements. HRP Program funding will provide State grant funds to help improve/repair needed facilities at Layne Park (Attachment "C").

ATTACHMENTS:

- A. Resolution No. 7725
- B. 2015 HRP Application Form
- C. HRP Grant Summary

ATTACHMENT "A"**RESOLUTION NO. 7725****A RESOLUTION OF THE CITY COUNCIL OF THE CITY OF SAN FERNANDO, CALIFORNIA, AUTHORIZING EXECUTION OF STATE STANDARD AGREEMENT FOR HOUSING RELATED PARKS PROGRAM GRANT**

WHEREAS, The State of California, Department of Housing and Community Development (Department) has issued a Notice of Funding Availability dated October 26, 2015 (NOFA), under its Housing-Related Parks (HRP) Program;

WHEREAS, The City of San Fernando desires to apply for a HRP Program grant and submit the 2015 Designated Program Year Application Package released by the Department for the HRP Program;

WHEREAS, The Department is authorized to approve funding allocations for the HRP Program, subject to the terms and conditions of the NOFA, Program Guidelines, Application Package, and Standard Agreement; and

NOW, THEREFORE, THE CITY COUNCIL OF THE CITY OF SAN FERNANDO DOES HEREBY RESOLVE, FIND, DETERMINE, AND ORDER AS FOLLOWS:

SECTION 1. Applicant is hereby authorized and directed to apply for and submit to the Department the HRP Program Application Package released October 26, 2015 for the 2015 Designated Program Year in an amount not to exceed \$193,950.00. If the application is approved, the Applicant is hereby authorized and directed to enter into, execute, and deliver a State of California Standard Agreement (Standard Agreement) in an amount not to exceed \$193,950.00, and any and all other documents required or deemed necessary or appropriate to secure the HRP Program Grant from the Department, and all amendments thereto (collectively, the "HRP Grant Documents").

SECTION 2. Applicant shall be subject to the terms and conditions as specified in the Standard Agreement. Funds are to be used for allowable capital asset project expenditures to be identified in Exhibit A of the Standard Agreement. The application in full is incorporated as part of the Standard Agreement. Any and all activities funded, information provided, and timelines represented in the application are enforceable through the Standard Agreement. Applicant hereby agrees to use the funds for eligible capital asset(s) in the manner presented in the application as approved by the Department and in accordance with the NOFA and Program Guidelines and Application Package.

SECTION 3. The City Manager or Designee authorized to execute in the name of Applicant the HRP Program Application Package and the HRP Grant Documents as required by the Department for participation in the HRP Program.

PASSED, APPROVED, AND ADOPTED this 16th day of February, 2016.

Joel Fajardo, Mayor

ATTEST:

Elena G. Chávez, City Clerk

APPROVED AS TO FORM:

Rick R. Olivarez, City Attorney

STATE OF CALIFORNIA)
COUNTY OF LOS ANGELES) SS
CITY OF SAN FERNANDO)

I HEREBY CERTIFY that the foregoing Resolution was approved and adopted at a regular meeting of the City Council held on the 16th day of February, 2016, by the following vote to wit:

AYES:

NOES:

ABSENT:

Elena G. Chávez, City Clerk



ATTACHMENT "B"

Department of Housing and Community Development HOUSING-RELATED PARKS PROGRAM

Grant Application 2015 Designated Program Year NOFA

Applicant Information

Applicant:	City of San Fernando		
Mailing Address:	910 First Street		
City:	San Fernando		
State:	California	Zip Code:	91340
County:	Los Angeles		
Website:	http://www.ci.san-fernando.ca.us/		
Authorized Representative Name:	Brian Saeki		
Authorized Representative Title:	City Manager		
Phone:	818-898-1201	Fax:	818-898-7329
Email:	bsaeki@sfcity.org		
Contact Person Name:	Fred		
Contact Person Title:	Ramirez		
Phone:	818-898-7316	Fax:	818-898-7329
Email:	framirez@sfcity.org		

Applicant Certification

As the official designated by the governing body, I hereby certify that if approved by HCD for funding through the HRP Program, the City of San Fernando assumes the responsibilities specified in the HRP Program Notice of Funding Availability and Program Guidelines and certifies that the information, statements, and attachments contained in this application are, to the best of my knowledge and belief, true and correct.

Signature: _____ Name: Brian Saeki

Date: _____ Title: City Manager

Updated 10/16/15



Housing-Related Parks Program



Program Guidelines - 2015 Designated Program Year



Housing-Related Parks Program **Program Guidelines** Revised November 2015

Section 100 **Introduction and Program Background**

The Department of Housing and Community Development (Department) is pleased to release revised program guidelines (Guidelines) for funding through the Housing-Related Parks (HRP) Program (Program). The HRP Program is designed to encourage cities and counties to develop new residential housing by rewarding those jurisdictions that approve housing affordable to lower-income households and are in compliance with State housing element law.

The HRP Program was funded through Proposition 1C, the Housing and Emergency Shelter Trust Fund Act of 2006, Health and Safety Code Section 53545, subdivision (d) and originally established pursuant to Chapter 641, Statutes of 2008 (AB 2494, Caballero), at Chapter 8 of Part 2 of Division 31 of the Health and Safety Code (commencing with Section 50700) and subsequently amended pursuant to Chapter 779, Statutes 2012 (AB 1672, Torres). The Program awards funds on a per-bedroom basis for each residential unit affordable to very low- and low-income households permitted during the designated Program year. The Program provides funds for parks and recreation projects that benefit the community and add to the quality of life.

The Department reserves the right, at its sole discretion, to suspend or amend the provisions of these Guidelines, including, but not limited to, grant award amounts.

Section 101 Definitions

Capitalized terms used in these Guidelines shall have the meanings set forth below:

- A. “Building Permit” means a permit issued by a city or a county to construct any building or structure regulated by the Uniform Building Code.
- B. “Converted” means multifamily rental units converted from market rate to affordable by acquisition of the units or purchase of affordability covenants and restrictions as described in paragraph (2) of subdivision (c) of Section 65583.1 of the Government Code, except that the city, county, or city and county may have committed assistance at any time during the projection period.
- C. “Disadvantaged Community” means an area within a city, county, or city and county that is composed solely of those census tracts designated by the United States Department of Housing and Urban Development as having at least 51 percent of its residents at low- or moderate-income levels, using the most recent decennial United States Census data available.
- D. “Department” means the California Department of Housing and Community Development
- E. “Designated Program Year” means the designated time period as indicated in the Notice of Funding Availability (“NOFA”) issued by the Department for each funding round.
- F. “Eligible Subcontractor” means a recreation and park district formed under Chapter 4 (commencing with Section 5780 of Division 5 of the Public Resources Code, a district formed pursuant to Section 5500 or 35100 of the Public Resources Code for the creation or improvement of a park or recreational facility, or any nonprofit organization described in Section 501(c)(3) of the Internal Revenue Code (26 U.S.C. Sec 501(c)(3)), that is exempt from taxation and that has among its purposes the conservation of natural or cultural resources.
- G. “Eligible Unit” means a housing unit that qualifies for the base grant award. Only Eligible Units can qualify for the bonus criteria awards.
- H. “Extremely Low-Income Households” has the meaning set forth in Health and Safety Code Section 50106.
- I. “Infill Project” means a residential or mixed-use residential project located within an Urbanized Area on a site that has been previously developed or on a vacant site where at least 75 percent of the perimeter of the site adjoins parcels that are developed with Urban Uses. In calculating this percentage, perimeters bordering navigable bodies of water and improved parks shall not be included. For these purposes, a property is adjoining the side of a project site if the property is separated from the project site only by an improved public right-of-way.

Section 101
Definitions
~continued~

- J. “Low–Income Households” has the meaning set forth for lower-income households in Health and Safety Code Section 50079.5.
- K. “Park and Recreation Facility” means a facility that provides benefits to the community and includes, but is not limited to, places for organized team sports, outdoor recreation, and informal turf play; non-motorized recreational trails; permanent play structures; landscaping; community gardens; places for passive recreation; multipurpose structures designed to meet the special recreational, educational, vocational, and social needs of youth, senior citizens, and other population groups; recreation areas created by the redesign and retrofit of urban freeways; community swim centers; regional recreational trails; and infrastructure and other improvements that support these facilities.
- L. “Parks Deficient Community” means an area within a city, county, or city and county that has less than three acres of usable parkland per 1,000 residents.
- M. “Preserved” means units preserved at affordable housing costs to lower-income households by acquisition of the units or the purchase of affordability covenants and restrictions as described in paragraph (2) of subdivision (c) of Section 65583.1 of the Government Code, except that the city, county, or city and county may have committed assistance at any time during the projection period.
- N. “Program” means the Housing-Related Parks Program implemented by these Guidelines.
- O. “Qualifying Park Project” means that Park and Recreation Facility designated in the Program Application that meets the eligible use criteria for funding through the Program, as set for in Section 108 of these Guidelines.
- P. “Regional Blueprint Plan” means a regional plan that implements statutory requirements intended to foster comprehensive planning as defined in Section 65041.1 of Chapter 2.5 (commencing with Section 65080) of Division 1 of Title 7 and Article 10.6 (commencing with Section 65580) of Chapter 3 of Division 1 of Title 7 of the Government Code.
- Q. “Substantially Rehabilitated” means units at imminent risk of loss to the housing stock which are substantially rehabilitated and therefore represent a net increase in the community’s affordable housing stock as described in paragraph (2) of subdivision (c) of Section 65583.1 of the Government Code, except that the city, county, or city and county may have committed assistance at any time during the projection period.

Section 101
Definitions
~continued~

- R. “Urbanized Area” means an incorporated city or urbanized area or urban cluster as defined by the United States Census Bureau. For unincorporated areas outside of an urban area or urban cluster, the area shall be within a designated urban service area that is designated in the local general plan for urban development and is served by public sewer and water.
- S. “Urban Uses” means any residential, commercial, industrial, transit, transportation passenger facility, or retail use, or any combination of those uses. Urban uses do not include lands used for agricultural uses or parcels in excess of 15,000 square feet in size and containing only one single-family residence.
- T. “Very Low-Income Households” has the meaning set forth in Health and Safety Code Section 50105.

Section 102 Eligibility and Threshold Criteria

The Program does not use a competitive process to award funds; all cities and counties that meet the eligibility requirements outlined below will be funded as provided in these Guidelines.

A. Eligible Applicants

Cities, counties, and cities and counties are eligible to apply to the Department for funds for eligible costs and activities under the Program.

B. Threshold Criteria

Applicants must meet all of the following threshold requirements for participation in the Program:

1. **Housing Element Compliance:** The applicant must have a housing element that has been adopted by the jurisdiction's governing body and determined to be in substantial compliance with State housing element law pursuant to Government Code Section 65585 by the deadline specified in the NOFA. The jurisdiction's adopted housing element will be deemed to have met this requirement if the adopted element is submitted to the Department on or prior to the date specified in the NOFA and the Department determines the submitted adopted housing element to be in substantial compliance pursuant to Government Code Section 65585 without further amendment. A jurisdiction's current housing element compliance status can be obtained by referencing the Department's website at <http://www.hcd.ca.gov/hpd/hrpp/> or by contacting the Program representative for your region.

2. **Annual Progress Report on the housing element submitted to the Department:** Government Code Section 65400 requires local governments to submit reports to the Department on the jurisdiction's progress in implementing the housing element. To qualify for the Program funding round, an applicant must submit to the Department the Annual Progress Report (APR) required by Government Code Section 65400 for the Designated Program Year. For the purposes of the Program, required Annual Progress Reports must be submitted by the date established in the NOFA. Charter cities are not exempt from this specific program requirement and must submit an Annual Progress Report to be eligible for the Program.

The reports must cover the prior calendar year(s) that immediately precedes the Calendar Year for which eligible units are being claimed and meet all the requirements for the report set forth in Section 65400. If the Designated Program Year covers more than one calendar or fiscal year, the jurisdiction must submit an Annual Progress Report for each of the reporting years in which the jurisdiction has documented eligible units for the purposes of qualifying for funds.

Section 102
Eligibility and Threshold Criteria
~continued~

Please be advised that the Department will not accept other reports in lieu of the APR. Housing Authority Financial Reports, Redevelopment Reports, and other similar reports will not be accepted as meeting this requirement. If uncertain of the status of the report submittal for a jurisdiction, please contact the Department for more information.

3. Eligible Units must meet the following Census Bureau definition:

“A house, an apartment, a mobile home or trailer, a group of rooms, or a single room that is occupied as separate living quarters, or if vacant is intended for occupancy as separate living quarters. Separate living quarters are those in which the occupants live separately from any other individuals in the building and which have a direct access from the outside of the building or through a common hall.”

4. **Minimum Grant Amount:** To be eligible for funding, an applicant must meet a minimum grant amount of \$75,000, including any bonus awards, based on Eligible Units for the Designated Program Year. If an applicant is unable to meet the minimum threshold amount, it may combine Eligible Units from the Designated Program Year with Eligible Units from one or more subsequent funding rounds and apply once it is able to meet the minimum qualification amount.

If the applicant intends to combine Eligible Units from multiple funding rounds in order to apply in a later funding round, all threshold criteria must be met by the close of each Designated Program Year for the respective funding rounds in which qualifying units are being utilized. However, in order to qualify using this method, an applicant must submit an application once it can meet the minimum \$75,000 threshold requirement.

Section 103

Required Threshold Criteria Documentation

- A. Applicants will be required to submit, at minimum, the following documents to the Department as part of the application:
1. For new affordable units: building permits for Eligible Units or installation approvals for manufactured homes issued during the Designated Program Year.

For units Substantially Rehabilitated, Converted, or Preserved: a certificate of occupancy or other evidence of readiness for occupancy within the Designated Program Year. Documentation must also be included to demonstrate the units meet all requirements of paragraph (2) of subdivision (c) of Section 65583.1 of the Government Code, except that the local government may have committed assistance at any time during the projection period.
 2. Documentation of the affordability deed restrictions or covenants associated with each eligible housing unit, including restriction by income level.
 3. Documentation showing the total number of bedrooms by income level for each eligible housing unit. Documentation of affordability and bedroom counts must contain a project identifier, such as an assessor's parcel number (APN), address or other similar identifier that clearly ties the affordability and bedroom count documentation to the Eligible Unit.
- B. Applicants are encouraged to track Eligible Units as they are issued throughout the year and document the affordability and bedroom counts of those units eligible for the Program.

Section 104 Affordability Requirements

The occupancy of Eligible Units must be for households whose incomes are within the published income limits for Very Low- or Low-Income Households. For the purpose of the Program, the units shall be considered affordable if the rent or housing payment is restricted by a regulatory agreement or deed restriction, and does not exceed amounts allowed by common Federal or State housing assistance programs, as determined by the Department.

A. New Construction Units

1. Rental Units: Eligible rental units must be subject to an affordability covenant or agreement recorded on the property that requires the owner to maintain rents on the restricted units at levels affordable to very low- or low-income households for at least 55 years.

For manufactured housing rental units, affordability is determined by the rental amount for the manufactured housing only and does not include the rental amount for the space where the manufactured housing is located.

Specifically, Eligible Units must include:

- a. Affordable rents for Very Low- and Low-income Households¹, and
- b. Covenants restricting occupancy to eligible households and affordable rents for a minimum of 55 years, which begins with the recording date of the instrument used to ensure repayment, typically a deed restriction.

Please note that if the primary funding source for an affordable unit requires a shorter period of affordability, such as 30 years, the applicant must *further restrict* the Eligible Unit for a minimum of 55 years to be eligible for the Program.

2. Ownership Units: Eligible Units must be initially reserved for sale to a very low- or low-income household and ensure the repayment of the public funds and reuse of those funds for affordable housing for a period of at least 20 years. The 20-year time period for ownership units begins with the recording date of the instrument used to ensure repayment, typically a deed restriction.
 - a. If no public funds are used for an ownership unit affordable to a Very Low- or Low-Income Household, the local jurisdiction may count the unit if it can demonstrate that the unit has been or will be initially sold to an income-eligible household at an affordable housing cost.

¹Affordability in rents can be met with or without a subsidy to the tenant or to the unit; rents may be restricted by project or by unit.

Section 104
Affordability Requirements
~continued~

b. All ownership units must be within the applicable sales price limits for new construction as published by the California Housing Finance Agency (CalHFA). The sales price limits can be obtained on the CalHFA website at <http://www.calhfa.ca.gov/homeownership/limits/index.htm>.

3. In mixed-income developments, only those units that meet the Program income and affordability requirements will qualify for an award. Housing units in a mixed-use commercial development that meet the eligibility requirements may be counted in this Program, as well as second units or units that are converted from non-residential to residential uses.

B. Units Substantially Rehabilitated, Converted, and/or Preserved

Pursuant to paragraph (2) of subdivision (c) of Section 65583.1 of the Government Code, the affordability requirements for each type of project are as follows:

Project Type	Minimum Affordability Term
Substantial Rehabilitation	20 years, or the time period required by any applicable federal or state law or regulation
Conversion (multifamily rental units only)	55 years
Preservation	40 years

Section 105 Base Grant Award

- A. Funds will be awarded on a per-bedroom basis for each documented Eligible Unit. Studio and efficiency units are counted as one-bedroom units.
- B. Awards will be distributed on the following basis:
 - 1. \$500 per bedroom for each unit affordable to Low-Income Households
 - 2. \$750 per bedroom for each unit affordable to Very Low-Income Households
- C. The minimum grant amount of \$75,000, including the calculation of any bonus awards, must be achieved through Eligible Units.

Section 106

Bonus Criteria Awards and Required Supporting Documentation

In addition to the base grant award, substantial bonus funds will be awarded for New Construction and Qualifying Park Projects serving Disadvantaged and/or Park-Deficient Communities.

Additional bonus funds will be awarded for Extremely Low-Income Units, Infill Projects, Infill-Supporting Park and Recreation Facility Projects or Regional Blueprint Conformance, and RHNA Bonus.

Eligibility criteria for each of the bonus awards are as follows:

- A. New Construction: A \$300 bonus will be awarded per bedroom for qualifying new housing units based on building permits submitted with the application.
- B. Extremely Low-Income Units: A \$250 bonus will be awarded per bedroom for each unit to be occupied by and affordable to Extremely Low-Income Households.
 1. The application must include documentation of the affordability deed restrictions or covenants associated with the specific number of units and clearly identify that the units are restricted at the Extremely Low-Income level.
- C. Infill Projects: A \$250 bonus will be awarded per bedroom for each Eligible Unit that is built in an Infill Project.
 1. Infill units must be part of a Infill Project located within an Urbanized Area as determined by ONE of the following:
 - a. located within an incorporated city, *OR*
 - b. located within an urbanized area or urban cluster as defined by the U.S. Census Bureau at <http://www.census.gov/2010census/>, *OR*
 - c. for unincorporated areas outside an urbanized area or urban cluster, the area shall be within a designated urban service area that is designated in the local general plan for urban development and is served by public sewer and water.
 2. The Infill Project must meet ONE of the following requirements:
 - a. the site has been previously developed, *OR*
 - b. at least 75 percent of the perimeter of the site adjoins parcels that are currently developed with Urban Uses (refer to definition of Urban Uses in Section 102), or is separated from parcels that are developed with Urban Uses only by an improved public right-of-way. In calculating this percentage, perimeters bordering navigable bodies of water and improved parks shall not be included.

Section 106
Bonus Criteria Awards and Required Supporting Documentation
~continued~

3. Documentation must be submitted to support units are in an Infill Project meeting the criteria above. Documentation can include, but is not limited to:
 - a. engineer's calculations;
 - b. aerial photos;
 - c. historical Documents (to show previously developed status of the site); and
 - d. other documentation acceptable to the Department that sufficiently identifies the project as meeting the definition of an Infill Project.

Note: if aerial photographs are provided, the image must clearly identify the Infill Project site boundaries. In addition, if not easily identifiable, the application should provide a description of the adjacent uses to demonstrate the uses meet the definition of "Urban Uses." If no description is provided, the Department will make a determination to the best of its ability.

- D. Disadvantaged Community: A \$500 bonus will be awarded per bedroom for each Eligible Unit if the applicant can evidence that all Program funds will be spent to create or rehabilitate a park or community recreational facility that will serve a Disadvantaged Community.

1. The applicant must demonstrate that all the Program funds will be utilized for a Qualifying Park Project that meets the definition of a Disadvantaged Community demonstrated through at least ONE of the following:
 - a. Any portion of the Qualifying Park Project is located within or bordered by at least one qualified census tract (QCT) as determined the by U.S. Department of Housing and Urban Development. Documentation to support this identification will be obtained by all applicants through the HUD-User GIS Service QCT Locator available at <http://www.huduser.gov/qct/qctmap.html>
 - OR*
 - b. The Qualifying Park Project is located within a census tract determined by the U.S. Department of Housing and Urban Development having at least 51 percent of its residents at low- or moderate-income levels. Documentation to support this identification will be obtained by all applicants from the dataset available at https://www.hudexchange.info/onecpd/assets/File/ACS_2006_lowmod_blockgroup_ca_2015.xlsx

Section 106
Bonus Criteria Awards and Required Supporting Documentation
~continued~

- E. Park-Deficient Community: A \$500 bonus will be awarded per bedroom for each Eligible Unit if the applicant can demonstrate all Program funds will be utilized for a Qualifying Park Project located in an area within the jurisdiction that qualifies as a Park-Deficient Community.
1. For the purposes of this section, the area within the jurisdiction that must qualify as a Park-Deficient Community will be that which is within a half mile radius of any point within the Qualifying Park Project.
 2. The ratio of useable park space (in acres) per 1,000 residents within a half mile radius of the identified Qualifying Park Project site must be less than three.
 3. Documentation to support this identification will be obtained by all applicants from <http://www.parkinfo.org/factfinder2011/grantee.html>.
- F. Infill-Supporting Park and Recreation Facility or Regional Blueprint Conformance: A \$100 bonus will be awarded per bedroom for each Eligible Unit if the applicant can demonstrate all Program funds will be utilized for a Qualifying Park Project located in an area within the jurisdiction that qualifies as infill-supportive with either (1) or (2) below:
1. Grant funds will be spent to create or improve a Park and Recreational Facility that supports at least one current or previously developed Infill Project. Support of an Infill Project can be evidenced by meeting at least one of the following criteria:
 - a. The Park and Recreational Facility to be created or improved is accessible within a quarter mile radius from a current or previously developed Infill Project, OR
 - b. The Park and Recreational Facility to be created or improved is accessible within a half mile walkable route from a current or previously developed Infill Project. For the purposes of this section, a “walkable route” is a route which after completion of the Qualifying Park Project shall be free of negative environmental conditions that deter pedestrian circulation.

OR

Section 106
Bonus Criteria Awards and Required Supporting Documentation
~continued~

2. The jurisdiction shall provide documentation that it has conformed applicable sections of its adopted General Plan, including the land-use and open space elements in particular, to the land-use provisions of the applicable adopted Regional Blueprint Plan, as may be verified by the Department. This documentation shall include all of the following, in a manner specific to the grant application for the proposed park improvements:
 - a. copies of relevant text, diagrams, or maps from both the General Plan and the Regional Blueprint Plan;
 - b. a resolution from the elected body of the applicant jurisdiction describing the basis of the conformity between the two plans; and
 - c. a letter or resolution from the Council of Governments (COG) having jurisdiction over the Regional Blueprint Plan attesting to the conformity of the General Plan with the adopted Regional Blueprint Plan.

- G. Regional Housing Needs Allocation (RHNA): A \$50 bonus will be awarded per bedroom in units restricted to Low-Income Households and \$75 bonus per bedroom in units restricted to Very Low- or Extremely Low-Income households for jurisdictions that have made significant progress in permitting the housing needed to meet the overall RHNA for the current planning period for the jurisdiction. To qualify for the RHNA bonus, eligible jurisdictions must have met a target percentage as established by the Department, of their overall RHNA, by the end of the Designated Program Year.

The target percentage will be prorated for the number of years completed in each jurisdiction's respective planning cycle. The applicant must meet the target percentage based on new housing units relative to their total RHNA. The Department will calculate each jurisdiction's eligibility for the RHNA bonus award based on the overall number of building permits issued during the current planning period as a percentage of its total RHNA compared to the overall average of new housing units permitted within that county as a whole. For example, if a jurisdiction has met 70 percent of its total RHNA and the average RHNA production of all jurisdictions within that County including the unincorporated County area is 68 percent, that jurisdiction would be eligible for the RHNA bonus.

The bonus will be applied to all Eligible Units. The Department will calculate a jurisdiction's eligibility for the RHNA bonus after the application has been received.

Section 107 Award Calculation

- A. Based on the number of qualifying units and documented bonus award eligibility, eligible applicants may receive up to:
1. \$2,200 per bedroom in qualifying low-income units
 2. \$2,725 per bedroom in qualifying very low-income units

		Bonus Awards Per Bedroom						
		Unit-Based			Park-Based			Other
Qualifying Unit	Base Award per bedroom	New Construction Units	ELI Units	Infill Units	Disadvantaged Community	Park Deficient Community	Regional Blueprint/ Supporting Infill	RHNA Progress*
Low Income	\$500	\$300	N/A	\$250	\$500	\$500	\$100	\$50
Very-Low Income	\$750	\$300	\$250	\$250	\$500	\$500	\$100	\$75

**to be determined by the Department after application submittal*

- B. There is no maximum award, however, if eligibility for funds exceeds the amount of funding available in any round, the Department may reduce all grants proportionally or, in the event the Program is undersubscribed, roll over unused funds to the next funding round.

Section 108 Eligible Use of Funds

- A. Grant funds shall be used for the costs of Park and Recreation Facility creation, development, or rehabilitation, including, but not limited to, the acquisition of land for the purposes of those activities consistent with the requirements set forth in Section 16727 of the Government Code. Program grant funds may be used for the following types of projects:
1. Costs to construct, rehabilitate, or acquire capital assets, meaning:
 - a. Physical property with an expected useful life of 15 years or more.
 - b. Major maintenance, reconstruction, or demolition for purposes of reconstruction of facilities, and retrofitting work that is ordinarily done no more often than once every 5 to 15 years, or expenditures that continue or enhance the useful life of the capital asset.
 - c. Equipment with an expected useful life of two years or more.
 2. Costs incidental to but directly related to the construction or acquisition of a capital asset are allowable.

PLEASE NOTE: QUALIFYING PARK PROJECTS ARE NOT REQUIRED TO BE TIED TO THE HOUSING UNITS USED TO QUALIFY FOR THE BASE GRANT AWARD.

- B. Program grant funds **may not** be used for administrative costs of persons employed by the grantee, such as grant administration, or for other costs not directly related to the acquisition, rehabilitation or construction of a capital asset.
- C. A jurisdiction that receives funds under this Program may subcontract with an Eligible Subcontractor. The subcontract shall be subject to the approval of the Department and shall provide for compliance with all the requirements of the Program. The subcontract shall not relieve the jurisdiction of its responsibilities under the Program.
- D. Successful Program applicants will enter into a State Standard Agreement (Standard Agreement) for distribution of funds. Program grant funds must be spent within two years of the date of award announcement.
- E. No costs incurred prior to the execution date of the Standard Agreement may be charged to Program funds. After the contract has been executed by the State, eligible expenditures may be incurred and expended for the project(s) subject to the terms and conditions of the Standard Agreement.

Requests for fund disbursements must be for at least 25 percent of the total grant amount awarded.

Section 109

Anticipated Application and Expenditure Timelines

Note: sample timeline based on a 2015 program year

Release NOFA, Program Guidelines and Application	October 2015
Applications Due.....	February 4, 2016
Awards Announced.....	June 2016
Standard Agreements.....	August – September 2016
Requests for Fund Disbursement.....	from August 2016
Final Fund Disbursements *	April 30, 2018
Final Expenditure of Funds**	June 30, 2018
Final Reports***	Within 60 days of End of Standard Agreement

* *Final requests for funds may be in advance of anticipated expenditures. This would be considered an advance payment and must be supported with the "final" invoice based on actual expenditures in order to clear the advance payment of funds to the contractor (to show that everything that was advanced, was in fact spent, or the final invoice which could be for less funds, would be accompanied by a check returning the unused funds to the Department. Any advanced funds not allowed, or used, must be returned to HCD, Cashiering Office within 60 days of End of Standard Agreement*

** *Based on this example, while all Program funds must be requested by April 30, 2018 and expended no later June 30, 2018, the qualifying park project is not required to be completed by that date. The grantee must, however, report on the anticipated completion date of the park project in its final report.*

Attachment A

Enabling Legislation

CHAPTER 8. Housing-Related Parks Program [50700. - 50704.5.]

(Chapter 8 added by Stats. 2008, Ch. 641, Sec. 1.)

50700.

For the purposes of this chapter, the following terms have the following meanings, unless the context clearly requires otherwise:

- (a) "Designated time period" means the time period designated in the Notice of Funding Availability required under subdivision (b) of Section 50702.
- (b) "Disadvantaged community," for the purposes of this program, means an area within a city, county, or city and county that is composed solely of those census tracts designated by the United States Department of Housing and Urban Development as having at least 51 percent of its residents of low- or moderate-income levels, using the most recent United States Department of Census data available at the time of the Notice of Funding Availability.
- (c) "Infill project" means a residential or mixed-use residential project located within an urbanized area on a site that has been previously developed, or on a vacant site where at least 75 percent of the perimeter of the site adjoins parcels that are developed with urban uses. For these purposes, a property is adjoining the side of a project site if the property is separated from the project site only by an improved public right-of-way.
- (d) "Park and recreation facility" means a facility that provides benefits to the community and includes, but is not limited to, places for organized team sports, outdoor recreation, and informal turf play; nonmotorized recreational trails; permanent play structures; landscaping; community gardens; places for passive recreation; multipurpose structures designed to meet the special recreational, educational, vocational, and social needs of youth, senior citizens, and other population groups; recreation areas created by the redesign and retrofit of urban freeways; community swim centers; regional recreational trails; and infrastructure and other improvements that support these facilities.
- (e) "Parks deficient community" means a community that has less than three acres of usable parkland per 1,000 residents.
- (f) "Regional blueprint plan" means a regional plan that implements statutory requirements intended to foster comprehensive planning, as defined in Section 65041.1 of, Chapter 2.5 (commencing with Section 65080) of Division 1 of Title 7 of, and Article 10.6 (commencing with Section 65580) of Chapter 3 of Division 1 of Title 7 of, the Government Code. The regional blueprint plan articulates regional consensus and performance outcomes on a more efficient land use pattern that supports improved mobility and reduces dependency on single-occupant vehicle trips; accommodates an adequate supply of housing for all income levels; reduces impacts on valuable farmland, natural resources, and air quality; includes the reduction of greenhouse gas emissions; increases water and energy conservation and efficiency; and promotes a prosperous economy and safe, healthy, sustainable, and vibrant neighborhoods.

(g) "Urbanized area" means an incorporated city or an urbanized area or urban cluster as defined by the United States Census Bureau. For unincorporated areas outside of an urban area or urban cluster, the area shall be within a designated urban service area that is designated in the local general plan for urban development and is served by public sewer and water.

(h) "Urban use" means any residential, commercial, industrial, public institutional, transit, transportation passenger facility, or retail use, or any combination of those uses.

50701.

There is hereby established in state government the Housing-Related Parks Program, to be administered by the department, using funds allocated, upon appropriation, under subdivision (d) of Section 53545, for the purpose of providing grants for the creation, development, or rehabilitation of park and recreation facilities to cities, counties, and cities and counties based on the issuance of building permits for new housing units, or housing units substantially rehabilitated, acquired, or preserved with committed assistance from the city, county, or city and county, that are affordable to very low or low-income households.

50702.

(a) To the extent that funds are available for this purpose, the department shall determine a base grant amount to be provided under this chapter to any city, county, or city and county that meets all of the following criteria:

(1) On or before the end of the period covered by the Notice of Funding Availability required under subdivision (b), the jurisdiction has adopted a housing element that the department, pursuant to Section 65585 of the Government Code, has found to be in substantial compliance with the requirements of Article 10.6 (commencing with Section 65580) of Chapter 3 of Division 1 of Title 7 of the Government Code, and the jurisdiction submitted to the department the annual progress report required under Section 65400 of the Government Code for the preceding 12-month calendar year.

(2) The jurisdiction can document either of the following:

(A) The issuance of building permits for new housing units that are affordable to very low or low-income households within the designated time period and that meet either of the following criteria:

(i) In the case of rental units, the development is subject to a regulatory agreement recorded against the property that obligates the owner to maintain rents on the restricted units at levels affordable to very low or low-income households for at least 55 years.

(ii) In the case of ownership housing, units in the development are initially sold to households of very low or low income at an affordable housing cost. If public funds are used to achieve an affordable housing cost, then upon the sale of an assisted unit to a very low or low-income household, the public entity shall ensure the repayment of the public funds and reuse of those funds for affordable housing for a period of at least 20 years. The proposed mechanism for restrictions of ownership units shall be consistent with criteria established by the department and specified in the Notice of Funding Availability.

(B) The issuance of a certificate of occupancy or other evidence of readiness for occupancy within the designated time period for units that meet the requirements of paragraph (2) of

subdivision (c) of Section 65583.1 of the Government Code, except that the city, county, or city and county may have committed assistance at any time during the projection period.

(b) For each year that funds are available, the department shall issue a Notice of Funding Availability for building permits issued during the designated time period. The department shall accept applications at the close of the designated period. Grant amounts shall be based on a per-bedroom incentive for each unit restricted for very low and low-income households. For the purposes of this section, single-room occupancies and studio apartments shall be considered one-bedroom units.

(c) If eligibility for funds exceeds the amount of funding available for the program, the department shall reduce all grants proportionally.

50703.

(a) The department shall award bonus funds in addition to the base grant award for applicants that meet the requirements under Section 50702. The department shall determine the amount of the bonus funds to be awarded pursuant to this chapter.

(b) The amount of the bonus funds to be awarded shall be established in the Notice of Funding Availability.

(c) Substantial bonus funds shall be awarded for any of the following:

(1) Jurisdictions that demonstrate that grant funds will be spent to improve a park or community recreational facility that will serve a disadvantaged community, as defined in subdivision (b) of Section 50700.

(2) Jurisdictions that demonstrate that grant funds will be spent to create a new park or community recreational facility that will serve a disadvantaged community, as defined in subdivision (b) of Section 50700.

(3) Jurisdictions that meet the definition of a park deficient community, as defined in subdivision (e) of Section 50700.

(4) Qualifying new housing units.

(d) Additional bonus funds shall be awarded for any of the following:

(1) Qualifying units that are affordable to extremely low income households.

(2) Qualifying units that are developed in infill projects.

(3) Jurisdictions that have met or exceeded housing production thresholds established by the department, in consultation with the Department of Finance.

(4) Those jurisdictions that can demonstrate that grant funds will be spent to create or improve a park or community recreational facility to support infill development, or development within a jurisdiction that has conformed its general plan to the regional blueprint, as determined by the council of governments.

50704.

(a) (1) Except as authorized under paragraph (2), a city, county, or city and county shall not receive a grant unless it qualifies, based on building permits issued during the period designated in the Notice of Funding Availability, for a grant in an amount of seventy-five thousand dollars (\$75,000) or more.

(2) If a city, county, or city and county is not able to meet the minimum qualification amount under paragraph (1), it may delay application, combine the number of building permits issued during the designated period described in paragraph (1) with the number of building permits issued during one or more subsequent Notice of Funding Availability periods, and apply once it is able to meet the minimum qualification amount by using the combined amount of building permits issued.

(b) Grants provided pursuant to this chapter shall be used for the costs of park and recreation facility creation, development, or rehabilitation, including, but not limited to, the acquisition of land for the purposes of those activities, consistent with the requirements set forth in Section 16727 of the Government Code.

(c) Funds awarded pursuant to this chapter shall supplement, not supplant, other available funding.

(d) A city, county, or city and county that receives funds under this chapter may subcontract through a recreation and park district formed under Chapter 4 (commencing with Section 5780) of Division 5 of the Public Resources Code, or a district formed pursuant to Section 5500 or 35100 of the Public Resources Code, for the creation or improvement of a park or recreational facility, or any nonprofit organization described in Section 501(c)(3) of the Internal Revenue Code (26 U.S.C. Sec. 501(c)(3)), that is exempt from taxation under Section 501(a) of that code (26 U.S.C. Sec. 501(a)), and that has among its purposes the conservation of natural or cultural resources.

(Amended by Stats. 2012, Ch. 779, Sec. 5. Effective January 1, 2013.)

**DEPARTMENT OF HOUSING AND COMMUNITY DEVELOPMENT
DIVISION OF HOUSING POLICY DEVELOPMENT**

2020 W. El Camino, Suite 500
P. O. Box 952053
Sacramento, CA 95833
(916) 263-7411 / FAX (916) 263-7453
www.hcd.ca.gov



October 26, 2015

MEMORANDUM FOR: Housing-Related Park Program Stakeholders
Interested Parties

FROM: 
Lisa Bates, Deputy Director
Division of Housing Policy Development

**SUBJECT: NOTICE OF FUNDING AVAILABILITY
HOUSING-RELATED PARKS PROGRAM**

The Department of Housing and Community Development (Department) is pleased to announce the release of a Notice of Funding Availability (NOFA) for the 2015 funding round of the Housing-Related Parks (HRP) Program. The HRP Program is an innovative Program designed to reward local governments that approve housing for lower-income households and are in compliance with State housing element law with grant funds to create or rehabilitate parks and/or recreational facilities. **Approximately \$30 million is available for the 2015 funding round.**

The 2015 NOFA will award Program funds to eligible jurisdictions on a per-bedroom basis for each residential unit affordable to very low- and low-income households permitted during the Designated Program Year (DPY) as defined below. In addition, units substantially rehabilitated, converted from market-rate to affordable (multifamily rental units only), and preserved with certificates of occupancy issued during the DPY are also eligible to receive funding provided they meet the requirements of paragraph (2) of subdivision (c) of Section 65583.1 of the Government Code. Base and bonus fund award amounts per bedroom are set forth in the Program Guidelines, Sections 105 and 106. For detailed information, please see the [Program Guidelines](#).

The DPY 2015 NOFA includes all eligible units affordable to lower-income households permitted, substantially rehabilitated, converted and/or preserved during the designated time period of **January 1, 2010 to December 31, 2015**. Applicants that submitted an application for any prior funding round may apply for additional funding for DPY 2015 if there were additional eligible units that would have qualified but were not included in the previous funding round applications. Applicants, however, are not eligible to receive funding for the same units in more than one round of funding.

HRP Program NOFA - 2015 FUNDING ROUND

Page 2

Please note, the deadline for meeting Program threshold requirements as set forth in Section 102 of the Program Guidelines has been extended as detailed below. Please note, if applying for funds based on eligible units for multiple calendar years, required Annual Progress Reports must be submitted to the Department no later than the application due date, February 4, 2016, as established in this NOFA.

Documentation of Eligible Units	Housing Element Compliance	Annual Progress Report
Building permit/occupancy documentation must fall within the following date range detailed below	Housing element which has been adopted by the jurisdiction's governing body and <u>determined to be in substantial compliance with State housing element law</u> pursuant to Government Code Section 65585	Annual Progress Report submitted by application due date for the corresponding calendar year(s) detailed below
CY 2010	Housing element compliance as of December 31, 2015 ¹	CY 2009
CY 2011		CY 2010
CY 2012		CY 2011
CY 2013		CY 2012
CY 2014		CY 2013
CY 2015		CY 2014

¹ Housing element compliance will be for either the 4th or 5th cycle depending on the jurisdiction's 5th cycle housing element due date. To verify which planning period your jurisdiction is currently in, please see the 5th cycle housing element update schedule on the Department's website at <http://www.hcd.ca.gov/hpd/hrc/plan/he/housing-element-update-schedule.pdf>.

To verify housing element compliance and Annual Progress Report submittal status, please refer to the Department's website at <http://www.hcd.ca.gov/hpd/hrpp/>.

Applications must be submitted using the application materials provided on the Department's website at <http://www.hcd.ca.gov/hpd/hrpp/>.

**** Final Application Filing Date ****
February 4, 2016 (Thursday) by 5:00 p.m.

All applicants must submit one original hard copy application with all required attachments and one electronic copy of the application forms (in Excel format). Applications transmitted by e-mail or by facsimile will not be accepted. Applications must be received by the Department by 5:00 p.m. on the application due date. Post marked applications will not be accepted.

The HRP Program's guidelines, application forms, workshop/webinar details, and related program information will be posted on the Department's website at: <http://www.hcd.ca.gov/hpd/hrpp/>.

HRP Program NOFA - 2015 FUNDING ROUND**Page 3**

If you are interested in receiving updated HRP Program information, including notice of the application release, please register for the HRP Program listserv on the Department's webpage at <http://www.hcd.ca.gov/hcd-subscribe.html>.

If you have any questions, please contact your HRP Program Representative (see below). The Department looks forward to working with you on this program.

Region	Representative	Contact Information
Northern California/Bay Area	Fidel Herrera	916.263.7441 fidel.herrera@hcd.ca.gov
Sacramento/Central Valley/ Central Coast/Eastern Sierra	James Johnson	916.263.7426 james.johnson@hcd.ca.gov
Southern California	Hilda Sousa	916.263.1784 hilda.sousa@hcd.ca.gov
Program Manager		
Jennifer Seeger 916.263-7421 / Jennifer.seeger@hcd.ca.gov		

6

*This Page
Intentionally
Left Blank*



AGENDA REPORT

To: Mayor Joel Fajardo and Councilmembers

From: Brian Saeki, City Manager
By: Ismael Aguila, Recreation and Community Services Director

Date: February 16, 2016

Subject: Update on Countywide Park Needs Assessment

RECOMMENDATION:

It is recommended that the City Council provide staff direction on the final recreation facility projects prior to submission to Los Angeles County Department of Parks and Recreation.

BACKGROUND:

1. In 1992, Proposition A was passed by Los Angeles County voters to provide \$53 million a year for parks, open space, and recreation facilities. This proposition was set to expire in June 2015.
2. In 1996, Los Angeles County voters passed an amended Proposition A that provided \$28 million each year additionally for parks, open space, and recreation facilities. This proposition is set to expire in June 2018.
3. On August 5, 2014, Los Angeles County Board of Supervisors approved a resolution providing for and giving notice of a special tax election (Proposition P) being held in the County of Los Angeles on November 4, 2014 and consolidating the special tax election with other elections to be held on November 4, 2014.
4. On November 4, 2014, voters rejected ballot measure Proposition P that would have continued paying for park maintenance and capital projects throughout Los Angeles County.
5. In Summer 2015, the County of Los Angeles informed the City of San Fernando that they were going to conduct a countywide needs assessment designed to identify the need for parks and recreational programs in both cities and unincorporated areas.
6. On November 16, 2015, the City Council approved Funding Agreement No. 1803 (Attachment "A") with the County of Los Angeles to secure "Engagement Funds" for conducting one community engagement meeting.

Update on Countywide Park Needs Assessment

Page 2 of 5

7. On February 3, 2016, staff conducted a community engagement meeting at Las Palmas Park to create a prioritized list of potential future park projects (Attachment "B").

ANALYSIS:

Proposition A

Every year, more than 70 million people visit parks in Los Angeles County including their neighborhood parks and participate in park-sponsored recreational programs. Millions of children and youth use park facilities for after-school, weekend, and summer programs, and millions of seniors attend programs at nearby senior centers. In the City of San Fernando, it is estimated that approximately 35,000 individuals (equating to over 250,000 visits) living in and around the City utilize a park program, facility, and/or resource every year.

While City, State and Federal funding for parks and recreation has decreased over the past 20 years, Los Angeles County voters approved the Safe Neighborhood Parks Tax Measure in 1992, which generates approximately \$54 million annually for neighborhood and regional parks and recreation. Since 1992, The Regional Park and Open Space District has funded almost 1,500 projects with funds from Measure A and additional funding, including children's play areas, trails, permanently converted land to parks or open space, water quality and water supply enhancement projects, tree planting projects, as well as added restrooms/ refurbishments. In San Fernando, the proposition provided funding for the following projects for an approximate \$1.2 million:

- Kalisher Street Corridor
- Construction of the San Fernando Pool Facility
- Recreation Park Graffiti Prevention Project
- Construction of Las Palmas Park
- Graffiti prevention for the mural at Las Palmas Park
- Refurbishing of baseball fields at Las Palmas Park

Countywide Park Needs Assessment

As Proposition A is scheduled to expire in June 2018, many funding opportunities for municipalities could be disappearing. To prepare for the end of Proposition A, the County of Los Angeles is conducting a Countywide Park Needs Assessment designed to identify the need for parks and recreational programs in both cities and unincorporated areas. The goal of the Countywide Park Needs Assessment is to engage all communities within Los Angeles County in a collaborative process to gather data and input for future decision-making on parks and recreation. The Countywide Park Needs Assessment will increase our understanding of existing park and recreation assets, and help us to determine how to improve, expand, and make them more accessible. Specifically, the final report will determine Study Areas and will identify, prioritize, and outline costs for potential park projects within each Study Area. In addition, the

Update on Countywide Park Needs Assessment

Page 3 of 5

Countywide Park Needs Assessment can be used as a guide for potential development of future funding mechanisms and to leverage Federal and State resources, and guide local funding decisions.

Community Engagement Meeting

As one component of the Countywide Park Needs Assessment, City staff conducted a community engagement meeting at Las Palmas Park to create a prioritized list of potential future park projects to submit in the final Countywide Assessment Report. In preparation for the meeting, City and County staff identified 10 park projects to present to the audience in order to create discussion and provide feedback. The projects were to consist of repairs to existing parks, the addition of amenities to existing parks, and/or the creation of a new park or specialty amenity. The 10 projects proposed at the meeting were repairs and/or addition of amenities to City parks (refer to Table 1.1).

Table 1.1

Ten Proposed Projects by City/County Staff	
Las Palmas Athletic Fields	Installation/repair of athletic facilities, including fields and fencing.
Amphitheater at Recreation Park	Install an amphitheater to host various cultural art performances in the City of San Fernando.
Concession Stands	Update concession stands at Recreation Park, Las Palmas Park, and Pioneer Park.
Park Restroom Facilities	Replace/repair restrooms at all park facilities.
Las Palmas Park Facility	Replace/enhance multipurpose room, front lobby, ADA doors, and gym improvements.
Pioneer Park Playground	Replace playground equipment and flooring.
Rudy Ortega Safety	Increase lighting and install additional cameras.
Recreation Park Fields	Replace/repair athletic fields.
Recreation Park Facility	Improve/expand the indoor facility to help accommodate demand of public use, including gym, multipurpose room, exercise area, and meeting rooms.
Pacoima Wash Natural Park Safety	Installation of security lights and cameras at 8 th Street Park for pedestrian safety and the reduction of vandalism, graffiti, theft and other crimes.

In addition, the meeting consisted of conducting a Potential Project Identification Exercise to identify additional projects to include in the discussion. During the Potential Project Identification Exercise, it was requested by participants to include a proposal for the creation of

Update on Countywide Park Needs Assessment

Page 4 of 5

a new skate park in the City of San Fernando. City staff did explain to participants that the creation of a skate park would be costly and would involve acquisition of new land. In addition, it was conveyed that the City may not have the necessary resources to maintain an additional facility of this scale.

As directed by the Countywide Facilitators Toolkit, City staff were asked to provide blue stickers to each participant and allow them to vote for their top ten projects to submit for the Countywide Assessment Report. After voting was completed, there were 10 projects that made the list, including the skate park (Table 1.2). However, according to the Countywide Facilitators Toolkit, a new park with no acquired land is considered to be three projects (1. Land Acquisition, 2. General Park Infrastructure, and 3. Amenities). In order to make room for the skate park project, the Pacoima Wash Bikeway (Project No. 9) and Athletic Field Improvements at Recreation Park (Project No. 10) will need to be removed from the final list. City staff requests the City Council to provide direction on this matter.

Table 1.2

Final Ten Projects		
1	Amphitheater at Recreation Park (1 project)	Install an amphitheater at Recreation Park to host various cultural art performances in the City of San Fernando.
2	Skate Park* (3 projects)	Propose to create a new skate park (Note: No land has been acquired as of yet for this project).
3	Pacoima Wash Natural Park Safety (1 project)	Installation of security lights and cameras at Pacoima Wash Park for pedestrian safety and the reduction of vandalism, graffiti, theft and other crimes. The park is currently maintained by the MRCA but will be transferred to the City of San Fernando by May, 2017.
4	Pioneer Park Fields (1 project)	Replace/repair athletic facilities, including baseball fields and fencing.
5	Community Plaza* Facility (1 project)	Build a plaza-like area (including a community garden, benches and stage) at Rudy Ortega Park for community gathering for all ages.
6	Park Restroom Facilities (1 project)	Replace/improve/repair restrooms at all park facilities.
7	Pioneer Park Playground (1 project)	Replace playground equipment and flooring at Pioneer Park.
8	Concession Stands (1 project)	Update/improve concession stands at Recreation Park, Las Palmas Park, and Pioneer.
9	Pacoima Wash Bikeway (1 project)*	Add a bikeway at the Pacoima Wash Natural Park.
10	Recreation Park Fields (1 project)	Replace/repair athletic fields.

Update on Countywide Park Needs AssessmentPage 5 of 5

**New projects proposed by participants of the Community Engagement Meeting.*

The final 8 or 10 projects will be submitted to the County to be included in the final County Assessment Report. It should be noted that the City is not obligated to commit to any of the projects listed on Table 1.2. They are only recommendations based on one Community Engagement Meeting.

BUDGET IMPACT:

There will be no budget impact to the Fiscal Year 2015-2016 General Fund. All costs associated with the Community Engagement Meeting were paid through the Engagement Funds provided by the County of Los Angeles.

CONCLUSION:

The Countywide Park Needs Assessment conducted by the County of Los Angeles will increase our understanding of existing park and recreation assets, and help the City of San Fernando to determine how to improve, expand, and make them more accessible. In addition, the results of the assessment can be used as a guide for potential development of future funding mechanisms and to leverage Federal and State resources, and guide local funding decisions. Therefore, it is recommended that the City Council provide staff direction on the final recreation facility projects prior to submission to Los Angeles County Department of Parks and Recreation.

ATTACHMENTS:

- A. County of Los Angeles Funding Agreement
- B. Community Engagement Meeting Results



Community Engagement Plan

A Community Engagement Meeting must be held in each Study Area between December 1, 2015 and February 15, 2016. The meeting can be run by city staff or by a community-based organization of your choice. The meeting facilitator must attend one of three trainings. At the training, facilitators will receive all information needed to hold the meeting. To offset the cost of the Community Engagement Meeting, a \$2,500 stipend is available for each Study Area.

Please answer the questions below and return this form to Rita Robinson
robinson@parks.lacounty.gov by **October 15, 2015**

Please tell us about your community engagement meeting:

Date:

Time:

Location:

Parking provided

Accessible by public transportation

What translation services (if any) will be provided? Languages:

Who will be facilitating your community engagement event(s)?

City Staff

Community-Based Organization. Name of CBO:

Please provide the contact information for the primary facilitator **and** any secondary facilitator (if applicable) that will be attending the mandatory training. You may have a **maximum** of 2 people.

Name:

Name:

Title:

Title:

Address:

Address:

Phone:

Phone:

Email:

Email:

Please rank your preference for a mandatory facilitator training date. Space is limited at each training and spaces will be reserved based on the timely return of this form.

Monday--November 16, 2015	10:00am-12:00pm	Roy Anderson Recreation Center
Tuesday--November 17, 2015	6:30pm-8:30pm	Los Angeles County Arboretum
Saturday--November 21, 2015	10:00am-12:00pm	San Fernando Park

Please describe how you will promote your engagement meeting (select all that apply):

Publicly posted notice

Canvassing

Mailers

Television/Radio

Website

Other

Social Media

Please describe your attendance goal (# of attendees):

Please provide any additional details related to your action plan for engaging the community:

The list of prioritized parks projects generated at the community engagement meeting is due to the County by **February 29, 2016**.

**FUNDING AGREEMENT
FOR COMMUNITY ENGAGEMENT ACTIVITIES RELATED TO
THE COUNTYWIDE PARKS NEEDS ASSESSMENT
CITY OF SAN FERNANDO**

THIS FUNDING AGREEMENT ("Agreement") is made and entered into this day of _____, 2015 by LOS ANGELES COUNTY, body corporate and politic ("County") and CITY OF SAN FERNANDO, a body corporate and politic ("City").

WITNESSETH:

WHEREAS, the County Board of Supervisors adopted a motion dated February 3, 2015 authorizing the Director of the County Department of Parks and Recreation to execute this Agreement with the City to fund costs for community engagement activities ("Community Engagement") related to the countywide parks needs assessment effort upon approval as to form by County Counsel.

WHEREAS, the County is willing to provide the City with funding to assist the City in its efforts to engage the residents of the study area(s) listed on Exhibit A attached hereto (each, a "Study Area") to identify and prioritize park projects within such Study Area (s).

WHEREAS, the City, with funding assistance from County, intends to implement a community engagement plan attached thereto as Exhibit B ("Community Engagement Plan") within the Study Area(s).

WHEREAS, County intends to provide funds to the City in the amount of \$2,500 ("Engagement Funds") per Study Area and pursuant to California Government Code Section 26227 County may fund projects that are necessary to meet the social needs of the County.

NOW, THEREFORE, in consideration of the mutual promises, covenants and conditions set forth herein, the parties hereto agree as follows:

A. Approved Funding and Costs. County hereby grants to the City the Engagement Funds in the amount of \$2,500 (\$2,500 per Study Area) to support the City's Community Engagement.

B. Agreement Term. This Agreement will remain in force until completion of the Community Engagement by the City, or as mutually agreed by the City and the County.

C. Indemnity

1. City agrees to indemnify defend and hold harmless County, its agents, special districts, elected officials, officers and employees, from and against any and all liability, expense, including defense costs and legal fees, and claims for damages of any nature whatsoever, including, but not limited to bodily injury, death, personal injury, or property damage arising from or connected with City's operations or services hereunder, including any workers' compensation suits, Federal Fair Labor Standards Act wage or hour law violations, liability, or expense, arising from or connected with services performed by or on behalf of City by any person pursuant to this Agreement.

2. County agrees to indemnify, defend and hold harmless City, its officers, directors, or employees, from and against any and all liability, expense (including reasonable outside attorney fees) resulting from the willful negligent acts or omissions of County, its agents, officers, or employees in connection with this Agreement.

D. Financial Records

1. The City agrees to use a generally accepted accounting system and to maintain satisfactory financial accounts, documents, and records of this expenditure of Engagement Funds and to make them available to County for auditing and inspection at reasonable times for the purpose of verifying appropriateness and validity of expenditures of Engagement Funds under the terms of this Agreement. The City also agrees to retain such financial accounts, documents, and records for five (5) years following termination of this Agreement.

2. The City, within thirty (30) days of notification from County of its audit findings, may dispute the audit findings in writing to County and provide County with records and/or documentation to support the expenditure claims. County shall review this documentation and make a final determination as to the validity of the expenditures.

E. Notices and Approvals

All notices and approvals shall be directed to and made by the following representatives of the parties:

To the Department: Parks and Recreation
 Attn: Norma E. Garcia, Deputy Director
 Planning & Development Agency
 510 South Vermont Avenue
 Los Angeles, CA 90020

To City: Name: _____
 Address: _____

F. Severability/Effective Date/Governing Law/Counterparts/Nondiscrimination

If any provision of this Agreement, or the application thereof, is held to be invalid, that invalidity shall not affect other provisions or applications of the Agreement that can be given effect without the invalid provision or application, and to this end the provisions of the Agreement are severable. The effective date of this Agreement shall be the date that the Agreement is executed by the Department’s Director. This Agreement will be governed by and construed in accordance with California laws. This Agreement may be executed in counterparts, each of which shall be deemed an original. The City shall not discriminate against any person on the basis of race, color, sex, sexual orientation, age, religious belief, national origin, marital status, physical or mental handicap, medical condition, or place of residence in the use of the Engagement Funds paid to the City pursuant to this Agreement.

G. Independent Status.

This Agreement is not intended and shall not be construed to create the relationship of agent, servant, employee, partnership, joint venture or association as between County and City. City understands and agrees to bear the sole responsibility and liability for furnishing Workers’ Compensation benefits to any person for injuries arising from or connected with services performed on behalf of City pursuant to this Agreement.

H. Compliance with Law

City's completion of the Project shall conform to and abide by all County ordinances and all State and Federal laws and regulations insofar as the same or any of them are applicable; and where permits and/or licenses are required for City's work, the same must be first obtained from the regulatory agency having jurisdiction thereover.

IN WITNESS WHEREOF, the City has executed this Agreement, or caused it to be duly executed by its authorized representative, and the County by order of its Board of Supervisors, has delegated to the Director of Parks and Recreation, or his designee, the authority to execute this Agreement on its behalf on the date and year written below.

CITY

By: _____
Name: _____ Date _____
Title: _____

APPROVED AS TO FORM FOR THE CITY:

By: _____
Name: _____ Date _____
Title: _____

COUNTY OF LOS ANGELES

By: _____
Norma E. Garcia Date _____
Deputy Director

APPROVED AS TO FORM FOR THE COUNTY:

MARY C. WICKHAM
Interim County Counsel

By _____
Claudia Gutierrez, Deputy County Counsel

EXHIBIT A

CITY: SAN FERNANDO

STUDY AREA: 02052 (\$2,500)

EXHIBIT B

Community Engagement Plan

(See attached)

ATTACHMENT "B"

Study Area: City of San Fernando

Prioritized Project Reporting Form

Please provide descriptions for the prioritized park projects selected during your Study Area's community engagement workshop. The details you provide will contribute to cost estimates that will be included with your projects in the final report of the LA Countywide Parks Needs Assessment. Please be as specific as possible by providing all details that may have an impact on cost estimates. Along with this form, please attach copies of all voting forms presented at your engagement workshop.

Please return this form to robinson@parks.lacounty.gov no later than February 29, 2016

1. Project Name: Amphitheatre at Recreation Park

Project Location (address, assessor's parcel number, or nearest intersection):
Recreation Park, 208 Park Avenue, San Fernando, 91340

Project Type (choose one):

- Repairs to Existing Amenities
- Add/Replace Amenities in Existing Park
- Build New Park or Specialty Facility

Brief Description of Project:

Install an amphitheater at Recreation Park to host various cultural art performances in the City of San Fernando.





Study Area: City of San Fernando

Prioritized Project Reporting Form

Please provide descriptions for the prioritized park projects selected during your Study Area's community engagement workshop. The details you provide will contribute to cost estimates that will be included with your projects in the final report of the LA Countywide Parks Needs Assessment. Please be as specific as possible by providing all details that may have an impact on cost estimates. Along with this form, please attach copies of all voting forms presented at your engagement workshop.

Please return this form to rrobinson@parks.lacounty.gov no later than February 29, 2016

2. Project Name: Skate Park

Project Location (address, assessor's parcel number, or nearest intersection):
Unknown/Not yet determined

Project Type (choose one):

- Repairs to Existing Amenities
- Add/Replace Amenities in Existing Park
- Build New Park or Specialty Facility

Brief Description of Project:

Propose to create a new skate park (Note: No land has been acquired as of yet for this project).





Study Area: City of San Fernando

Prioritized Project Reporting Form

Please provide descriptions for the prioritized park projects selected during your Study Area's community engagement workshop. The details you provide will contribute to cost estimates that will be included with your projects in the final report of the LA Countywide Parks Needs Assessment. Please be as specific as possible by providing all details that may have an impact on cost estimates. Along with this form, please attach copies of all voting forms presented at your engagement workshop.

Please return this form to rrobinson@parks.lacounty.gov no later than February 29, 2016

3. Project Name: Pacoima Wash Natural Park Safety

Project Location (address, assessor's parcel number, or nearest intersection):
Pacoima Wash Natural Park, 801 Eighth Street, San Fernando, CA 91340

Project Type (choose one):

- Repairs to Existing Amenities
- Add/Replace Amenities in Existing Park
- Build New Park or Specialty Facility

Brief Description of Project:

Installation of Security lights and cameras at Pacoima Wash Park for pedestrian safety and the reduction of vandalism, graffiti, theft and other crimes. The park is currently maintained by the MRCA but will be transferred to the City of San Fernando by May, 2017





Study Area: City of San Fernando

Prioritized Project Reporting Form

Please provide descriptions for the prioritized park projects selected during your Study Area's community engagement workshop. The details you provide will contribute to cost estimates that will be included with your projects in the final report of the LA Countywide Parks Needs Assessment. Please be as specific as possible by providing all details that may have an impact on cost estimates. Along with this form, please attach copies of all voting forms presented at your engagement workshop.

Please return this form to robinson@parks.lacounty.gov no later than February 29, 2016

4. Project Name: Pioneer Park Fields

Project Location (address, assessor's parcel number, or nearest intersection):
Pioneer Park, 828 Harding Street, San Fernando, 91340

Project Type (choose one):

- Repairs to Existing Amenities
- Add/Replace Amenities in Existing Park
- Build New Park or Specialty Facility

Brief Description of Project:

Replace/repair athletic facilities, including baseball fields and fencing.



LOS ANGELES COUNTYWIDE COMPREHENSIVE
PARK & RECREATION NEEDS ASSESSMENT



Study Area: City of San Fernando

Prioritized Project Reporting Form

Please provide descriptions for the prioritized park projects selected during your Study Area's community engagement workshop. The details you provide will contribute to cost estimates that will be included with your projects in the final report of the LA Countywide Parks Needs Assessment. Please be as specific as possible by providing all details that may have an impact on cost estimates. Along with this form, please attach copies of all voting forms presented at your engagement workshop.

Please return this form to robinson@parks.lacounty.gov no later than February 29, 2016

5. Project Name: Community Plaza Facility

Project Location (address, assessor's parcel number, or nearest intersection):
Rudy Ortega Park, 2025 Fourth Street, San Fernando, 91340

Project Type (choose one):

- Repairs to Existing Amenities
- Add/Replace Amenities in Existing Park
- Build New Park or Specialty Facility

Brief Description of Project:

Build a plaza-like area (including community garden space, benches and stage) at Rudy Ortega Park for community gatherings for all ages.



LOS ANGELES COUNTYWIDE COMPREHENSIVE
PARK & RECREATION NEEDS ASSESSMENT



Study Area: City of San Fernando

Prioritized Project Reporting Form

Please provide descriptions for the prioritized park projects selected during your Study Area's community engagement workshop. The details you provide will contribute to cost estimates that will be included with your projects in the final report of the LA Countywide Parks Needs Assessment. Please be as specific as possible by providing all details that may have an impact on cost estimates. Along with this form, please attach copies of all voting forms presented at your engagement workshop.

Please return this form to robinson@parks.lacounty.gov no later than February 29, 2016

6. Project Name: Park Restroom Facilities

Project Location (address, assessor's parcel number, or nearest intersection):
 Recreation Park, 208 Park Avenue, San Fernando, 91340
 Las Palmas, 505 S. Huntington Street, San Fernando, 91340
 Rudy Ortega Park, 2025 Fourth Street, San Fernando, 91340
 Pioneer Park, 828 Harding Street, San Fernando, 91340

Project Type (choose one):

- Repairs to Existing Amenities
- Add/Replace Amenities in Existing Park
- Build New Park or Specialty Facility

Brief Description of Project:

Replace/improve/repair restrooms at all park facilities.



LOS ANGELES COUNTYWIDE COMPREHENSIVE
 PARK & RECREATION NEEDS ASSESSMENT



Study Area: City of San Fernando

Prioritized Project Reporting Form

Please provide descriptions for the prioritized park projects selected during your Study Area's community engagement workshop. The details you provide will contribute to cost estimates that will be included with your projects in the final report of the LA Countywide Parks Needs Assessment. Please be as specific as possible by providing all details that may have an impact on cost estimates. Along with this form, please attach copies of all voting forms presented at your engagement workshop.

Please return this form to rrobinson@parks.lacounty.gov no later than February 29, 2016

7. Project Name: Pioneer Park Playground

Project Location (address, assessor's parcel number, or nearest intersection):
Pioneer Park, 828 Harding Street, San Fernando, 91340

Project Type (choose one):

- Repairs to Existing Amenities
- Add/Replace Amenities in Existing Park
- Build New Park or Specialty Facility

Brief Description of Project:

Replace playground equipment and flooring at Pioneer Park.



LOS ANGELES COUNTYWIDE COMPREHENSIVE
PARK & RECREATION NEEDS ASSESSMENT



Study Area: City of San Fernando

Prioritized Project Reporting Form

Please provide descriptions for the prioritized park projects selected during your Study Area's community engagement workshop. The details you provide will contribute to cost estimates that will be included with your projects in the final report of the LA Countywide Parks Needs Assessment. Please be as specific as possible by providing all details that may have an impact on cost estimates. Along with this form, please attach copies of all voting forms presented at your engagement workshop.

Please return this form to robinson@parks.lacounty.gov no later than February 29, 2016

8. Project Name: Concession Stands

Project Location (address, assessor's parcel number, or nearest intersection):

Recreation Park, 208 Park Avenue, San Fernando, 91340

Las Palmas, 505 S. Huntington Street, San Fernando, 91340

Pioneer Park, 828 Harding Street, San Fernando, 91340

Project Type (choose one):

- Repairs to Existing Amenities
- Add/Replace Amenities in Existing Park
- Build New Park or Specialty Facility

Brief Description of Project:

Update/improve concession stands at Recreation Park, Las Palmas Park, and Pioneer Park.



LOS ANGELES COUNTYWIDE COMPREHENSIVE
PARK & RECREATION NEEDS ASSESSMENT



Study Area: City of San Fernando

Prioritized Project Reporting Form

Please provide descriptions for the prioritized park projects selected during your Study Area's community engagement workshop. The details you provide will contribute to cost estimates that will be included with your projects in the final report of the LA Countywide Parks Needs Assessment. Please be as specific as possible by providing all details that may have an impact on cost estimates. Along with this form, please attach copies of all voting forms presented at your engagement workshop.

Please return this form to robinson@parks.lacounty.gov no later than February 29, 2016

9. Project Name: Pacoima Wash Bikeway at Pacoima Wash Natural Park

Project Location (address, assessor's parcel number, or nearest intersection):
Pacoima Wash Natural Park, 8th Street, San Fernando, 91340

Project Type (choose one):

- Repairs to Existing Amenities
- Add/Replace Amenities in Existing Park
- Build New Park or Specialty Facility

Brief Description of Project:

Add a bikeway at the Pacoima Wash Natural Park.



LOS ANGELES COUNTYWIDE COMPREHENSIVE
PARK & RECREATION NEEDS ASSESSMENT



Study Area: City of San Fernando

Prioritized Project Reporting Form

Please provide descriptions for the prioritized park projects selected during your Study Area's community engagement workshop. The details you provide will contribute to cost estimates that will be included with your projects in the final report of the LA Countywide Parks Needs Assessment. Please be as specific as possible by providing all details that may have an impact on cost estimates. Along with this form, please attach copies of all voting forms presented at your engagement workshop.

Please return this form to robinson@parks.lacounty.gov no later than February 29, 2016

10. Project Name: Upgrade Athletic Fields at Recreation Park

Project Location (address, assessor's parcel number, or nearest intersection):
Recreation Park, 208 Park Avenue, San Fernando, 91340

Project Type (choose one):

- Repairs to Existing Amenities
- Add/Replace Amenities in Existing Park
- Build New Park or Specialty Facility

Brief Description of Project:

Upgrade baseball/multi-purpose fields at Recreation Park.



LOS ANGELES COUNTYWIDE COMPREHENSIVE
PARK & RECREATION NEEDS ASSESSMENT

*This Page
Intentionally
Left Blank*

*This Page
Intentionally
Left Blank*



AGENDA REPORT

To: Mayor Joel Fajardo and Councilmembers

From: Brian Saeki, City Manager
By: Nick Kimball, Finance Director

Date: February 16, 2016

Subject: Presentation of Fiscal Year 2014-2015 Comprehensive Annual Financial Report

RECOMMENDATION:

It is recommended that the City Council receive and file a presentation of the Fiscal Year 2014-2015 Comprehensive Annual Financial Report.

BACKGROUND:

1. The City Code requires an annual audit to be conducted by independent certified public accountants shortly after the end of each fiscal year. The audit is conducted, and financial statements prepared, in accordance with generally accepted accounting principles (GAAP) as promulgated by the Governmental Accounting Standards Board (GASB).
2. The financial statements were audited by Van Lant & Fankhanel, LLP; a public accounting firm fully licensed and qualified to perform audits of State and local governments within the State of California.
3. The audited financial statements, in conjunction with the accompanying notes, discussion, and analysis, are presented in a Comprehensive Annual Financial Report to provide a thorough and detailed presentation of the City's financial condition at a particular point in time (i.e. the end of the fiscal year).
4. On December 28, 2015, the Comprehensive Annual Financial Report for Fiscal Year ending June 30, 2015 (2015 CAFR) was completed and posted to the City's website for public review.
5. On January 26, 2016, staff gave a presentation of the 2015 CAFR and received feedback from the Budget, Personnel and Finance Standing Committee.
6. The 2015 CAFR has been submitted to the Government Finance Officers Association (GFOA) for consideration of the Certificate of Achievement for Excellence in Financial Reporting

Presentation of Fiscal Year 2014-2015 Comprehensive Annual Financial ReportPage 2 of 4

Award. The award is presented to government agencies whose comprehensive annual financial reports achieve the highest standards in government accounting and financial reporting. With a few exceptions, the City has received this award consistently over the last 26 years.

ANALYSIS:

The CAFR consists of four parts: 1) Management's Discussion and Analysis; 2) the basic financial statements; 3) required supplementary information; and 4) *optional* combining statements for non-major governmental funds.

Within the basic financial statements are three components: 1) Government-wide Financial Statements; 2) Fund Financial Statements; and 3) Notes to the Financial Statements. The Government-wide Financial Statements provide the broadest picture of the City's finances as they include all of the City's thirty funds (including the General Fund and Enterprise Funds). The Fund Financial statements are a subset of the Government-wide Financials as they present each fund's financial statements individually. The Notes to the Financial Statements provide detail explanations.

Both the Government-wide Financials and Fund Financials include two basic statements: 1) *Statement of Net Position*, which presents information in terms of total assets, liabilities and net position (i.e. assets less liabilities); and 2) *Statement of Activities*, which shows how the net position has changed during the most recent fiscal year through revenues (increase in net position) and expenditures (decrease in net position).

Below are some key highlights of the 2015 Audit:

Government-wide Financials. The City's total net position, which includes the General Fund, Enterprise Funds, and all Special Revenue Funds, decreased from \$63,052,833 as of June 30, 2014 to \$33,948,425 as of June 30, 2015; a total decrease of \$29,104,408. Over time, net position may serve as an indicator of the City's financial position.

The dramatic decrease in net position is the result of a new reporting requirement by the Government Accounting Standards Board, Statement No. 68 (GASB 68). GASB 68 requires governments providing defined benefit pensions (e.g. CalPERS) to recognize long-term obligations for pension benefits as a liability, and to more comprehensively and comparably measure the annual costs of pension benefits. As a result of GASB 68, the City's long-term net pension liability increased by \$26,809,903. Additionally, the City's long-term Other Post-Employment Benefit (OPEB) obligation for retiree healthcare increased by \$1,812,248 to \$10,916,264.

Presentation of Fiscal Year 2014-2015 Comprehensive Annual Financial ReportPage 3 of 4

The City's total net position is made up of the following:

1. Capital Assets (e.g. land, buildings, infrastructure, vehicles, etc.) - \$60,591,272
2. Restricted (e.g. transportation, housing, grants) - \$5,887,197
3. Unrestricted – **(\$32,530,044)** **Deficit due to pension and retiree health liabilities.*

General Fund Financials. As of June 30, 2015, the total deficit fund balance for the General Fund decreased from **(\$5,693,905)** to **(\$4,114,045)**. The total deficit reduction from June 30, 2014 to June 30, 2015 was \$1,579,860.

The General Fund fund balance is made up of the following:

1. Restricted for:
 - a. Inventories - \$38,156
 - b. Prepaid items - \$2,787
 - c. Advances to Other Funds - \$329,604
2. Unrestricted - **(\$4,485,592)** **Deficit due to the amount owed to the Retirement Fund.*

Finding 2015-1. The City received one significant Finding (Finding 2015-1) related to the General Fund's continued deficit fund balance. This is the sixth year in a row that the City has received this particular Finding, and we will continue to receive the finding until the deficit is eliminated. The Finding, including Management's response, is included as Attachment "A".

Management encourages readers to read both the Transmittal Letter and Management's Discussion and Analysis to get a better contextual understanding of the financial information presented in the 2015 CAFR.

BUDGET IMPACT:

Funds to prepare the 2015 CAFR were included in the Fiscal Year 2015-2016 Adopted Budget. There is no budget impact to receiving and filing a presentation on the 2015 CAFR.

CONCLUSION:

This year's audited financials present mixed signals. Although the General Fund deficit decreased by \$1.5 million, it continues to have a large deficit fund balance of (\$4.1 million). Also, the total City-wide "net worth" decreased by \$29.1 million due to long-term pension and retiree health obligations. Please note, with regards to the long-term pension and retiree health obligations, the obligation did not increase; there was a new nation-wide governmental reporting requirement that took effect in Fiscal Year 2014-2015 that required the

Presentation of Fiscal Year 2014-2015 Comprehensive Annual Financial ReportPage 4 of 4

City report the obligations on our balance sheet. Like San Fernando, many cities throughout the United States will be experiencing a significant erosion in net position.

ATTACHMENTS:

- A. Finding 2015-1 with Management's Response
- B. PowerPoint Presentation

CITY OF SAN FERNANDO
SCHEDULE OF FINDINGS AND RESPONSES
Year Ended June 30, 2015

2015-1: Deficit Fund Balance

Finding:

The following is a continuation from prior years:

The City's General Fund had a total deficit fund balance of \$4,114,045 as of June 30, 2015. Although the General Fund experienced an increase in fund balance of \$1,579,860 during the 2014-15 fiscal year, approximately \$1 million of this increase was related to a one-time sale of property. In addition, the excess revenues over expenditures in the current year do not take into account the increase in the Other Post-employment Benefits (OPEB) liability which is increasing approximately \$1.8 million each year. As of June 30, 2015, the City has a cumulative OPEB liability of \$10.9 million. This is the amount, based on actuarial calculations, that the City should have contributed to the OPEB plan over the past several years, but has not. Also, retirement benefits costs are increasing significantly each year. Expenditures will continue to increase in the future, because of these issues.

It is essential that governments, including the City, maintain adequate levels of fund balance to mitigate current and future risks (e.g., revenue shortfalls and unanticipated expenditures). Fund balance levels are a crucial consideration in long-term financial planning.

The Government Finance Officers Association (GFOA) has developed a "Best Practice" in this area. They recommend that governments establish a formal policy on the level of unrestricted fund balance that should be maintained in the general fund. As described by GFOA, "the adequacy of unrestricted fund balance in the general fund should be assessed based upon a government's own specific circumstances. Nevertheless, GFOA recommends, at a minimum, that general-purpose governments, regardless of size, maintain unrestricted fund balance in their general fund of no less than two months of regular general fund operating revenues or regular general fund operating expenditures. The choice of revenues or expenditures as a basis of comparison may be dictated by what is more predictable in a government's particular circumstances."

Although the City has taken certain steps to address these issues, we recommend the City continue in its efforts to establish a long-term plan to eliminate fund deficits and interfund borrowings, and create an appropriate level of General Fund reserves for the future. The City should consider referring to GFOA's Best Practice in developing a long-term plan.

CITY OF SAN FERNANDO
SCHEDULE OF FINDINGS AND RESPONSES
Year Ended June 30, 2015

2015-1: Deficit Fund Balance - Continued

Management's Response:

Eliminating the General Fund deficit, addressing the City's long term Other Post Employment Benefits liability, and ensuring long-term sustainability of the City's pension program are top priorities for the City Council and City management. In accordance with GFOA Best Practices, the City Council adopted a Budget Policy and Comprehensive Financial Policy in November 2014 to formalize the City's commitment to long-term financial stability. The Comprehensive Financial Policy includes a target Contingency Fund balance of twenty percent (20%) of the adopted General Fund operating expenditures, which exceeds the minimum recommended by GFOA. Additionally, the City developed a five-year financial forecast for the General Fund that lays out the plan to eliminate the deficit by fiscal year 2019-2020.

General Fund. The City's General Fund has been in a deficit fund balance position since FY 2010-2011. The City has taken a number of steps over the last three years to stabilize ongoing finances, including re-negotiating labor contracts, reducing programs and services, reducing professional development, travel, and memberships by City staff, implementing layoffs and furloughs, and freezing vacant positions. As a result, the General Fund deficit has decreased from (\$5,693,905) as of June 30, 2014 to (\$4,114,045) as of June 30, 2015. However, many of these were short-term fixes that were necessary to remain solvent; continuing these cuts is not sustainable in the long-term. Consequently, staff has worked with City Council to implement a multi-year plan to eliminate the General Fund deficit, which includes a balance of ongoing revenue enhancements and targeted expenditure reductions.

In 2013, the City declared a fiscal emergency and held a special election for a temporary one-half (½) cent transaction and use tax, which was approved by sixty percent (60%) of voters. This transaction tax, also referred to as "Measure A," will sunset in October 2020.

The transaction tax is projected to raise approximately \$2 million per year in general revenue and is necessary to fund a number of critical one-time needs. Since the transaction tax is temporary and will sunset in 2020, it is prudent to use the funds raised through the tax on non-recurring expenditures. Consequently, transaction tax revenue has been earmarked to address the following needs: 1) establish General Fund and Self Insurance Fund reserves, 2) pay off existing debt, 3) re-establish the City's Equipment Replacement Fund, 4) replace and update the City's outdated computer hardware, software, and telecommunications systems, 5) establish a trust to pre-fund Other Post-Employment Benefits (OPEB), and 6) fund overdue capital projects to reduce the City's deferred infrastructure and maintenance costs.

In addition to the revenue raised by Measure A, the City has taken a number of steps in the last eighteen (18) months to address the City's deficit and improve long-term financial stability, including:

CITY OF SAN FERNANDO
SCHEDULE OF FINDINGS AND RESPONSES
Year Ended June 30, 2015

2015-1: Deficit Fund Balance - Continued

- Renegotiated the Fire and Emergency Services contract with the Los Angeles Fire Department to reduce the City's annual cost without reducing service;
- Transferred operational and financial responsibility of the San Fernando Regional Pool to the County of Los Angeles;
- Retired debt from the outstanding California Housing Financing Agency (CHFA) and Section 108 Loans;
- Developed a five-year General Fund projection of revenues and expenditures;
- Adopted a Development Agreement Ordinance to provide additional tools to increase economic development efforts;
- Sold surplus land and used the land sale proceeds to reduce the City's deficit;
- Restructured future retiree health benefits to decrease the City's OPEB liability; and
- Updated the City's long term financial planning policies, including budget, purchasing, debt management, grant management, investment, and reserve policies, with an emphasis on creating long term fiscal sustainability.

To continue implementation of the deficit elimination plan in FY 2015-2016, the Adopted Budget includes the following:

- Funding to complete a user fee and cost allocation plan to ensure the City is adequately recovering costs for certain services;
- Funding to replace the City's network server infrastructure;
- Funding to re-establish a Self-Insurance Fund reserve;
- Funding to re-establish an Equipment Replacement Fund; and
- Funding to partner with a professional services firm to increase resources available to bolster the City's business license program, increase compliance, and collect ongoing revenue due to the City.

Despite the progress that has been made in the past year and the investments being funded in the upcoming fiscal year, the City is still facing a significant General Fund deficit and must continue to implement best financial management practices, protect revenues, and strategically appropriate funds based on sound cost-benefit analysis.

CITY OF SAN FERNANDO
SCHEDULE OF FINDINGS AND RESPONSES
Year Ended June 30, 2015

2015-1: Deficit Fund Balance - Continued

The deficit elimination plan was developed with the understanding that the General Fund deficit is a result of many years of financial problems, some of which have been beyond the City's control (e.g. the "Great Recession" and dissolution of redevelopment) and others that were self-inflicted. It will take many years to dig the City out; however, if the preceding financial and operational elements continue to be implemented, the City will be successful in eliminating the General Fund deficit and building a strong financial base for the future.

Other Post-Employment Benefits (OPEB). In the first quarter of fiscal year 2015-2016, the City completed negotiations with all bargaining units. The City was successful in restructuring retiree medical benefits for employees hired on or after July 1, 2015. As a result, the City will provide the minimum retiree health benefit required by the Public Employees Medical and Health Care Act (PEMHCA), which is \$122 per month for calendar year 2015 and adjusted by CalPERS annually to account for inflation. This will result in a significant long term savings as current employees retire and are replaced by new employees. The City will continue to explore options to fund the Annual Required Contribution in the future.

Retirement Benefits. Despite the rising cost of retiree pensions, the City is uniquely positioned to fully fund these costs going forward. San Fernando is one of a handful of California cities that has a local property tax restricted to pay pension costs, which ultimately limits the exposure of increased pension rates on the City's General Fund. The City may levy a tax, up to 0.28% of assessed property value, to fund the City's pension obligation annually. For fiscal year 2015-2016, the City was able to fully fund the annual pension obligation with a levy of 0.24% of assessed values.

The Retirement Fund, which accounts for the proceeds of the retirement tax levy, has a healthy fund balance of \$5 million to absorb future increases in pension costs without creating an additional burden on local tax payers. The Retirement Fund is expected to remain healthy due to recent legislation (SB 107) clarifying that local retirement tax levies that were being previously being remit to former redevelopment agencies shall be remit to local cities provided they are not required to pay debt service on existing debt. This will further bolster the fund balance in the Retirement Fund and allow the City to further reduce the long-term pension liability.

Despite the ability to levy a retirement tax, the City recognized the need to curb long-term pension costs and create a sustainable long term benefit. Consequently, the City reduced pension benefits for new employees in 2005. Moreover, the California Legislature passed the Public Employees' Pension Reform Act (PEPRA), which took effect in 2013 and further reduced pension benefits for new City employees. All of these actions will ultimately reduce the City's long term pension costs and limit the General Fund's exposure to costs that exceed the maximum tax levy as legacy employees are replaced with new employees.

ATTACHMENT B

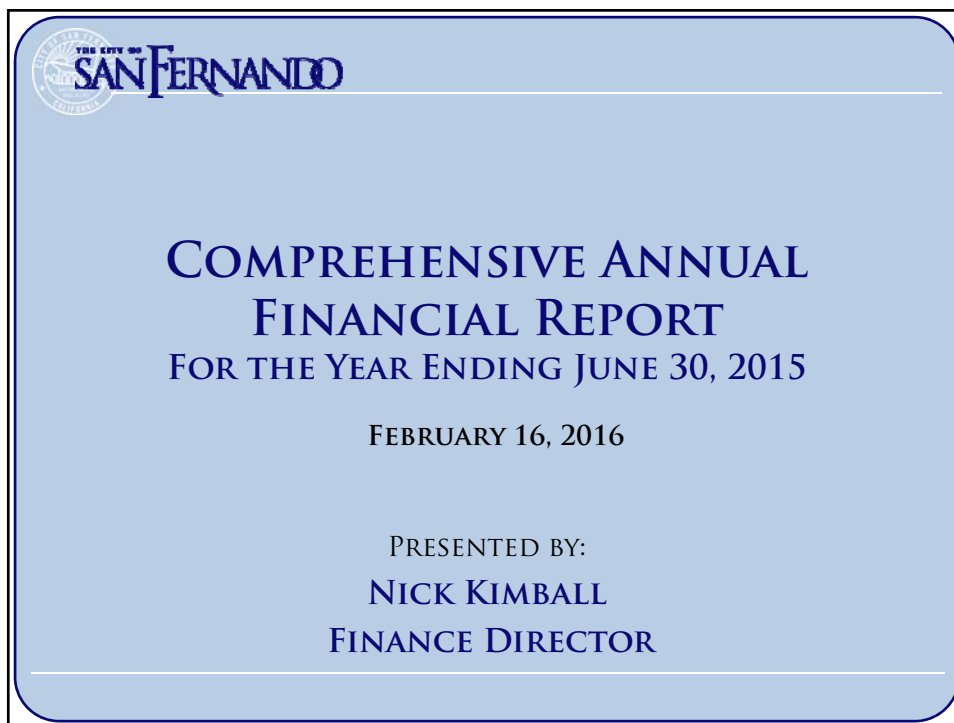

ANNUAL AUDIT REQUIREMENT

Annual audit by independent certified public accountants is required by City Code.

- Financial statements prepared in accordance with GAAP as promulgated by GASB.
 - Audit conducted by Van Lant & Fankhanel, LLP.

GFOA Excellence in Financial Reporting Award.

- Awarded to the City consistently for the last 26 years.
- Received award for June 30, 2014 CAFR.

COMPREHENSIVE ANNUAL FINANCIAL REPORT

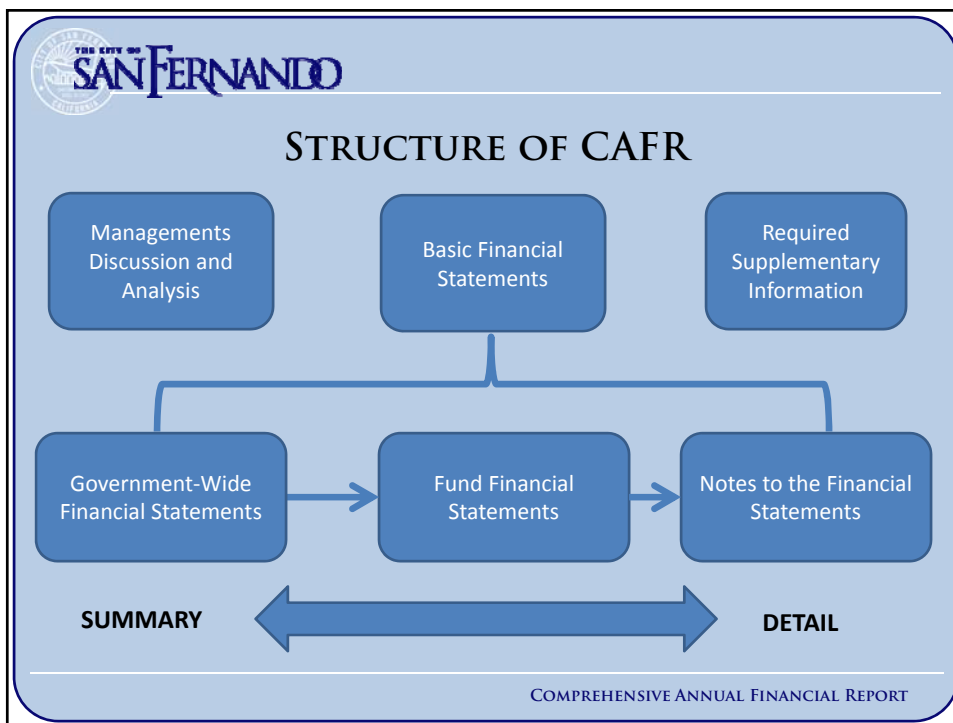



GOVERNMENT-WIDE FINANCIALS

Net Position – Total assets minus total liabilities

- Over time, serves as an indicator of overall financial health.
- Net position decreased by \$29.1 million due primarily to implementation of GASB 68.

Over last 10 years, GASB Pronouncements have had significant impact on Net Position.

- GASB 34 increased reporting of assets.
- GASB 68 increased reporting of liabilities.

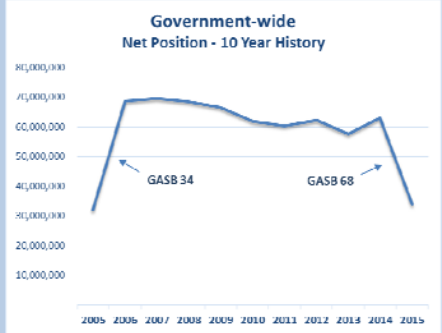

COMPREHENSIVE ANNUAL FINANCIAL REPORT



GASB STATEMENT NO. 68

GASB Statement No. 68 requires governments providing defined benefit pensions (CalPERS) to recognize long-term obligations for pension benefits as a liability, and to more comprehensively and comparably measure the annual cost of pension benefits.

- PERS provided a special GASB 68 compliant Actuarial Report identifying the City's full pension liability (\$26.8 million) rather than just the current year liability.
- Total Miscellaneous Liability: \$12.4 million.
- Total Safety Liability: \$14.4 million.
- Portion attributable to Enterprise Funds: \$1.9 million.

Pension Obligation Tax – Unlike most cities, San Fernando is fortunate to have a dedicated funding stream for Pension costs.

- The Pension Tax can be used to fund annual costs as well as pay down long-term CalPERS obligations.
- **SB 107** has directed Pension Tax revenue formerly given to the Successor Agency to the City. Pension Tax fund collecting additional revenue (primarily from commercial properties in former Project Areas).

COMPREHENSIVE ANNUAL FINANCIAL REPORT



OTHER POST EMPLOYMENT BENEFITS

OPEB (Retiree Health Care) liability continues to grow as the City continues to “pay-as-you go.”

Beginning Liability:	\$9,104,016
Additional Liability:	\$2,697,211
2015 Premiums:	(\$884,963)
Ending Liability:	\$10,916,264

Recent labor negotiations to eliminate RHC for new employees will help limit City’s liability (New OPEB Actuarial study needed).

The City needs to start setting aside funds in a Trust account to pre-fund the liability.

COMPREHENSIVE ANNUAL FINANCIAL REPORT



GOVERNMENTAL FUND FINANCIALS

The City maintains 24 individual governmental funds.

Fund Balance for all Governmental Funds increased from \$6 million to \$8.7 million.

- **Total increase of \$2.7 million.**
- **Primarily result of increased cash in the Retirement and Enterprise funds and retirement of Section 108 and CHFA loans.**

Fund Balances	2015	2014
Nonspendable	\$371,547	\$858,503
Restricted	12,970,716	11,840,461
Unassigned	(4,572,094)	(6,671,972)
TOTAL	\$8,770,169	\$6,026,992

Why did Fund Balance increase while Net Position decreased?

- **Government-wide** reporting provides information on current and long term obligations, including capital assets and long-term liabilities – Useful in assess the City’s overall financial health.
- **Governmental Fund** reporting provides information on near term inflow, outflows and balances of spendable resources – Useful in assessing the City’s ability to meet short term requirements.

COMPREHENSIVE ANNUAL FINANCIAL REPORT



GENERAL FUND

\$1.6 million total deficit reduction; from (\$5.7 million) to (\$4.1 million).

A Closer Look...

Operating Revenues:	\$16,452,730
Operating Expenses:	(\$16,969,333)
Operating (Deficit):	(\$516,603)
One-time Revenues:*	\$3,288,549
One-time Expenses:**	(\$2,593,342)
One-time Surplus:	\$695,207
Total Surplus:	\$178,604

*Measure A - \$2.15 M; Property Sale - \$1 M

**Section 108 and CHFA Loans - \$815,000; Transfer of assets to SIF - \$1.8 million

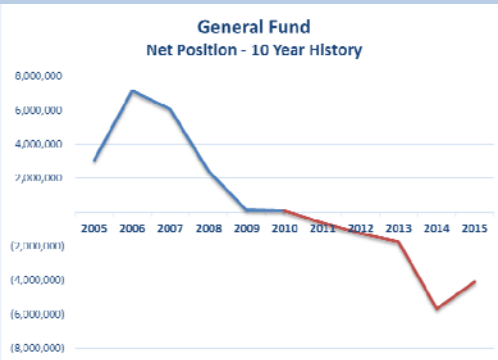

COMPREHENSIVE ANNUAL FINANCIAL REPORT



GENERAL FUND HIGHLIGHTS

Revenue Highlights:

- Strong Measure A revenue, residual property tax revenue from RDA dissolution, and overall improved economic activity.
- \$1 million in land sale proceeds.

Expenditure Highlights:

- Separated Self Insurance assets/liabilities from General Fund to begin building reserve.
- Paid off Section 108 and CHFA loans.
- Reduced Retirement and Las Palmas loans by \$350,000.

COMPREHENSIVE ANNUAL FINANCIAL REPORT

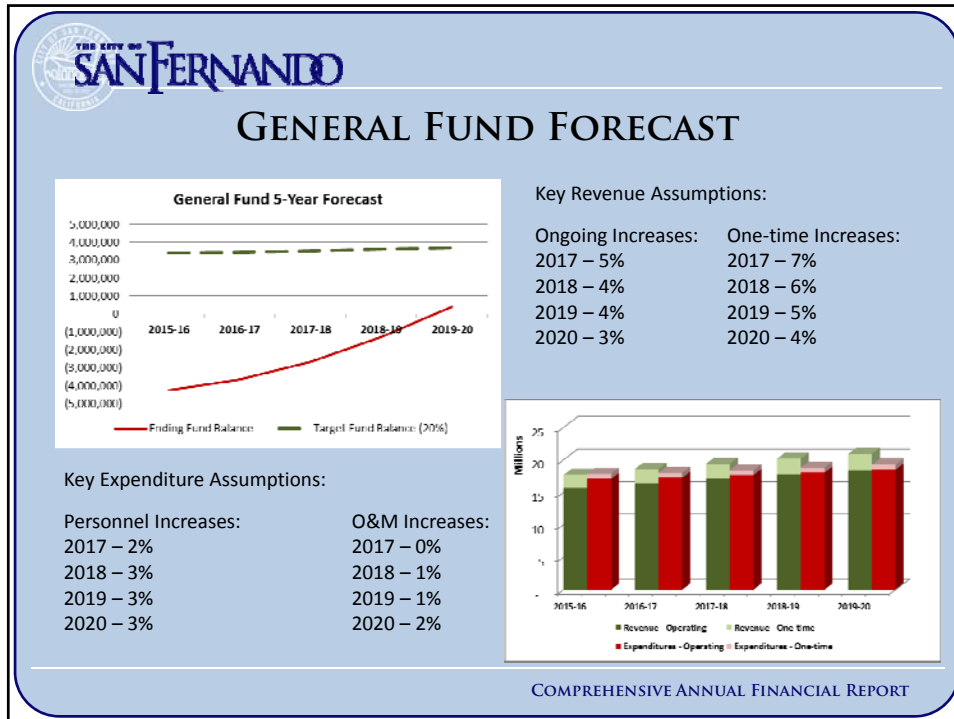

DEFICIT REDUCTION PLAN

Staff has worked with City Council to implement a multi-year plan to eliminate the General Fund deficit.

Over last 18 months, City has:

- Renegotiated the Fire Services contract with LAFD to reduce the annual cost without reducing service (saved more than \$500,000/year).
- Transferred operational and financial responsibility of the Pool to the County of Los Angeles (saved more than \$500,000/year).
- Retired debt from the outstanding California Housing Financing Agency (CHFA) and Section 108 Loans (saved more than \$125,000/year).
- Developed a five-year General Fund projection of revenues and expenditures (improve long term decision making).
- Adopted a Development Agreement Ordinance to increase economic development efforts.
- Sold surplus land and used the land sale proceeds to reduce the City's deficit (\$1 million in proceeds).
- Restructured future retiree health benefits to decrease the City's OPEB liability (significant long-term savings).

COMPREHENSIVE ANNUAL FINANCIAL REPORT

THE CITY OF SAN FERNANDO

DEFICIT REDUCTION PLAN

FY 2015-2016 Budget includes one-time funding for the following items:

- Continue to repay internal debt (\$250,000).
- User fee and cost allocation plan to ensure City is recovering costs for certain services (\$50,000).
- Replace network server infrastructure (\$50,000).
- Re-establish Self Insurance Fund reserve (\$250,000).
- Re-establish Equipment Replacement Fund (\$100,000).
- Establish Facility Capital Replacement Funds (\$50,000).
- Further reduce General Fund deficit (\$200,000).

COMPREHENSIVE ANNUAL FINANCIAL REPORT

THE CITY OF SAN FERNANDO

MEASURE A

- Measure A has been invaluable in keeping the City solvent.
- Since October 2013, Measure A has generated **\$3,442,708** in additional revenue.
- Measure A will sunset in October 2020; right when the City is projected to start emerging from the deficit, which could potentially put the City back in financial turmoil.
- Council may want to consider asking voters to extend Measure A to get San Fernando on strong financial ground and ensure:
 - Regular street maintenance and resurfacing.
 - Regular tree trimming and street sweeping.
 - A high level of public safety services.
 - Meaningful community programs.

Fiscal Year	Budget	Actual
FY 2013-2014*	1,200,000	~1,800,000
FY 2014-2015	1,800,000	~2,200,000

COMPREHENSIVE ANNUAL FINANCIAL REPORT



CONCLUSION

This year's audited financials present mixed signals:

- The General Fund deficit decreased by \$1.5 million; but it continues to have a large deficit fund balance of **(\$4.1 million)**.
- The General Fund realized an overall surplus; but there was an operating deficit of approximately **(\$500,000)**.
- Despite Council action over the last few years to reduce long-term liabilities, the total City-wide "net worth" decreased by \$29.1 million due to a new financial reporting requirement rather than an increase in liability.
- Deficit reduction will continue to be slow and steady as the City works to balance the need to reduce the deficit with the need to replace equipment and infrastructure, address deferred maintenance, and set-aside funds to offset future liabilities.

COMPREHENSIVE ANNUAL FINANCIAL REPORT



Questions?

THE CITY OF
SAN FERNANDO

*This Page
Intentionally
Left Blank*



AGENDA REPORT

To: Mayor Joel Fajardo and Councilmembers

From: Brian Saeki, City Manager
By: Nick Kimball, Finance Director

Date: February 16, 2016

Subject: Presentation of Fiscal Year 2015-2016 Mid-Year Budget Review and Fiscal Year (FY) 2016-2017 Budget Outlook

RECOMMENDATION:

It is recommended that the City Council:

- a. Review and discuss the FY 2015-2016 Mid-Year Budget Review and FY 2016-2017 Budget Outlook; and
- b. Adopt Resolution No 7726, amending the City's FY 2015-2016 budget to include the proposed changes.

BACKGROUND:

1. On June 15, 2015, the City Council adopted a Resolution approving the FY 2015-2016 City Budget.
2. Pursuant to the City's Adopted Budget Policy, the City Manager will present a mid-year fiscal review to City Council (typically between January and March). The purpose of the mid-year review is to update City Council on the financial condition of the City and recommend adjustments to the City's Budget that have been identified subsequent to budget adoption.
3. In January and February 2016, the City Manager and Finance Department reviewed revenues and expenditures through December 31, 2015, met with various Departments to review proposed changes, and updated the General Fund's five-year forecast based on the proposed changes.

Fiscal Year 2015-2016 Mid-Year Budget Review and Fiscal Year 2016-2017 Budget OutlookPage 2 of 6

ANALYSIS:**FY 2015-2016 Mid-Year Review**

The FY 2015-2016 mid-year budget review is an essential element in maintaining financial stability. It gives the City Council an opportunity to review the General Fund, make the needed course corrections to achieve a more accurate budget for the current fiscal year (resulting in greater budget transparency), and helps shape the development of the FY 2016-2017 Budget.

General Fund

The General Fund is the chief operating fund for the City. The City adopted a balanced budget for FY 2015-2016 with \$17,578,679 in revenues and \$17,574,272 in expenditures.

Revenues. Total adopted General Fund revenues for FY 2015-2016 were \$17,578,679. Adjusted revenues through January 2016 were \$17,678,679, which includes an increase of \$100,000 in Measure A revenues approved by City Council to fund the Brand Boulevard Median project.

Staff has reviewed receipts through mid-year and believes the current projected revenues are adequate. Only relatively minor adjustments are recommended and will result in a net decrease of about \$190,760, which are noted below:

1. Increase Zoning and Planning Fee revenue by \$12,500 to offset additional cost of contract planning staff to address backlog;
2. Increase Inspection Upon Resale Program revenue by \$12,500 to offset additional cost of contract planning staff to address backlog; and
3. Decrease Transfer from Gas Tax Fund revenue by \$215,760 due to re-allocation of staff resources funded by Gas Tax revenue (this is offset by a reduction in staff costs of \$215,760 that are being re-allocated to the Sewer Fund).

Over the past few years, revenue estimates have been extremely conservative. As a result, actual revenues have significantly outpaced budgeted revenues. For FY 2015-2016, staff invested significant time into putting together realistic projections that are not too conservative yet not too aggressive. This approach does not leave much room for error. Consequently, if certain revenues do not meet projections (e.g. development related fees), the shortfall may not be made up in other revenues and may result in an overall revenue shortfall at year end. Based on mid-year receipts and estimates by staff and the City's financial consultants, revenue is expected to meet current projections. The net result of the proposed changes is a decrease in General Fund revenue to \$17,487,919.

Expenditures. Total adopted General Fund expenditures for FY 2015-2016 were \$17,574,272. Adjusted expenditures through January 2016 were \$17,823,328, which includes a \$100,000 appropriation approved by City Council for the Brand Boulevard Median project, a carryover of

Fiscal Year 2015-2016 Mid-Year Budget Review and Fiscal Year 2016-2017 Budget OutlookPage 3 of 6

\$95,000 from FY 2014-2015 for the NPDES - catch basin screen installation project, and other minor prior year carryovers. Mid-year expenditures were reviewed with each Department Head with the understanding that revenue projections are not expected to support any mid-year budget enhancements.

The primary mid-year adjustments are related to re-allocating money to each operating division to account for salary and benefit increases negotiated by each bargaining unit. Sufficient funds were reserved to cover the negotiated increases, so there is no net budget impact.

The key changes are noted below:

1. Re-allocate \$134,151 from Non-Departmental (001-190-0000-4101) to the appropriate salary and benefit accounts in each operational Division to implement the recently negotiated MOUs;
2. Increase of \$12,000 in Advertising in the City Clerk's Office to cover City-wide publication of legal notices;
3. Re-allocate \$20,000 from Appropriate Reserve to City Manager's Office for the quarterly newsletter;
4. Transfer \$95,000 carried over for the NPDES catch basin screen installation project to the Capital Outlay Fund (Fund 032);
5. Increase Community Development professional services by \$30,000 to cover the cost of contract planning staff to address current backlog. Offset by increased fee revenue;
6. Transfer \$5,000 from the Police Department and Recreation and Community Services Department to cover the purchase of a Microwave Transmitter to improve internet connectivity at the parks (used for networking of RCS operations and the virtual patrol system); and
7. Reduce labor distribution in the Streets Division and re-allocate to the Sewer Fund to reflect additional resource needs in the Sewer operation and free up Gas Tax funds for street patching and striping activities.

The adjustments proposed in the General Fund are primarily transfers between accounts. The net result of the proposed changes is a decrease of \$201,352 from the adjusted budget to \$17,621,976.

The mid-year adjustments result in a net budget deficit of \$134,057 in the General Fund. It is anticipated that there will be sufficient savings through position vacancies to end the fiscal year balanced.

Other Funds

In addition to adjustments in the General Fund, there are a number of other funds that require mid-year adjustments. Specifically, budget adjustments are being proposed in the Equipment

Fiscal Year 2015-2016 Mid-Year Budget Review and Fiscal Year 2016-2017 Budget OutlookPage 4 of 6

Maintenance and Replacement Fund, Facility Maintenance Fund, Water, Sewer, and Refuse Funds, Gas Tax Fund, Retirement Fund, and Capital Outlay Fund.

Key changes in the proposed revenue adjustments in other funds are noted below:

1. Increase Retirement Fund revenue by \$1,000,000 to account for Retirement Tax revenues from the former Redevelopment Project Areas that are now being remit to the City due to AB 107; and
2. Increase transfer to Capital Outlay Fund from the General Fund by \$95,000 for the NPDES – catch basin screen installation project.

Key changes in the proposed expenditure adjustments in other funds are noted below:

1. Increase salary and benefit accounts in the Equipment Maintenance, Facility Maintenance, Water and Sewer funds to implement the recently negotiated MOUs;
2. Increase labor distribution in the Sewer Fund to re-allocate Streets Division labor to the Sewer Fund to reflect additional resource needs in the Sewer operation;
3. Allocate \$95,000 of Refuse fund balance toward NPDES – catch basin screen installation to keep refuse run-off out of the drainage system;
4. Allocate \$20,000 of Refuse fund balance to cover additional service bins in the downtown/Mall area;
5. Reduce the transfer from the Gas Tax Fund to the General Fund, due to staff salaries being re-allocated to the Sewer Fund, and re-allocate those funds to cover additional tree trimming services and street patching and striping activity;
6. Increase appropriations in the Retirement Fund to implement recently negotiated MOUs and include \$1,000,000 to reduce the City's long term pension obligation; and
7. Appropriate \$95,000 in the Capital Outlay Fund for the NPDES – catch basin screen installation project.

Council Goals & Priorities. As part of the mid-year budget review, staff has also updated the 2015-2016 City Council Goals and Priorities, which is included as Attachment B.

Fiscal Year 2016-2017 Budget Outlook

In order to meet the budget adoption deadline and give City Council and the public sufficient time to review and consider the City Manager's proposed budget, staff begins making preparations for the budget process in January each year. Preparations include initial revenue projections, providing direction to Departments regarding budget guidelines and expectations (e.g., Reductions in Operations and Maintenance budgets, Maintenance of Effort budgets, funded enhancement requests only, etc.), and planning the calendar to get input from City Council.

Fiscal Year 2015-2016 Mid-Year Budget Review and Fiscal Year 2016-2017 Budget OutlookPage 5 of 6

To facilitate an efficient budget process, staff has developed a proposed calendar of events for the FY 2016-2017 budget process. The purpose of a budget calendar is to provide all parties involved with deadlines for submitting data and budget requests and provide the community opportunities to provide input.

A summary of some of the important dates, including the budget study session(s) and budget adoption, are as follows:

Monday, April 18, 2016

- City Council agenda item to discuss City Council priorities for FY 2016-2017

Thursday, May 12, 2016

- FY 2016-2017 Proposed Budget Book distributed to City Council

Monday, May 16, 2016

- Budget Study Session

Monday, May 23, 2016

- Budget Study Session (if necessary)

Monday, June 20, 2016

- Budget Adoption

Based on initial projections, it is expected that the City Manager will provide Department Heads with the direction to prepare “maintenance of effort” budgets, which means, at a minimum, a plan to provide the same level of service for the same cost.

BUDGET IMPACT:

The proposed adjustments in all funds are primarily transfers from other accounts or other funds with no net impact. Revenue and expenditure projections for FY 2015-2016 were realistic; not too conservative yet not too aggressive. Consequently, the mid-year adjustments are proposed to re-allocate currently budgeted resources with very little net budget impact.

CONCLUSION:

Adopting the proposed mid-year adjustments will provide staff with the budget authority to make the needed course corrections and achieve a more accurate budget for the current fiscal year and provide the basis for developing the FY 2016-2017 Budget.

Fiscal Year 2015-2016 Mid-Year Budget Review and Fiscal Year 2016-2017 Budget OutlookPage 6 of 6

ATTACHMENTS:

- A. Resolution No. 7726 (including Exhibit A: Summary of FY 2015-2016 Proposed Mid-year Budget Adjustments)
- B. Updated City Council Goals and Priorities
- C. Preliminary FY 2016-2017 Budget Calendar

ATTACHMENT "A"**RESOLUTION NO. 7726****A RESOLUTION OF THE CITY COUNCIL OF THE CITY OF
SAN FERNANDO AMENDING THE ADOPTED BUDGET FOR
FISCAL YEAR 2015-2016**

WHEREAS, the City Council has received and considered the proposed adjustment to the budget for Fiscal Year 2016, commencing July 1, 2015, and ending June 30, 2016; and

WHEREAS, the purpose of the mid-year adjustment is to update community on the financial condition of the City and recommend adjustments to the City's Budget that have been identified subsequent to budget adoption; and

WHEREAS, the City Council has determined that it is necessary to adjust the expenditures and revenues of the current City budget; and

WHEREAS, an annual budget for the City of San Fernando for the Fiscal Year beginning July 1, 2015 and ending June 30, 2016, a copy of which is on file in the City Clerk's Office, was been adopted on June 15, 2015.

NOW, THEREFORE, THE CITY COUNCIL OF THE CITY OF SAN FERNANDO DOES HEREBY RESOLVE, FIND, DETERMINE AND ORDER AS FOLLOWS:

Section 1. The City Council hereby amends the adopted Budget to adjust the expenditures and revenues as provided in Exhibit "1", attached hereto.

PASSED, APPROVED, AND ADOPTED this 16th day of February 2016.

Joel Fajardo, Mayor

ATTEST:

Elena G. Chávez, City Clerk

STATE OF CALIFORNIA)
COUNTY OF LOS ANGELES) ss
CITY OF SAN FERNANDO)

I HEREBY CERTIFY that the foregoing Resolution was approved and adopted at a regular meeting of the City Council held on the 16th day of February, 2016, by the following vote to wit:

AYES:

NOES:

ABSENT:

Elena G. Chávez, City Clerk

EXHIBIT 1

GENERAL FUND
FY 2015-2016 MID-YEAR BUDGET ADJUSTMENTS

TOTAL GENERAL FUND REVENUES							17,678,679			
Fund Acct. Proj.		REVENUE Account Title		2016 Total Budget	Proposed Adjustment	Proposed Total	Justification:			
001	3705	0000	ZONING AND PLANNING FEES	50,000	12,500	62,500	Increase to offset Evans Brooks contract.			
001	3714	0000	INSPECTION UPON RESALE PROGRAM	15,000	12,500	27,500	Increase to offset Evans Brooks contract.			
001	3961	0000	TRANSFER FROM GAS TAX FUND	289,198	(215,760)	73,438	Salaries in 311 transferred to Sewer; reduce Gas Tax accordingly			
Subtotal Revenue Adjustments					(190,760)					
TOTAL ADJUSTED GENERAL FUND REVENUES							17,487,919			
TOTAL EXPENDITURES							17,823,328			
Fund Div. Proj. Acct.		EXPENDITURE Account Title		2016 Total Budget	Proposed Adjustment	Proposed Total	Justification:			
001	101	0000	4126 HEALTH INSURANCE	22,086	12,000	34,086	Implement MOU.			
001	101	0000	4390 VEHICLE ALLOW & MILEAGE	6,000	3,600	9,600	Implement MOU.			
001	102	0000	4101 SALARIES-PERMANENT EMPLOYEES	105,275	1,316	106,591	Implement MOU.			
001	105	0000	4101 SALARIES-PERMANENT EMPLOYEES	257,958	3,224	261,182	Implement MOU.			
001	105	0000	4230 ADVERTISING	-	20,000	20,000	Transfer from appropriated reserve to cover qtrly newsletter.			
001	106	0000	4101 SALARIES-PERMANENT EMPLOYEES	171,621	2,145	173,766	Implement MOU.			
SUBTOTAL ADMINISTRATION					42,285					
001	115	0000	4101 SALARIES-PERMANENT EMPLOYEES	94,937	14,241	109,178	Implement MOU.			
001	115	0000	4111 COMMISSIONER REIMBURSEMENT	-	3,600	3,600	Transfer Education Commission expenses from RCS Dept.			
001	115	0000	4140 WELLNESS BENEFIT REIMBURSEMENT	-	600	600	Implement MOU.			
001	115	0000	4230 ADVERTISING	1,350	12,000	13,350	Increase to account for legal notices.			
001	115	0000	4450 EDUCATION COMMISSION EXPENSES	-	3,000	3,000	Transfer Education Commission expenses from RCS Dept.			
SUBTOTAL CITY CLERK					33,441					
001	130	0000	4101 SALARIES-PERMANENT EMPLOYEES	305,452	13,818	319,270	Implement MOU.			
001	130	0000	4140 WELLNESS BENEFIT REIMBURSEMENT	-	600	600	Implement MOU.			
001	130	0000	4390 VEHICLE ALLOW & MILEAGE	-	3,600	3,600	Implement MOU.			
001	135	0000	4260 CONTRACTUAL SERVICES	263,925	(18,500)	245,425	Transfer to 001-135-0000-4500 to cover software.			
001	135	0000	4500 ****CAPITAL EXPENSES****	55,500	23,500	79,000	Transfer from divs. 222/420 to cover microwave and software.			
001	190	0000	4101 SALARIES-PERMANENT EMPLOYEES	150,000	(134,151)	15,849	Transfer to operating division to cover MOU increases.			
001	190	0000	4267 APPROPRIATED RESERVE	75,000	(20,000)	55,000	Transfer to Admin for Newsletter.			
001	190	0000	4932 TRANSFER TO CAPITAL PROJECTS	-	95,000	95,000	Transfer to Capital Projects fund for NPDES.			
SUBTOTAL FINANCE					(36,133)					

GENERAL FUND
FY 2015-2016 MID-YEAR BUDGET ADJUSTMENTS

				EXPENDITURE					
Fund	Div.	Proj.	Acct.	Account Title	2016 Total Budget	Proposed Adjustment	Proposed Total	Justification:	
001	140	0000	4101	SALARIES-PERMANENT EMPLOYEES	158,634	1,983	160,617	Implement MOU.	
001	140	0000	4140	WELLNESS BENEFIT REIMBURSEMENT	-	200	200	Implement MOU.	
001	140	0000	4390	VEHICLE ALLOW & MILEAGE	-	1,200	1,200	Implement MOU.	
001	150	0000	4101	SALARIES-PERMANENT EMPLOYEES	135,309	1,691	137,000	Implement MOU.	
001	150	0000	4140	WELLNESS BENEFIT REIMBURSEMENT	-	200	200	Implement MOU.	
001	150	0000	4270	PROFESSIONAL SERVICES	46,242	30,000	76,242	Increase Evans Brooks contract; offset by revenue.	
001	150	0000	4390	VEHICLE ALLOW & MILEAGE	-	1,200	1,200	Implement MOU.	
001	152	0000	4101	SALARIES-PERMANENT EMPLOYEES	187,436	2,343	189,779	Implement MOU.	
001	152	0000	4103	WAGES-PART TIME EMPLOYEES	71,216	(5,000)	66,216	Reduce PT salary to cover additional Evans Brooks contract.	
001	152	0000	4140	WELLNESS BENEFIT REIMBURSEMENT	-	200	200	Implement MOU.	
001	152	0000	4390	VEHICLE ALLOW & MILEAGE	-	1,200	1,200	Implement MOU.	
<i>SUBTOTAL COMMUNITY DEVELOPMENT DEPARTMENT</i>						<i>35,217</i>			
001	222	0000	4101	SALARIES-PERMANENT EMPLOYEES	421,137	5,264	426,401	Implement MOU.	
001	222	0000	4320	DEPARTMENT EQUIPMENT MAINT	40,950	(2,500)	38,450	Transfer to 135 to cover cost of microwave transmitter.	
001	224	0000	4101	SALARIES-PERMANENT EMPLOYEES	475,973	5,950	481,923	Implement MOU.	
001	225	0000	4101	SALARIES-PERMANENT EMPLOYEES	2,649,208	33,115	2,682,323	Implement MOU.	
001	225	0000	4103	WAGES-TEMPORARY & PART-TIME	30,510	(30,510)	-	Transfer all PT Reserve salaries to Div. 226.	
001	225	0000	41xx	RETIREE HEALTH SAVINGS CONTRIBUTION	-	3,600	3,600	Implement MOU.	
001	226	0000	4103	PART-TIME EMPLOYEES	22,750	30,510	53,260	Transfer all PT Reserve salaries to Div. 226.	
001	226	0230	4380	SUBSCRIPTION DUES & MMBRSHIPS	8,750	(7,000)	1,750	Transfer to Explorer program to reflect actual activity.	
001	226	0230	4430	EXPLORER POST PROGRAM	500	7,000	7,500	Transfer from Subscriptions to reflect actual activity.	
<i>SUBTOTAL POLICE DEPARTMENT</i>						<i>45,429</i>			
001	310	0000	4101	SALARIES-PERMANENT EMPLOYEES	229,262	2,293	231,555	Implement MOU.	
001	310	0000	4390	VEHICLE ALLOW & MILEAGE	500	3,600	4,100	Implement MOU.	
001	311	0000	4101	SALARIES-PERMANENT EMPLOYEES	118,774	(118,774)	-	Transfer salaries to Sewer Fund.	
001	311	0000	4103	WAGES-TEMPORARY & PART-TIME	35,561	(35,561)	-	Transfer salaries to Sewer Fund.	
001	311	0000	4105	OVERTIME	7,500	(7,500)	-	Transfer salaries to Sewer Fund.	
001	311	0000	4120	O.A.S.D.I.	9,086	(9,086)	-	Transfer salaries to Sewer Fund.	
001	311	0000	4126	HEALTH INSURANCE	26,467	(26,467)	-	Transfer salaries to Sewer Fund.	
001	311	0000	4128	DENTAL INSURANCE	2,661	(2,661)	-	Transfer salaries to Sewer Fund.	
001	311	0000	4130	WORKER'S COMPENSATION INS.	14,898	(14,898)	-	Transfer salaries to Sewer Fund.	
001	311	0000	4136	OPTICAL INSURANCE	609	(609)	-	Transfer salaries to Sewer Fund.	
001	311	0000	4138	LIFE INSURANCE	204	(204)	-	Transfer salaries to Sewer Fund.	
001	311	0842	4500	NPDES - PIPE SCREEN INSTALL	95,000	(95,000)	-	Transfer to Capital Outlay fund (032) for NPDES project.	
001	346	0000	4101	SALARIES-PERMANENT EMPLOYEES	57,564	576	58,140	Implement MOU.	
001	370	0000	4101	SALARIES-PERMANENT EMPLOYEES	46,612	466	47,078	Implement MOU.	
001	371	0000	4210	UTILITIES	23,192	(23,192)	-	Utilities paid from 390.	
<i>SUBTOTAL PUBLIC WORKS</i>						<i>(327,017)</i>			

GENERAL FUND
FY 2015-2016 MID-YEAR BUDGET ADJUSTMENTS

Fund	Div.	Proj.	Acct.	EXPENDITURE			Justification:	
				Account Title	2016 Total Budget	Proposed Adjustment		Proposed Total
001	420	0000	4101	SALARIES-PERMANENT EMPLOYEES	216,911	6,507	223,418	Implement MOU.
001	420	0000	4111	EDUCATION COMMISSION REIMBURSEMENT	3,000	(3,000)	-	Transfer Education Commission to City Clerk
001	420	0000	4140	WELLNESS BENEFIT REIMBURSEMENT	-	600	600	Implement MOU.
001	420	0000	4260	CONTRACTUAL SERVICES	75,000	(2,500)	72,500	Transfer to 135 to cover cost of microwave transmitter.
001	420	0000	4390	VEHICLE ALLOW & MILEAGE	-	3,600	3,600	Implement MOU.
001	420	0000	4450	EDUCATION COMMISSION EXPENSES	3,000	(3,000)	-	Transfer Education Commission to City Clerk
001	422	0000	4101	SALARIES-PERMANENT EMPLOYEES	110,342	1,379	111,721	Implement MOU.
001	422	0000	4103	WAGES-TEMPORARY & PART-TIME	31,260	(31,260)	-	Transfer all RCS PT salaries to 423.
001	423	0000	4101	SALARIES-PERMANENT EMPLOYEES	73,188	915	74,103	Implement MOU.
001	423	0000	4103	WAGES-TEMPORARY & PART-TIME	95,891	92,156	188,047	Transfer all RCS PT salaries to 423.
001	424	0000	4101	SALARIES-PERMANENT EMPLOYEES	73,983	925	74,908	Implement MOU.
001	424	0000	4103	WAGES-TEMPORARY & PART-TIME	60,896	(60,896)	-	Transfer all RCS PT salaries to 423.
<i>SUBTOTAL RECREATION & COMMUNITY SERVICE</i>						<i>5,426</i>		
<i>Subtotal Expenditure Adjustments</i>						<i>(201,352)</i>		
TOTAL ADJUSTED GENERAL FUND EXPENDITURES						17,621,976		
TOTAL ADJUSTED GENERAL FUND SURPLUS(DEFICIT)						(134,057)		

INTERNAL SERVICE FUNDS
FY 2015-2016 MID-YEAR BUDGET ADJUSTMENTS

EQUIPMENT MAINTENANCE & REPLACEMENT FUND

Beginning Fund Balance: -

TOTAL EQUIPMENT MAINTENANCE REVENUES							852,166
Fund	Acct.	Proj.	REVENUE Account Title	2015 Total Budget	Proposed Adjustment	Proposed Total	Justification:
041			NO REVENUE ADJUSTMENT	-	-	-	
TOTAL ADJUSTED EQUIPMENT MAINTENANCE REVENUES							852,166

TOTAL EQUIPMENT MAINTENANCE EXPENDITURES							822,251	
Fund	Div.	Proj.	Acct.	EXPENDITURE Account Title	2015 Total Budget	Proposed Adjustment	Proposed Total	Justification:
041	320	0000	4101	SALARIES-PERMANENT EMPLOYEES	171,792	2,147	173,939	Implement MOU.
							2,147	
TOTAL ADJUSTED EQUIPMENT MAINTENANCE EXPENDITURES							824,398	
TOTAL ADJUSTED EQUIPMENT MAINTENANCE AND REPLACEMENT FUND SURPLUS(DEFICIT)							27,768	

FACILITY MAINTENANCE FUND

Beginning Fund Balance: -

TOTAL FACILITY MAINTENANCE REVENUES							1,007,365
Fund	Acct.	Proj.	REVENUE Account Title	2015 Total Budget	Proposed Adjustment	Proposed Total	Justification:
043			NO REVENUE ADJUSTMENT	-	-	-	
TOTAL ADJUSTED FACILITY MAINTENANCE REVENUES							1,007,365

TOTAL FACILITY MAINTENANCE EXPENDITURES							1,004,843	
Fund	Div.	Proj.	Acct.	EXPENDITURE Account Title	2015 Total Budget	Proposed Adjustment	Proposed Total	Justification:
043	390	0000	4101	SALARIES-PERMANENT EMPLOYEES	266,272	3,328	269,600	Implement MOU
							3,328	
TOTAL ADJUSTED FACILITY MAINTENANCE EXPENDITURES							1,008,171	

TOTAL ADJUSTED FACILITY MAINTENANCE FUND SURPLUS(DEFICIT)

(806)

FY 2015-2016 MID-YEAR BUDGET ADJUSTMENTS

WATER FUND

Beginning Fund Balance:				2,814,703				
TOTAL WATER FUND REVENUES				3,057,000				
Fund	Acct.	Proj.	REVENUE Account Title	2015 Total Budget	Proposed Adjustment	Proposed Total	Justification:	
070			NO REVENUE ADJUSTMENTS	-	-	-		
ADJUSTED WATER FUND REVENUES				3,057,000				
WATER FUND OPERATING EXPENDITURES				3,346,407				
Fund	Div.	Proj.	Acct.	EXPENDITURE Account Title	2015 Total Budget	Proposed Adjustment	Proposed Total	Justification:
070	381	0000	4101	SALARIES-PERMANENT EMPLOYEES	656,904	8,211	665,115	Implement MOU.
070	382	0000	4101	SALARIES-PERMANENT EMPLOYEES	73,173	915	74,088	Implement MOU.
						9,126		
ADJUSTED WATER FUND OPERATING EXPENDITURES				3,355,533				
WATER FUND CAPITAL EXPENDITURES				1,810,882				
Fund	Div.	Proj.	Acct.	CAPITAL EXPENDITURE Account Title	2015 Total Budget	Proposed Adjustment	Proposed Total	Justification:
070	385	0000	4500	NO CAPITAL ADJUSTMENTS	-	-	-	
ADJUSTED WATER FUND CAPITAL EXPENDITURES				1,810,882				
TOTAL ADJUSTED WATER FUND SURPLUS(DEFICIT)				705,288				

ENTERPRISE FUNDS
FY 2015-2016 MID-YEAR BUDGET ADJUSTMENTS

SEWER FUND

Beginning Fund Balance:				5,885,961				
TOTAL SEWER FUND REVENUES				2,957,000				
Fund	Acct.	Proj.	REVENUE Account Title	2015 Total Budget	Proposed Adjustment	Proposed Total	Justification:	
072			NO REVENUE ADJUSTMENTS	-	-	-		
ADJUSTED SEWER FUND REVENUES				2,957,000				
SEWER FUND OPERATING EXPENDITURES				3,317,560				
Fund	Div.	Proj.	Acct.	EXPENDITURE Account Title	2015 Total Budget	Proposed Adjustment	Proposed Total	Justification:
072	360	0000	4101	SALARIES-PERMANENT EMPLOYEES	349,840	118,774	468,614	Transfer salaries from Division 311.
072	360	0000	4103	WAGES-TEMPORARY & PART-TIME	9,077	35,561	44,638	Transfer salaries from Division 311.
072	360	0000	4105	OVERTIME	7,500	7,500	15,000	Transfer salaries from Division 311.
072	360	0000	4120	O.A.S.D.I.	26,420	9,086	35,506	Transfer salaries from Division 311.
072	360	0000	4124	RETIREMENT	11,269	35,658	46,927	Appropriate Sewer Fund retirement costs.
072	360	0000	4126	HEALTH INSURANCE	59,273	26,467	85,740	Transfer salaries from Division 311.
072	360	0000	4128	DENTAL INSURANCE	6,206	2,661	8,867	Transfer salaries from Division 311.
072	360	0000	4130	WORKER'S COMPENSATION INS.	28,110	14,898	43,008	Transfer salaries from Division 311.
072	360	0000	4134	LONG TERM DISABILITY INSURANCE	442	-	442	Transfer salaries from Division 311.
072	360	0000	4136	OPTICAL INSURANCE	1,473	609	2,082	Transfer salaries from Division 311.
072	360	0000	4138	LIFE INSURANCE	521	204	725	Transfer salaries from Division 311.
				251,418				
ADJUSTED SEWER FUND OPERATING EXPENDITURES				3,568,978				
SEWER FUND CAPITAL EXPENDITURES				2,183,552				
Fund	Div.	Proj.	Acct.	CAPITAL EXPENDITURE Account Title	2015 Total Budget	Proposed Adjustment	Proposed Total	Justification:
070	365	0000	4500	NO CAPITAL ADJUSTMENTS	-	-	-	
ADJUSTED SEWER FUND CAPITAL EXPENDITURES				2,183,552				
TOTAL ADJUSTED SEWER FUND SURPLUS(DEFICIT)				3,090,431				

FY 2015-2016 MID-YEAR BUDGET ADJUSTMENTS

REFUSE FUND

Beginning Fund Balance:				132,924				
TOTAL REFUSE FUND REVENUES				-				
Fund	Acct.	Proj.	REVENUE Account Title	2015 Total Budget	Proposed Adjustment	Proposed Total	Justification:	
073			NO REVENUE ADJUSTMENTS	-	-	-		
ADJUSTED REFUSE FUND REVENUES				-				
REFUSE FUND EXPENDITURES				-				
Fund	Div.	Proj.	Acct.	EXPENDITURE Account Title	2015 Total Budget	Proposed Adjustment	Proposed Total	Justification:
073	350	0000	4300	DEPARTMENT SUPPLIES	-	20,000	20,000	Additional bin service in downtown/mall area.
073	350	0842	4500	NPDES - PIPE SCREEN INSTALL	-	95,000	95,000	Appropriate funds to address NPDES mandate.
				115,000				
ADJUSTED REFUSE FUND EXPENDITURES				115,000				
TOTAL ADJUSTED REFUSE FUND SURPLUS(DEFICIT)				17,924				

FY 2015-2016 MID-YEAR BUDGET ADJUSTMENTS

GAS TAX FUND

Beginning Fund Balance:				547,171				
TOTAL REVENUES				543,470				
Fund	Acct.	Proj.	REVENUE Account Title	2016 Total Budget	Proposed Adjustment	Proposed Total	Justification:	
011			No Revenue Adjustments	-	-	-		
TOTAL ADJUSTED REVENUES				543,470				
TOTAL EXPENDITURES				1,116,602				
Fund	Div.	Proj.	Acct.	EXPENDITURE Account Title	2016 Total Budget	Proposed Adjustment	Proposed Total	Justification:
011	190	0000	4901	TRANSFER TO GENERAL FUND	289,198	(215,760)	73,438	Reduce transfer to cover staff.
011	311	0000	4260	CONTRACTUAL SERVICES	402,457	60,000	462,457	Increase to cover additional tree trimming.
011	311	0560	4600	STREET RESURFACING PROJECTS	-	125,000	125,000	Street patching and striping.
					(30,760)			
TOTAL ADJUSTED EXPENDITURES				1,085,842				
TOTAL ADJUSTED GAS TAX FUND SURPLUS(DEFICIT)				4,799				

SPECIAL REVENUE FUNDS
FY 2015-2016 MID-YEAR BUDGET ADJUSTMENTS

RETIREMENT FUND

Beginning Fund Balance:				218,896				
TOTAL REVENUES				2,974,868				
Fund	Acct.	Proj.	REVENUE Account Title	2016 Total Budget	Proposed Adjustment	Proposed Total	Justification:	
018	3181	0000	PROJECT 1 TAX LEVY	-	70,000	70,000	Appropriate additional revenue per AB 107.	
018	3183	0000	PROJECT 1A TAX LEVY	-	80,000	80,000	Appropriate additional revenue per AB 107.	
018	3185	0000	PROJECT 2 TAX LEVY	-	100,000	100,000	Appropriate additional revenue per AB 107.	
018	3188	0000	PROJECT 3 TAX LEVY	-	200,000	200,000	Appropriate additional revenue per AB 107.	
018	3191	0000	PROJECT 3A TAX LEVY	-	550,000	550,000	Appropriate additional revenue per AB 107.	
				1,000,000				
TOTAL ADJUSTED REVENUES				3,974,868				
TOTAL EXPENDITURES				2,679,366				
Fund	Div.	Proj.	Acct.	EXPENDITURE Account Title	2016 Total Budget	Proposed Adjustment	Proposed Total	Justification:
018	101	0000	4124	RETIREMENT	1,974	1,190	3,164	Appropriate EPMC per MOUs.
018	102	0000	4124	RETIREMENT	10,867	3,810	14,677	Appropriate EPMC per MOUs.
018	105	0000	4124	RETIREMENT	26,937	9,620	36,557	Appropriate EPMC per MOUs.
018	106	0000	4124	RETIREMENT	22,223	7,065	29,288	Appropriate EPMC per MOUs.
018	115	0000	4124	RETIREMENT	12,293	4,055	16,348	Appropriate EPMC per MOUs.
018	130	0000	4124	RETIREMENT	35,025	12,010	47,035	Appropriate EPMC per MOUs.
018	140	0000	4124	RETIREMENT	19,898	6,585	26,483	Appropriate EPMC per MOUs.
018	150	0000	4124	RETIREMENT	16,235	5,405	21,640	Appropriate EPMC per MOUs.
018	152	0000	4124	RETIREMENT	23,628	7,770	31,398	Appropriate EPMC per MOUs.
018	190	0000	4124	RETIREMENT	1,700,000	1,000,000	2,700,000	Additional payment to reduce long term PERS liability.
018	222	0000	4124	RETIREMENT	54,528	14,100	68,628	Appropriate EPMC per MOUs.
018	224	0000	4124	RETIREMENT	66,157	18,620	84,777	Appropriate EPMC per MOUs.
018	225	0000	4124	RETIREMENT	391,363	99,100	490,463	Appropriate EPMC per MOUs.
018	310	0000	4124	RETIREMENT	25,611	8,935	34,546	Appropriate EPMC per MOUs.
018	311	0000	4124	RETIREMENT	14,928	4,950	19,878	Appropriate EPMC per MOUs.
018	320	0000	4124	RETIREMENT	22,245	7,290	29,535	Appropriate EPMC per MOUs.
018	346	0000	4124	RETIREMENT	6,089	2,175	8,264	Appropriate EPMC per MOUs.
018	370	0000	4124	RETIREMENT	5,385	1,870	7,255	Appropriate EPMC per MOUs.
018	390	0000	4124	RETIREMENT	33,080	11,050	44,130	Appropriate EPMC per MOUs.
018	420	0000	4124	RETIREMENT	20,507	7,760	28,267	Appropriate EPMC per MOUs.
018	422	0000	4124	RETIREMENT	12,371	4,365	16,736	Appropriate EPMC per MOUs.
018	423	0000	4124	RETIREMENT	6,919	2,700	9,619	Appropriate EPMC per MOUs.
018	424	0000	4124	RETIREMENT	9,580	3,145	12,725	Appropriate EPMC per MOUs.
				1,243,570				
TOTAL ADJUSTED EXPENDITURES				3,922,936				
TOTAL ADJUSTED RETIREMENT FUND SURPLUS(DEFICIT)				270,828				

**SPECIAL REVENUE FUNDS
FY 2015-2016 MID-YEAR BUDGET ADJUSTMENTS**

CAPITAL OUTLAY FUND

Beginning Fund Balance:							-	
TOTAL REVENUES							100,000	
Fund	Acct.	Proj.	REVENUE Account Title	2016 Total Budget	Proposed Adjustment	Proposed Total	Justification:	
032	3970	0000	TRANSFER FROM GENERAL FUND	100,000	95,000	195,000	Appropriate transfer to fund NPDES project.	
							95,000	
TOTAL ADJUSTED REVENUES							195,000	
TOTAL EXPENDITURES							100,000	
Fund	Div.	Proj.	Acct.	EXPENDITURE Account Title	2016 Total Budget	Proposed Adjustment	Proposed Total	Justification:
032	311	0842	4500	NPDES - PIPE SCREEN INSTALL	-	95,000	95,000	Install catch basin screens to comply with NPDES mandate.
							95,000	
TOTAL ADJUSTED EXPENDITURES							195,000	
TOTAL ADJUSTED CAPITAL OUTLAY FUND SURPLUS(DEFICIT)							-	

CITY COUNCIL GOALS (FY 2015-16)

Goal	Status				Comments
	Done	On Target	Revised	Ongoing	
Continue outreach and opposition of the CHSR route through San Fernando		X		X	City continues to monitor CHSRA Board Meetings, Community Workshops, Technical Studies for EIR/EIS alternatives; City prepared a comment letter/e-mail (October 2015) to Angeles National Forest on geophysical/geotechnical investigation to determine the feasibility of several high speed rail tunnel alignments that the CHSRA is considering through the Angeles National Forest; continue opposition to high speed rail route through the city. The City is also a participant in the North Los Angeles County Communities Protection Coalition with other communities including the City of Santa Clarita, Agua Dulce, Acton, etc. whom oppose the routes that negatively affect our communities.
Continue to stabilize the City's finances by maintaining a balanced budget, continuing to reduce the General Fund deficit, and re-establish reserve balances in a number of critical funds, including but not limited to, the General Fund, Self-Insurance Fund, and Equipment Replacement Fund.		X		X	Staff has developed a five year financial forecast, discussed a deficit reduction plan with City Council, and included the deficit reduction plan as a note in the City's financials. Staff will continue to work with the City Council to implement the plan and sure up the General Fund, SIF, and ERF.
A) Evaluate City service contracts to ensure they are up to date and provisions of contracts are being enforced.		X		X	The City continues to monitor agreements to ensure that competitive pricing and services are received, including: The Recreation and Community Services Department has an agreement for the senior meals program that is scheduled to expire in October 2016; The Police Department has an agreement for linen services that was due to expire in January 2016; The Public Works has a transportation services agreement that is due to expire in June 2016. RFPs have either been or will be issued relative to these services.

CITY COUNCIL GOALS (FY 2015-16)

Goal	Status				Comments
	Done	On Target	Revised	Ongoing	
Pursue Economic Development opportunities to bolster the City's revenue and enhance the City of San Fernando's profile.		X		X	San Fernando Brewing Company (425 Park Avenue); Warehouse Shoe Sale Reopening (460 San Fernando Mission Blvd); Chipotle/Yogurtland/Wing Stop grant opening (1100 Truman Street); Nikki's Pizzeria (913 San Fernando Road); New Community Room at County Library Facility (217 N. Maclay Ave); Magaly's Tamales Restaurant Construction (134 North Maclay Ave); Mariscos Camarena Restaurant (2055 Glenoaks Blvd); and new multi-tenant commercial buildings at 500 San Fernando Mission Blvd. and 1661 San Fernando Road; total construction valuation is 5.4 million.
A) Pursue catalytic projects for the downtown/mall area.		X		X	San Fernando Corridors Specific Plan Update being considered for Planning Commission and City Council review in mid-2016 includes evaluation of mixed-use projects in the downtown including residential, retail, service commercial, and entertainment uses in combination with transportation and other infrastructure enhancements to facilitate new public and private investment in the downtown; City staff is currently exploring redevelopment opportunities consistent with Corridors Specific Plan Redevelopment Strategies.
B) Enhance the City's Business Attraction and Retention Program, including streamlining the permitting and entitlement process.		X		X	Cost of doing business analysis is currently underway; Urgency Ordinance U-1644 established expedited permitting process for small residential solar projects; City evaluating on-line permitting as part of future contracts for city permit issuance software.
C) Explore the opportunity for a farmers' market.		X			The City has submitted an grant application to the USDA for the FINI Corner and Farmers Markets Incentive Program. Staff is awaiting to hear the results of our grant acceptance and award.

CITY COUNCIL GOALS (FY 2015-16)

Goal	Status				Comments
	Done	On Target	Revised	Ongoing	
D) Evaluate reuse options for Lopez/Villegas property, including structure.		X		X	Lopez Villegas House has been designated a local landmark. City has been seeking a possible buyer to relocate structure onto private lot and keep it a local landmark designation; Discussion of possible alternatives to be presented at a City Council Study Session in April 2016 that will include possible alternative option to de-designate it as part of CEQA required environmental assessment.
E) Evaluate the City's minimum wage and living wage ordinances.		X		X	City staff are working with The Valley Economic Alliance on review local, state, and federal legislation to evaluate possible changes to the City's minimum wage and living wage ordinances in conjunction with the cost of doing businesses study.
F) Continue regional collaboration with Metro and neighboring cities to enhance vehicular and pedestrian transportation options within the City of San Fernando		X		X	City staff continues to work with City of Los Angeles and Metro staff regarding the East San Fernando Valley Transit Corridor Project; the City is working on ensuring Metro-project alignment with City's own efforts for multi-modal transportation opportunities under the TOD Overlay/San Fernando Corridors Specific Plan Update; City received a grant from Caltrans to complete a Safe Routes to School Plan. In addition, the County Department of Public Health is collaborating with the City to enhance the Safe Routes Planning and will complete an Active Transportation Plan at no cost to the City.

CITY COUNCIL GOALS (FY 2015-16)

Goal	Status				Comments
	Done	On Target	Revised	Ongoing	
Increase capital expenditures to address critical infrastructure needs, including but not limited to, addressing deferred maintenance of City streets, water and sewer systems, and sidewalks.		X		X	City Council has authorized staff to issue debt secured by County Measure R funds. It is estimated that the City will receive approximately \$2.2 million in March/April 2016 to make street improvements. In addition bids will be advertised in March 2016 for a street resurfacing project including six (6) local streets. The City Council awarded a contract to ADS for flow monitoring services which will identify infiltration into the wastewater system and aide in a analysis of needed system improvements.
A) Evaluate policy for neighborhoods to petition for the installation of speed humps.		X			The City currently has an existing policy regarding the installation of speed humps. The Transportation and Safety Commission met in January 2016 to discuss Safe Routes to School planning efforts which included traffic calming devices (speed humps). This is a grant funded process and is expected to take a year to complete.
Increase the City's use of technology to work more efficiently, increase transparency for citizens and stakeholders, and provide enhanced customer service.		X		X	The City purchased a new network server and software. The new server should be operational in March 2016. Staff has also partnered with Socrata to publish all financial data in an easy-to-understand format. The application is currently operational, however, it will be available to the public with the launch of the new City website.

CITY COUNCIL GOALS (FY 2015-16)

Goal	Status				Comments
	Done	On Target	Revised	Ongoing	
Offer top notch recreation programs through the Healthy San Fernando initiative and explore opportunities to expand sports programs.		X		X	<p>Since March 2015, the RCS has implemented various sport programs for youth/adults, including adult softball, adult volleyball, teen soccer, Futsol, Tennis (all ages), and partnership with the So Cal Special Olympics to provide programs for individuals with disabilities.</p> <p>The City has also issued an RFP for the development of a Parks Master Plan to evaluate goals and objectives for the use and expansion of park services including community and cultural programs at parks. Proposals were submitted and a firm has been selected by staff. Work is tentively slated to begin in July 2016 pending the approval of the FY 2016-17 Budget.</p>
Pursue grant funding that addresses a need and provides a net benefit to the City.		X		X	<p>The City has been awarded the following grants in 2015: Community Development Department - Working on completion of Program EIR for TOD Overlay Project/Corridors Specific Plan Update in order to use EIR (\$282,000 metro grant) to apply for County (Metro Call for Projects), State (Cal Tran Grant/HCD Grant/New Market Tax Credits) and Federal Grants (Economic Development Initiative Grants and Section 108 Loans); Public Works Department - Caltrans Sustainability Planning Grant (\$160,000), Metro Call for Projects Grant for Traffic Signal Synchronization (\$800,000), Housing-Related Parks Grant for Recreation Park Improvements (\$200,000); Mobile Source Air Reduction/Air Quality Management District Grant for Electric Vehicle Charging Infrastructure (\$100,000) and Pacoima Wash Bikeway (\$354,000); Police Department - COPS Grant for 1 Full Time Police Officer Position (\$140,000 over 3 years).</p>

CITY COUNCIL GOALS (FY 2015-16)

Goal	Status				Comments
	Done	On Target	Revised	Ongoing	
Continue to review and update the City's policies and procedures.		X		X	<p>In January 2016, staff met with the Budget, Finance, and Personnel Committee to review and update the City's purchasing ordinance and related purchasing policies.</p> <p>The City Clerk's office worked with City Attorney's Office and completed an update of the City's Records Retention Policy.</p> <p>The Police Department is currently updating their Department Manual, which has been outdated for several years.</p> <p>The Personnel Division is updating the City Personnel Rules, as well as Standard Management Policies and Procedures, which have been outdated for some years.</p>
Explore opportunities for community and cultural programs.		X		X	<p>The City has issued an RFP for the development of a Parks Master Plan to evaluate goals and objectives for the use and expansion of park services including community and cultural programs at parks. Proposals were submitted and a firm has been selected by staff. Work is tentively slated to begin in July 2016 pending the approval of the FY 2016-17 Budget.</p> <p>The Recreation and Community Services Department has partnered with the Ford Foundation to expand cultural arts events (8 JAM Sessions/yr.). In addition, City has partnered with numerous organizations to increase the size and quality of the Dia De Los Muertos event. Currently, staff is working on indigenous programs and additional art programs.</p>
Veteran's appreciate event.		X		X	<p>The Recreation and Community Services Department has explored various celebrations occurring within the Northeast San Fernando Valley and will communicate to all park users.</p>

CITY COUNCIL GOALS (FY 2015-16)

Goal	Status				Comments
	Done	On Target	Revised	Ongoing	
Community Garden		X		X	As part of the Parks Master Plan Project, it will evaluate the possible use of park space at Heritage Park as a community garden. Staff is also exploring other areas in the community that could be developed into a community garden.
Increase water conservation efforts, including but not limited to, community outreach and implementation of water conservation programs.	X			X	In May 2015, the City Council implemented Phase II water conservation efforts including new City Parkway Turf Replacement Guidelines; the City has reduced exterior watering at City facilities; the City continues to follow State water conservation mandates while promoting MWD rebate programs for low-flow toilets and showerheads, and turf replacement programs; the City is looking at expanding alternative planting guidelines to on-site front yard landscaping; and the City has completed construction of a drought tolerant median landscaping project on Brand Boulevard to help save over 1 million gallons of water annually.



ATTACHMENT C

BUDGET CALENDAR

Time Frame	Task	Department(s)
January – April 2016	Review and calculate revenue projections for General Fund, Special Revenue Funds, Enterprise Funds and Capital Projects Funds.	Finance
February 2016	Review/Update salary projections.	Personnel, Finance
February 16, 2016	City Council Study Session to review: <ul style="list-style-type: none"> • FY 2014-2015 Audited Financial Statements • FY 2015-2016 Mid-year Budget • FY 2016-2017 Budget Outlook 	Administration, Finance
February/March 2016	Prepare/update budget instructions and forms for departments to complete during budget development.	Finance
March 22, 2016	City Manager meets with Department Heads to discuss the budget schedule and provide direction regarding budget guidelines (e.g. Maintenance of effort, only funded enhancement requests, etc.). Budget forms distributed.	All Departments
March 22 - 31, 2016	Departments review and complete budget forms.	All Departments
April 4 - 8, 2016	Preliminary review of department budget forms, including review of enhancement and Capital requests.	Administration, Finance
April 11 - 14, 2016	City Manager/Finance Director meetings with Department Heads to discuss budget requests.	All Departments
April 18, 2016	Agenda item to discuss Council priorities for Fiscal Year 2016-2017	Administration, Finance
April 28, 2016	Finalize City Manager's recommendations.	Administration, Finance
April/May 2016	Prepare Proposed Budget document.	Administration, Finance
May 12, 2016	Give Proposed Budget to City Council.	Administration, Finance
May 16, 2016	Budget Study Sessions.	All Departments
May 23, 2016	If necessary, special meeting to continue Budget Study Sessions.	All Departments
May/June 2016	Update Proposed Budget based on direction provided at Budget Study Sessions.	Administration, Finance
June 2, 2016	Publish Notice of Public Hearing for budget adoptions.	City Clerk
June 20, 2016	Budget hearing and adoption, including adopting of Gann Limit.	Administration, Finance
July 1, 2016	Post adopted budget to the City's Finance system.	Finance
Jul/Aug 2016	Produce Adopted Budget book, distribute to City Council, post to the City's website, and submit for GFOA Award.	Finance

*This Page
Intentionally
Left Blank*



AGENDA REPORT

To: Mayor Joel Fajardo and Councilmembers

From: Councilmember Jaime Soto

Date: February 16, 2016

Subject: Consideration to Assess the Potential Enforcement of Emissions of Ice Cream Trucks and Related Vendors

RECOMMENDATION:

I would respectfully request City Council consideration to give City Staff and the City Attorney direction to begin the process of assessing the potential enforcement of toxic emissions from ice cream trucks and related vendors in the City of San Fernando.

*This Page
Intentionally
Left Blank*

10

*This Page
Intentionally
Left Blank*



MEMORANDUM

To: Mayor Joel Fajardo and Councilmembers

From: Councilmember Robert C. Gonzales

Date: February 16, 2016

Subject: Consideration to Assess the Feasibility of Amending the San Fernando City Code to Establish Designated Children Playground Areas

RECOMMENDATION:

I would respectfully request City Council consideration to give City Staff and the City Attorney direction to evaluate the feasibility of preparing a City Ordinance that effectively bans adults unaccompanied by a minor child from entering and/or remaining in a City park playground. The proposed ordinance would make it unlawful for any adult to enter and remain in a designated City park playground area where signage is posted, unless the adult is supervising and/or accompanying child(ren) who is/are then visiting the designated park playground area.

The ordinance would define an adult as anyone over 18 and children as persons age 12 or younger. The City park playground areas would be defined as any portion of an area within a City park that contains playground equipment for use by children, and has been posted with proper signage identifying the designated area as a children's play area. This type of ordinance is similar to City regulations adopted by other communities and is intended to provide additional safeguards for community youths using City park playground areas.

*This Page
Intentionally
Left Blank*

*This Page
Intentionally
Left Blank*



AGENDA REPORT

To: Mayor Joel Fajardo and Councilmembers

From: Brian Saeki, City Manager

Date: February 16, 2016

Subject: Consideration of Opposition to SB 876 (Liu): Homelessness

RECOMMENDATION:

It is recommended that the City Council provide staff with direction related to the League of California Cities opposition to SB 876 (Liu): Homelessness.

BACKGROUND:

SB 876 (Liu): Homelessness, would preempt local authority to address important issues affecting public health and safety in public spaces and on private property that is held open to the public, including not limited to, plazas, courtyards, parking lots, sidewalks, public transportation facilities, public buildings, shopping centers and parks. In such areas, homeless individuals would be empowered to occupy such spaces indefinitely, including with tents and other shelter, while reducing access to all other members of the public.

ANALYSIS:

The League of California Cities has opposed SB 876 for the following reasons:

- SB 876 offers no solutions for homelessness. It offers no new programs, no funding for housing, and no effort to improve services. In fact, on page 3, line 16, the bill specifically states, "Passing this Act will not reduce homelessness."
- The key to getting people off of the streets is to provide more shelter. We need resources to complement our local efforts: permanent housing beds and accompanying social services such as mental health treatment, job training, addiction counseling, etc. Cities and other local agencies need more funding and flexibility to provide these proven programs. Additionally, these services should be provided as a coordinated effort. Removing local enforcement authority as proposed in SB 876 will do nothing to help the problem, and would actually undermine existing efforts.

Consideration of Opposition to SB 876 (Liu): HomelessnessPage 2 of 2

- Local agencies must continue to be able to protect the public, health, safety and welfare of their communities.

SB 876 will be heard in the Senate Transportation and Housing Committee soon. Therefore, the League of California Cities has requested that cities send in letters of opposition as soon as possible so they can be reflected in advance of the hearing. Attached is a copy of the League of California Cities' opposition letter (Attachment "A") and a sample opposition letter (Attachment "B").

BUDGET IMPACT:

There will be no impact to the budget.

ATTACHMENTS:

- A. League of California Cities Opposition Letter
- B. Sample Opposition Letter

ATTACHMENT "A"



1400 K Street, Suite 400 • Sacramento, California 95814
Phone: 916.658.8200 Fax: 916.658.8240
www.cacities.org

February 4, 2016

The Honorable Senator Carol Liu
California State Senate
State Capitol, Room 5097
Sacramento, CA 95814

**RE: SB 876 (Liu) Homelessness
Notice of Opposition**

Dear Senator Liu:

The League of California Cities regrets to inform you of our opposition to your SB 876. As we conveyed to your staff at our recent meeting, we view this measure as preempting local authority to address important issues affecting public health and safety in public spaces and on private property that is held open to the public, including not limited to, plazas, courtyards, parking lots, sidewalks, public transportation facilities, public buildings, shopping centers and parks. We recognize that this measure is well intentioned; however, local agencies must continue to be able to protect the public, health, safety and welfare of their communities. Moreover, we do not believe this measure will make a positive impact in the effort to address chronic homelessness.

Homelessness is a pervasive problem affecting many communities across our state. As a result, many local governments, non-profits and social service providers are trying various creative solutions to get people housed and into the treatment programs they need to permanently get off of the streets. Last fall, the League formed a statewide working group of city officials and staff who are tackling the problem to share best practices and receive input on what is needed to make additional progress with strategies that best serve local needs. The consensus was clear: legislation that seeks to combat homelessness should focus on solutions and provide resources that help get people off of the streets and into shelter and housing.

The key to getting people off of the streets is to provide more shelter, permanent housing beds and accompanying social services such as mental health treatment, job training, addiction counseling, etc. Cities and other local agencies need more funding and flexibility to provide these proven programs. Additionally, these services should be provided as a coordinated effort. We have heard from members of our working group that many cities have formed special task forces on homelessness that combine city, county, law enforcement, social service providers and non-profits all working together to come up with creative ways they can partner and address the homeless problem.

In our discussions with local officials who are working on a daily basis on these issues, the consensus was clear. Removing local enforcement authority as you propose in SB 876 will do

nothing to help the problem, and would actually undermine existing efforts. SB 876 contains no solutions for ending homelessness. In fact, the bill on page 3, line 16, specifically states, "Passing this Act will not reduce homelessness." Removing local authority could exacerbate the problem by removing incentives for some to take advantage of existing resources and services being offered. For example, some local jurisdictions host legal clinics where homeless clinic participants can have citations and related fines removed from their records in exchange for community service and for taking advantage of housing and other services.

While we oppose this measure's approach, the League is committed to supporting efforts across the state and in our communities that address the homeless issue in a constructive manner. In that vein, we are encouraged by Senator de León's recent "No Place Like Home" proposal that will provide much needed funding for housing for the mentally ill homeless, and augmentations to existing shelter resources. We look forward to supporting such efforts to develop resources to provide affordable housing and services to actually serve our chronically homeless and help them get off of the streets.

The League is genuinely interested in finding workable solutions to this growing problem. We appreciate the meeting we had with your staff where we expressed our concerns, and we look forward to continued discussions.

If you have any questions or if I can be of any assistance, please call me at (916) 658-8250.

Sincerely,

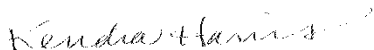

Kendra Harris
Legislative Representative

Cc: Chair and Members, Senate Committee on Transportation and Housing
Alison Dinmore, Consultant, Senate Committee on Transportation and Housing
Doug Yoakam, Housing Consultant, Senate Republican Caucus

ATTACHMENT "B"*****On City Letterhead*******DATE**

The Honorable Senator Carol Liu
 California State Senate
 State Capitol, Room 5097
 Sacramento, CA 95814
 FAX: (916) 651-4925

RE: SB 876 (Liu) Enforcement of Local Ordinances
Notice of OPPOSITION

Dear Senator Liu:

On behalf of the **City/Town of _____** I regret to inform you of our opposition of Senate Bill 876 (Liu).

This measure is preempting local authority to address important issues affecting public health and safety in public spaces and on private property that is held open to the public, including not limited to, plazas, courtyards, parking lots, sidewalks, public transportation facilities, public buildings, shopping centers and parks. We recognize that this measure is well intentioned; however, local agencies must continue to be able to protect the public, health, safety and welfare of their communities. Moreover, we do not believe this measure will make a positive impact in the effort to address chronic homelessness.

Removing local enforcement authority as you propose in SB 876 will do nothing to help the problem, and would actually undermine existing efforts. SB 876 contains no solutions for ending homelessness. In fact, the bill on page 3, line 16, specifically states, "Passing this Act will not reduce homelessness." Removing local authority could exacerbate the problem by removing incentives for some to take advantage of existing resources and services being offered.

The key to getting people off of the streets is to provide more shelter. We need resources: permanent housing beds and accompanying social services such as mental health treatment, job training, addiction counseling, etc. Cities and other local agencies need more funding and flexibility to provide these proven programs.

[INSERT YOUR COMMUNITY'S EFFORTS IN SOLVING HOMELESSNESS]

Once again, the **City/Town of _____** regrets to inform you of our opposition to SB 876.

Sincerely,

NAME

TITLE

CITY/TOWN of _____

cc: **Your Senator & Assembly Member**

Alison Dinmore, Consultant, Senate Committee on Transportation and Housing, fax: (916) 445-2209

Doug Yoakam, Housing Consultant, Senate Republican Caucus, fax: (916) 445-2209

Your League Regional Public Affairs Manager (via email)

Meg Desmond, League of California Cities, mdesmond@cacities.org