

**CITY OF SAN FERNANDO
CALIFORNIA**

**CONTRACT DOCUMENTS,
SPECIFICATIONS AND STANDARD DRAWINGS
FOR
FOG SEAL COATING AND STRIPING OF CITY PARKING
LOTS
JOB NO. 7627**



Prepared by: Manuel Fabian

Date: 06/06/2024

Prepared Under the Supervision of: Wendell Johnson, PE

Date: 06/06/2024

TABLE OF CONTENTS

SECTION	Page No.
Information	
Table of Contents	(i)
Notice Inviting Bids	1
Instructions to Bidders	3
Proposal	
Contractor’s Proposal	P-1
Bid Schedule	P-2
Bidder’s Bond	P-4
Contractor Information	P-6
List of References	P-7
List of Subcontractors.....	P-8
Certificate of Secretary of Adoption of Resolution	P-9
List of Subcontractors, Suppliers, & Vendors Contacted.....	P-10
Non-Collusion Affidavit	P-11
Contract/Agreement	
Construction Contract.....	C-1
Performance Bond Form.....	C-4
Payment (Labor and Material) Bond Form	C-6
Warranty Performance and Payment Bond Form	C-8
General Provisions	
Section 1 – Terms, Definitions, Abbreviations, and Symbols	GP-1
Section 2 – Scope of the Work.....	GP-2
Section 3 – Control of the Work	GP-6
Section 4 – Control of Materials.....	GP-8
Section 5 – Legal Relations and Responsibilities	GP-8
Section 6 – Prosecution and Progress of the Work.....	GP-10
Section 7 – Measurement and Payment	GP-11
Section 8 – Facilities for Agency Personnel.....	GP-12
Section 400 – Protection and Restoration of Existing Improvements	GP-13
Section 402 – Utilities	GP-13
Section 601 – Temporary Traffic Control for Construction and Maintenance Work Zones	GP-13
Special Provisions	
Part 1 – Seal Coats and Crack Treatments	SP-1
Part 2 - Signing, Striping, And Pavement Markers.....	SP-5
Part 3 - Mobilization	SP-8

NOTICE INVITING BIDS

SEALED PROPOSALS will be received at the Office of the City Clerk, City Hall, 117 Macneil Street, San Fernando, California until **11:00 AM on Thursday, July 11, 2024**. Questions regarding the project are due by end of business on **Wednesday, July 3, 2024** and must be submitted by email only to Manuel Fabian at mfabian@sfcity.org. Bids will be publicly opened and declared for performing work on the following project:

FOG SEAL COATING AND STRIPING OF CITY PARKING LOTS JOB NO. 7627

The City of San Fernando is inviting you to submit a bid for the fog seal coating and striping of City Parking Lots project. This project primarily consists of fog sealing eight City parking lots, installation of pavement markings and work related to the project.

The work to be performed includes, but is not limited to furnishing all materials, equipment, tools, notifications, labor, and incidentals as required by the specifications, and contract documents for the improvements at various locations throughout the City of San Fernando. The work includes but not limited to: crack sealing; placement of fog seal material; replacement of traffic striping and pavement markings; and clean-up of the project area.

The bid items, corresponding estimated quantities, and time allowed to complete the work are listed in the Contractor's Proposal. The definitions of bid items are described in the Technical Provisions.

An optional pre-bid conference is scheduled for June 25, 2024 at 11:30 am at City Hall, 117 Macneil Street, San Fernando, CA, 91340.

The contract time for the project is FORTY-FIVE (45) working days.

It is the policy of the City, as directed by City Council, to encourage the use of local area businesses in construction contracts including vendors, suppliers, labor, etc.

The City reserves the right to reject any and all bids and to waive any minor irregularities in the bid documents. Bidders may not withdraw their bid for a period of ninety (90) days after date set for opening thereof.

The Contractor must follow the procedures as set forth in the Instructions to Bidders for acceptance of bids. Bids will be accepted only if submitted on a proposal form furnished by the City. Each bid must be accompanied by cash, certified check, cashier's check, or bidder's bond made payable to the City of San Fernando or issued by a surety admitted to do business in California, for an amount equal to at least ten percent (10%) of the amount bid. Such guaranty to be forfeited to the City should the bidder to whom the contract is awarded fail to enter into the contract.

Bids will be accepted only from contractors licensed in accordance with the provisions of the Business and Professional Code of the State of California. Prior to contract execution, the contractor and his/her subcontractors shall obtain a City business license. Prior to beginning work, the prime contractor must possess a valid California **Class A** license or related license as issued by the State of California.

AB44 EFFECTIVE JULY 1, 2014. If a bidder submits a bid that includes a subcontractor who

would be performing work in amount in excess of 1/2 of 1% of the bidder's total bid or in the case of bids for the construction of streets or highways, including bridges, in excess of 1/2 of 1% of the bidder's total bid or \$10,000, whichever is greater, then in addition to the subcontractor's name and business address, the subcontractor's State contractor's license number must be included as part of the information submitted for that proposed subcontractor. Failure to provide the subcontractor's license number shall render the bid non-responsive.

SB854 EFFECTIVE MARCH 1, 2015. Contractors and Subcontractors wishing to work on a public works project must be registered with the State of California, Department of Industrial Relations. All public works projects with bids submitted after March 1, 2015, or awarded on or after April 1, 2015, shall use only registered contractors and subcontractors. No bid will be accepted nor any contract entered into without proof of the Bidder's and its subcontractors' current registration with the Department of Industrial Relations. If awarded a contract, the Bidder and its subcontractors of every tier shall maintain active registration with the Department of Industrial Relations for the duration of the Project.

The State General Prevailing Wage Rate Determination as established by the California Department of Industrial Relations is available at <http://www.dir.ca.gov/DLSR/PWD/index.htm> and in the Public Works Department at City Hall.

At the request and expense of the Contractor, securities equivalent to the five percent (5%) to be withheld from progress payments pursuant to the City's Standard General Conditions shall be deposited with the City Clerk or a state or federally chartered bank as the escrow agent, who shall pay such monies to the contractor upon satisfactory completion of the contract. Securities eligible for investment shall include those listed in Section 16430 of the Government Code or bank or savings and loan certificates of deposit. The contractor shall be the beneficial owner of any securities substituted for monies withheld and shall receive any interest thereof.

Copies of the plans and specifications, including the approved proposal form, are available on the City website, www.sfcity.org, for downloading at no charge. **In order to be eligible to submit a bid for the project, you MUST contact Manuel Fabian, Civil Engineering Assistant II, via e-mail at mfabian@sfcity.org to be placed on the plan holders list.**

Addenda, if any, will NOT be distributed to the plan holders, and will ONLY be posted on the City website. **It shall be the Bidder's responsibility to check the City website for any addenda.**

City of San Fernando

Date: 06/13/24

By: Wendell Johnson
Director of Public Works

Thursday
06/13/24

INSTRUCTIONS TO BIDDERS

1. GENERAL Proposals under these Contract Documents shall be submitted on the blank forms furnished herewith. When presented, the proposal forms must be completely made out in the manner and form indicated therein, and must be properly signed by the bidder. The bidder's address, telephone number, and California State Contractor's License number must be included. To be eligible to perform work, the bidder must be a state licensed contractor in good standing prior to beginning work. The City Council reserves the right to reject any bid if all the above information is not furnished.

Each proposal submitted must be presented in a sealed cover, and must be filed prior to the time and at the place designated in the Notice Inviting Bids. All proposals submitted as prescribed will be publicly opened and read at the time and place designated in the Notice Inviting Bids.

Bid Quotes and Unit Price Extensions – The unit prices and the lump sum prices quoted by the bidder must be entered in the spaces provided on the Contractor's Proposal form. In case there is a discrepancy between the unit price and the item total, the unit price shall govern and will be considered as representing the Bidder's intention. The bid total will be corrected to conform to the specified unit price.

Bid Retention and Award – The City reserves the right to retain all bids for a period of ninety (90) days for examination and comparison. The City also reserves the right to waive non-substantial irregularities in any bid, to reject any and all proposals, to reject or delete one part of a proposal and accept the other, except to the extent that the bids are qualified by specific limitations, and to make award to the lowest responsible bidder as the interest of the City may require.

Communications Regarding Bid – All timely requests for information submitted in writing will receive a written response from the City. Telephone communications with City staff are not encouraged, but will be permitted. However, any such oral communication shall not be binding on the City.

2. EXAMINATION OF PLANS, CONTRACT DOCUMENTS, AND WORK SITE The Contract Documents and plans, if any, are on file and available for inspection in City Hall.

The Bidders are required to carefully examine the site and the proposal, plans, Contract Documents, and contract forms. The Bidders must satisfy themselves as to the requirements of the Contract Documents and the contract; as to the location of the proposed work and by such other means as they may prefer; and as to the actual conditions and requirements of the work, and shall not, at any time after submission of the bid, dispute, complain, or assert that there was any misunderstanding in regard to the nature or amount of work to be done. It is mutually agreed that submission of a proposal shall be considered prima facie evidence that the bidder has made such examinations.

3. DISQUALIFICATION OF BIDDERS AND PROPOSALS More than one proposal for the same work from any individual, firm, partnership, corporation or association under the same or different names will not be accepted and reasonable grounds for believing that any bidder is interested in more than one proposal for the work will be cause for rejecting all proposals in which such bidders are interested.

Proposals which show obviously unbalanced prices, and those which are incomplete or show any alteration of form, or contain any additions or conditional or alternate bids that are not called for or otherwise permitted, may be rejected. Proposals that do not bear the Bidder's signature will be

rejected.

4. AWARD AND EXECUTION OF CONTRACT The award of the contract, if awarded, will be made to the lowest responsive bidder whose proposal complies with all the prescribed requirements. The right is reserved, however, to reject any or all bids and to waive technical errors or discrepancies if it is deemed to best serve the interests of the City. An award will be made only until all necessary investigations are made as to the responsiveness of the low bidder.

Failure to execute a contract and file acceptable bonds as provided herein within the above timeline, not including Sundays, shall be just cause for the annulment of the award and the forfeiture of the proposal guaranty.

The Contractor will be required to obtain a City Business License prior to award of the contract.

5. SIGNATURE OF CONTRACTOR

- a. Corporation Any bids submitted by a corporation must include the name of the corporation, and must be signed by the President and Secretary or Assistant Secretary, and the corporate seal must be affixed. Other persons may sign for the corporation in lieu of the above if a certified copy of a resolution of the corporate board of directors so authorizing them to do so is on file in the City Clerk's Office.
- b. Partnerships Any bids submitted by a partnership must contain the names of all persons comprising the partnership or co-partnership. The bid must be signed by all partners comprising the partnership unless proof in the form of a certified copy of a certificate of partnership acknowledging the signer to be a general partner is presented to the City Clerk.
- c. Joint Ventures Any bids submitted by a joint venture must so state that and must be signed by each joint venturer.
- d. Individuals Any bids submitted by an individual must be signed by that individual unless an up-to-date power of attorney is on file in the City Clerk's Office, in which case the person indicated in the power of attorney may sign for the individual.

The above rules also apply in the case of a fictitious firm name. In addition, however, where the fictitious name is used, it must be so indicated where the signature appears.

6. BONDS

- a. Bid Bonds Bid must be accompanied by cash, cashier's check, certified check, or surety bond in an amount equal to ten percent (10%) of the total amount in the Contractor's Proposal. Checks and bonds shall be made payable to the City of San Fernando.
- b. Contract Bonds The Contractor simultaneously with execution of the Agreement shall furnish a surety bond in an amount equal to one hundred percent (100%) of the contract price as security for the faithful performance of this contract and a separate surety bond in an equal to one hundred percent (100%) of the contract price as security for the payment of all persons performing labor and furnishing materials in connection with this contract, as required by the terms of an Act entitled:

"An Act to secure the payment of the claim of persons employed by Contractors upon Public Works, and the claims of persons who furnish materials, supplies, teams, implements; or machinery used or consumed by such Contractors in the performance

of such works, and prescribing the duties of certain public officers with respect thereto," approved May 10, 1919, as amended.

Bond Forms required are included in these specifications. Copies will be furnished to prospective bidders upon request.

Whenever any Surety or Sureties on any such bonds, or any bonds required by Law for the protection of the claims of laborers and material men become insufficient or the City Engineer has cause to believe that such Surety or Sureties have become insufficient, a demand in writing may be made of the Contractor for each further bond or bonds or additional surety, not exceeding that originally required, as is considered necessary, considering the extent of the work remaining to be done. Thereafter, no payment shall be made upon such contract to the Contractor or any assignee of the Contractor until such further bond or bonds or additional surety has been furnished.

7. RETURN OF BIDDER'S GUARANTIES Within ten (10) days after the award of the contract, the City will return the proposal guaranties accompanying those proposals which are not to be considered in making award. All other proposals which are to be held until the contract has been finally executed, will be returned to the respective bidders after award of contract.
8. CONFLICT OF INTEREST In the procurement of supplies, equipment, construction, and services by sub-recipients, the conflict of interest provisions in 24 CFR 85.36, OMB Circular A-110, and 24 CFR 570.611, respectively, shall apply. No employee, officer or agent of the sub-recipient shall participate in selection, or award or administration of a contract supported by Federal funds if a conflict of interest, real or apparent, would be involved.

The following documents in the PROPOSAL section of these Contract Documents must be completed and submitted with the bid package:

- Contractor's Proposal
- Bid Schedule
- Bidder's Bond
- Contractor Information
- List of References
- List of Subcontractors
- Certificate of Secretary of Adoption of Resolution
- List of Subcontractors, Suppliers, & Vendors Contacted to Receive Prices in Preparation of Bid Proposal
- Non-Collusion Affidavit

CONTRACTOR'S PROPOSAL

CITY OF SAN FERNANDO
117 MACNEIL STREET
SAN FERNANDO, CALIFORNIA 91340

HONORABLE MAYOR AND
MEMBERS OF THE CITY COUNCIL:

The undersigned declares that this proposal was prepared by carefully examining the location of the proposed work, the Plans, the Specifications, and the Contract Documents entitled:

**FOG SEAL COATING AND STRIPING OF CITY PARKING LOTS
JOB NO. 7627**

The undersigned hereby proposes to furnish all labor, materials, notifications, equipment, tools, transportation, and services to perform all work required and to complete said work within **forty-five (45)** working days after the commencement date stated in the Notice to Proceed. All work shall be performed in accordance with the Plans, Specifications, and Contract Documents, including the Special Provisions and Technical Provisions, for the prices set forth in the bid schedule.

Dated

Bidder

Signature

Name (Print/Type)

Title

BID SCHEDULE
FOG SEAL COATING AND STRIPING OF CITY PARKING LOTS
JOB NO. 7627

PARKING LOT 3					
ITEM NO.	DESCRIPTION	UNIT	ESTIMATED QUANTITY	UNIT PRICE	ITEM TOTAL
1.	PROVIDE TRAFFIC CONTROL	LS	1	\$	\$
2.	MOBILIZATION	LS	1	\$	\$
3.	CRACKSEALING	LS	1	\$	\$
4.	FOG SEALING	SY	6,255	\$	\$
5.	REMOVE AND REPLACE ASPHALT	SF	1,500	\$	\$
6.	STRIPING AND PAVEMENT MARKINGS	LS	1	\$	\$
SUBTOTAL ITEMS 1-5					\$

PARKING LOT 4					
ITEM NO.	DESCRIPTION	UNIT	ESTIMATED QUANTITY	UNIT PRICE	ITEM TOTAL
1.	MOBILIZATION	LS	1	\$	\$
2.	CRACKSEALING	LS	1	\$	\$
3.	FOG SEALING	SY	4,305	\$	\$
4.	STRIPING AND PAVEMENT MARKINGS	LS	1	\$	\$
SUBTOTAL ITEMS 1-4					\$

PARKING LOT 5					
ITEM NO.	DESCRIPTION	UNIT	ESTIMATED QUANTITY	UNIT PRICE	ITEM TOTAL
1.	MOBILIZATION	LS	1	\$	\$
2.	CRACKSEALING	LS	1	\$	\$
3.	FOG SEALING	SY	2,455	\$	\$
4.	STRIPING AND PAVEMENT MARKINGS	LS	1	\$	\$
SUBTOTAL ITEMS 1-4					\$

PARKING LOT 6N					
ITEM NO.	DESCRIPTION	UNIT	ESTIMATED QUANTITY	UNIT PRICE	ITEM TOTAL
1.	MOBILIZATION	LS	1	\$	\$
2.	CRACKSEALING	LS	1	\$	\$
3.	FOG SEALING	SY	4,450	\$	\$
4.	STRIPING AND PAVEMENT MARKINGS	LS	1	\$	\$
SUBTOTAL ITEMS 1-4					\$

PARKING LOT 7					
ITEM NO.	DESCRIPTION	UNIT	ESTIMATED QUANTITY	UNIT PRICE	ITEM TOTAL
1.	PROVIDE TRAFFIC CONTROL	LS	1	\$	\$
2.	MOBILIZATION	LS	1	\$	\$
3.	CRACKSEALING	LS	1	\$	\$
4.	FOG SEALING	SY	670	\$	\$
5.	STRIPING AND PAVEMENT MARKINGS	LS	1	\$	\$
SUBTOTAL ITEMS 1-5					\$

PARKING LOT 8					
ITEM NO.	DESCRIPTION	UNIT	ESTIMATED QUANTITY	UNIT PRICE	ITEM TOTAL
1.	PROVIDE TRAFFIC CONTROL	LS	1	\$	\$
2.	MOBILIZATION	LS	1	\$	\$
3.	CRACKSEALING	LS	1	\$	\$
4.	FOG SEALING	SY	4,425	\$	\$
5.	REMOVE AND REPLACE AC	SF	3,000	\$	\$
6.	STRIPING AND PAVEMENT MARKINGS	LS	1	\$	\$
SUBTOTAL ITEMS 1-5					\$

PARKING LOT 9					
ITEM NO.	DESCRIPTION	UNIT	ESTIMATED QUANTITY	UNIT PRICE	ITEM TOTAL
1.	MOBILIZATION	LS	1	\$	\$
2.	CRACKSEALING	LS	1	\$	\$
3.	FOG SEALING	SY	2,045	\$	\$
4.	REMOVE AND REPLACE ASPHALT	SF	1,500	\$	\$
5.	STRIPING AND PAVEMENT MARKINGS	LS	1	\$	\$
SUBTOTAL ITEMS 1-4					\$

PARKING LOT 10					
ITEM NO.	DESCRIPTION	UNIT	ESTIMATED QUANTITY	UNIT PRICE	ITEM TOTAL
1.	MOBILIZATION	LS	1	\$	\$
2.	CRACKSEALING	LS	1	\$	\$
3.	FOG SEALING	SY	1,725	\$	\$
4.	REMOVE AND REPLACE ASPHALT	SF	2,000	\$	\$
5.	COOL PAVEMENT (BID ALTERNATE)	SF	16,500	\$	\$
6.	STRIPING AND PAVEMENT MARKINGS	LS	1	\$	\$
SUBTOTAL ITEMS 1-4					\$

CITY HALL PARKING LOT					
ITEM NO.	DESCRIPTION	UNIT	ESTIMATED QUANTITY	UNIT PRICE	ITEM TOTAL
1.	MOBILIZATION	LS	1	\$	\$
2.	CRACKSEALING	LS	1	\$	\$
3.	FOG SEALING	SY	1,600	\$	\$
4.	STRIPING AND PAVEMENT MARKINGS	LS	1	\$	\$
SUBTOTAL ITEMS 1-4					\$

POLICE PARKING LOT					
ITEM NO.	DESCRIPTION	UNIT	ESTIMATED QUANTITY	UNIT PRICE	ITEM TOTAL
1.	MOBILIZATION	LS	1	\$	\$
2.	CRACKSEALING	LS	1	\$	\$
3.	FOG SEALING	SY	2,350	\$	\$
4.	STRIPING AND PAVEMENT MARKINGS	LS	1	\$	\$
SUBTOTAL ITEMS 1-4					\$

The bidder acknowledges receipt of the following addendum issued for the above project. If no addendum has been received, write "None".

List of Addendum Received: _____

The City does not expressly or by implication agree that the actual amount of work will correspond with the foregoing quantities, but reserves the right to increase or decrease the amount of any class or portion of the work or to omit portions of the work as may be deemed necessary or advisable by the Engineer.

The bidder further agrees that in case of not executing the required contract with necessary bonds within ten (10) days, not including Sundays, after having received notice that the contract is ready for signature, the proceeds of the check or bond accompanying his bid shall become the property of the City of San Fernando.

By submission of the Contractor's Proposal, the bidder also certifies that the bid is a balanced bid.

BIDDER'S BOND

KNOW ALL MEN BY THESE PRESENTS:

that we, _____ as Principal,
and _____ as Surety,
are held and firmly bound unto the City of San Fernando in the sum of _____
_____ (\$ _____)
to be paid to the said City of its certain Attorney, its successors and assigns; for the payment of
which sum well and truly made, we bind ourselves, our heirs, executors and administrators,
successors or assigns, jointly and severally, firmly by these presents.

THE CONDITION OF THIS OBLIGATION IS SUCH, that if the certain proposal of the above
bounden _____
to construct _____
(insert names of streets and limits to be improved) dated _____ is accepted by
the City of San Fernando, and if the above bounden his heirs, executors, administrators, successors
and assigns, shall duly enter into and execute a contract for such construction, and shall execute
and deliver the two bonds described within ten (10) days (not including Sunday) from the date of
the mailing of a notice to the above bounden _____
by and from the said City of San Fernando that said contract is ready for execution, then this
obligation shall become null and void; otherwise it shall be and remain in full force and virtue.

IN WITNESS WHEREOF, we hereunto set our hands and seals this _____ day of
_____, 2024.

Principal	Surety
By _____	By _____
Its _____	Its _____
By _____	By _____
Its _____	Its _____

Surety signatures on this bond must be acknowledged before Notary Publics, and a sufficiently
power of attorney must be attached to the bond to verify the authority of any party signing on
behalf of a surety.

All notices and demands to the surety shall be delivered via first class mail to the following:

CONTRACTOR INFORMATION

Company Name _____

Address _____

Telephone _____ Fax _____ E-mail _____

Type of Firm: Individual () Partnership () Corporation ()

Corporation organized under the laws of the State of _____

Contractor's License Number _____ State ____ Classification _____ Expiration Date _____

DIR Registration Number _____ Expiration Date _____

Names and titles of all officers of the firm

LIST OF REFERENCES

(To be submitted by contractors who have not worked with the City of San Fernando.)

1. NAME OF CITY OR BUSINESS _____
 CONTACT PERSON AND PHONE NO. _____
 TYPE/DATE OF WORK PERFORMED _____
 TOTAL CONTRACT AMOUNT \$ _____

2. NAME OF CITY OR BUSINESS _____
 CONTACT PERSON AND PHONE NO. _____
 TYPE/DATE OF WORK PERFORMED _____
 TOTAL CONTRACT AMOUNT \$ _____

3. NAME OF CITY OR BUSINESS _____
 CONTACT PERSON AND PHONE NO. _____
 TYPE/DATE OF WORK PERFORMED _____
 TOTAL CONTRACT AMOUNT \$ _____

4. NAME OF CITY OR BUSINESS _____
 CONTACT PERSON AND PHONE NO. _____
 TYPE/DATE OF WORK PERFORMED _____
 TOTAL CONTRACT AMOUNT \$ _____

5. NAME OF CITY OR BUSINESS _____
 CONTACT PERSON AND PHONE NO. _____
 TYPE/DATE OF WORK PERFORMED _____
 TOTAL CONTRACT AMOUNT \$ _____

6. NAME OF CITY OR BUSINESS _____
 CONTACT PERSON AND PHONE NO. _____
 TYPE/DATE OF WORK PERFORMED _____
 TOTAL CONTRACT AMOUNT \$ _____

LIST OF SUBCONTRACTORS

The bidder is required to fill in the following blanks in accordance with the provisions of Section 4100 to 4108, inclusive, of the Government Code of the State of California.

Name under which subcontractor is licensed: _____

Address of office, mill or shop: _____

Specific description of subcontract: _____

License No.: _____ Amount of Subcontract: _____

DIR Registration Number: _____ Expiration Date: _____

Name under which subcontractor is licensed: _____

Address of office, mill or shop: _____

Specific description of subcontract: _____

License No.: _____ Amount of Subcontract: _____

DIR Registration Number: _____ Expiration Date: _____

Name under which subcontractor is licensed: _____

Address of office, mill or shop: _____

Specific description of subcontract: _____

License No.: _____ Amount of Subcontract: _____

DIR Registration Number: _____ Expiration Date: _____

Name under which subcontractor is licensed: _____

Address of office, mill or shop: _____

Specific description of subcontract: _____

License No.: _____ Amount of Subcontract: _____

DIR Registration Number: _____ Expiration Date: _____

**CERTIFICATE OF SECRETARY
OF ADOPTION OF RESOLUTION**

I, _____(insert name of Secretary), do hereby certify that I am the Secretary of _____(insert name of corporation) a California corporation, and do hereby certify that the following resolution is a full, true and correct copy of a resolution passed by the Board of Directors of said corporation at a meeting thereof held on the _____ day of _____, 2024 (insert proper date), in accordance with the bylaws of said corporation, and that said resolution has not to the date of this certificate been in any manner amended, modified, revoked, rescinded or annulled, and the same is now in full force and effect.

“RESOLVED, that any of the following officers of this corporation, _____, _____ President _____, Vice President and _____, secretary *(insert names of officers and capacity where not shown), (any two acting together) (any one acting alone) (strike out inapplicable portion)*, be and they are hereby authorized to execute and deliver in the name of and for and on behalf of this corporation, any and all bids, authorizations, contracts, bonds and agreements of any nature or sort whatsoever.

BE IT FURTHER RESOLVED, that any and all persons, firms, corporations and other entities, including public entities, shall be entitled to rely on the authority of (any one of such officers) (any two of such officers acting together) (strike out inapplicable portion), above named, to bind this corporation by the execution and delivery of any such bids, authorizations, contracts, bonds and agreements.

BE IT FURTHER RESOLVED, that the authority herein contained shall remain effective until the person, corporation, or public entity relying upon the authority herein contained, receives written notice to the contrary signed by duly authorized officers of this corporation, that all previous authorizations theretofore given with respect to the matters herein contained are revoked. That the revocation of the authority herein contained shall not affect the validity of any instrument herein referred to signed by any person or persons at the time authorized to act.”

IN WITNESS WHEREOF, the undersigned has hereunto set (his/her) hand as Secretary and affixed the seal of this corporation this _____ day of _____, 2024.

Secretary

Affix Seal

**LIST OF SUBCONTRACTORS, SUPPLIERS, & VENDORS CONTACTED TO
RECEIVE PRICES IN PREPARATION OF BID PROPOSAL**

1. NAME & LOCATION OF BUSINESS _____

CONTACT PERSON AND PHONE NO. _____
ITEM OR TYPE OF WORK PROPOSED _____
PRICE OR AMOUNT \$ _____
2. NAME & LOCATION OF BUSINESS _____

CONTACT PERSON AND PHONE NO. _____
ITEM OR TYPE OF WORK PROPOSED _____
PRICE OR AMOUNT \$ _____
3. NAME & LOCATION OF BUSINESS _____

CONTACT PERSON AND PHONE NO. _____
ITEM OR TYPE OF WORK PROPOSED _____
PRICE OR AMOUNT \$ _____
4. NAME & LOCATION OF BUSINESS _____

CONTACT PERSON AND PHONE NO. _____
ITEM OR TYPE OF WORK PROPOSED _____
PRICE OR AMOUNT \$ _____
5. NAME & LOCATION OF BUSINESS _____

CONTACT PERSON AND PHONE NO. _____
ITEM OR TYPE OF WORK PROPOSED _____
PRICE OR AMOUNT \$ _____
6. NAME & LOCATION OF BUSINESS _____

CONTACT PERSON AND PHONE NO. _____
ITEM OR TYPE OF WORK PROPOSED _____
PRICE OR AMOUNT \$ _____

NON-COLLUSION AFFIDAVIT

FOG SEAL COATING AND STRIPING OF CITY PARKING LOTS
JOB NO. 7627

STATE OF CALIFORNIA)
) SS
COUNTY OF _____)

_____, being first duly sworn, deposes and
says that he is _____
(Sole owner, partner, president, secretary, etc.)

of _____
the party making the foregoing bid; that such bid is not made in the interest of or on behalf of any undisclosed person, partnership, company, association, organization or corporation; that such bid is genuine and not collusive or sham; that such bidder has not directly or indirectly colluded, conspired, connived or agreed with any bidder or anyone else to put in a sham bid, or that anyone shall refrain from bidding; that said bidder has not in any manner, directly or indirectly, sought by agreement, communication or conference with anyone to fix the bid price of said bidder or of any other bidder, or to fix any overhead, profit or cost element of such bid price, or of that of any other bidder, or to secure an advantage against the public body awarding the contract or anyone interested in the proposed contract; that all statements contained in such bid price or of that of any other bidder, or to secure an advantage against the public body awarding the contract or anyone interested in the proposed contract; that all statements contained in such bid are true; and, further, that said bidder has not, directly or indirectly, submitted his bid price or any breakdown thereof, or the contents thereof, or divulged information or data relative thereto, or paid and will not pay any fee in connection therewith to any corporation, partnership, company, association, organization, bid depository, or to any member or agent thereof, or to any other individual except to such person or persons as have a partnership or other financial interest with said bidder in his general business.

Date

Bidder

Authorized Signature

STATE OF CALIFORNIA)
) SS
COUNTY OF _____)

Name (Print/Type)

Title

On _____, 2024 before me, _____

Personally appeared _____ who proved to me on the basis of satisfactory evidence to be the person(s) whose name(s) is/are subscribed to the within instrument and acknowledge to me that he/she/they executed the same in his/her/their authorized capacity(ies), and that by his/her/their signature(s) on the instrument, the person(s) or the entity upon behalf of which the person(s) acted, executed the instrument.

I certify under PENALTY OF PERJURY under the laws of the State of California that the foregoing paragraph is true and correct.

(Notary Seal)

Signature of Notary Public



CONSTRUCTION CONTRACT/AGREEMENT

**FOG SEAL COATING AND STRIPING OF CITY PARKING LOTS
JOB NO. 7627**

THIS AGREEMENT, made and entered into this ___ day of _____ 2024, by and between CITY OF SAN FERNANDO, a municipal corporation of the State of California, hereinafter referred to as "CITY" and _____ "CONTRACTOR."

WITNESSETH:

That the CITY and the CONTRACTOR, for the consideration hereinafter named, mutually agree as follows:

1. The complete contract consists of the Contract Documents which includes all of the following documents incorporated herein by this reference: Approved **FOG SEAL COATING AND STRIPING OF CITY PARKING LOTS JOB NO. 7627**, Notice Inviting Bids, Instructions to Bidders, Contractor's Proposal, Contract/Agreement, Special Provisions, Technical Provisions, and all modifications and amendments thereto.

2. CONTRACTOR shall perform everything required to be performed, shall provide and furnish all the labor, materials, necessary tools, expendable equipment, and all utility and transportation services required for the following work of improvement: **FOG SEAL COATING AND STRIPING OF CITY PARKING LOTS JOB NO. 76xx**, (the "Work of Improvement") all in accordance with the Contract Documents and Contractor's Proposal dated _____, 2024.

CONTRACTOR agrees to perform all the work and furnish all the materials at his own cost and expense necessary to construct and complete in a good and workman-like manner and to the satisfaction of the City Engineer of the CITY, the Work of Improvement in accordance with the plans, specifications, and Contract Documents (the "Specifications") therefore prepared by City's Engineering Department and adopted by the City Council.

3. CITY agrees to pay and CONTRACTOR agrees to accept in full payment for this Work of Improvement the stipulated sum of _____ (\$_____).

CITY agrees to make monthly payments and final payment in accordance with the method set forth in the Specifications.

4. CONTRACTOR agrees to commence construction of the Work of Improvement within ten (10) days after issuance of a Notice To Proceed, and to continue in a diligent and workman-like manner without interruption, and to complete the construction thereof within forty-five (45) working

days.

5. Time is of essence of this Contract, and it is agreed that it would be impracticable or extremely difficult to ascertain the extent of actual loss or damage which the CITY will sustain by reason of any delay in the performance of this Agreement. It is, therefore, agreed that CONTRACTOR will pay as liquidated damages to the CITY the following sum: One Thousand Dollars (\$1000.00) for each day's delay beyond the time herein prescribed for finishing work. If liquidated damages are not paid, as designated by the CITY, the CITY may deduct the amount thereof from any money due or that may become due the CONTRACTOR under this Agreement in addition to any other remedy available to CITY. The CONTRACTOR shall not be assessed liquidated damages for any delay caused by the failure of a public utility to relocate or remove an existing utility required for the performance of this Contract.

6. The CONTRACTOR will pay, and will require all subcontractors to pay, all employees on the work of improvement a salary or wage at least equal to the prevailing salary or wage established for such work as set forth in the wage determinations for this work. Travel and subsistence pay shall be paid in accordance with Labor Code Section 1773.8. The CONTRACTOR shall forfeit to the CITY, as penalty, Fifty Dollars (\$50.00) for each calendar day or portion thereof for each worker paid (either by him or any subcontractors under him) less than the prevailing rate described above on the work provided for in this Agreement, all in accordance with Section 1775 of the Labor Code of the State of California.

7. In the performance of this Contract, not more than eight (8) hours shall constitute a day's work, and the CONTRACTOR shall not require more than eight (8) hours in a day from any person employed by him hereunder, except as provided in the Labor Code of the State of California. The CONTRACTOR shall adhere to Article 3, Chapter 1, Part 7 (Sections 1810, et seq.) of the Labor Code of the State of California, and it is agreed that the CONTRACTOR shall forfeit to the CITY as a penalty the sum of Twenty-five Dollars (\$25.00) for each worker employed in the execution of this Contract by the CONTRACTOR or any subcontractor for each calendar day during which any worker is required or permitted to labor more than eight (8) hours in violation of that article.

8. CONTRACTOR, by executing this Agreement hereby certifies:
"I am aware of the provisions of Section 3700 of the Labor Code which requires every employer to be insured against liability for Worker's Compensation or to undertake self-insurance in accordance with the provisions of that Code, and I will comply with such provisions before commencing the performance of the work of this Contract."

9. CONTRACTOR shall, prior to the execution of this Contract, furnish two bonds approved by the CITY, one in the amount of One Hundred Percent (100%) of the Contract price, to guarantee the faithful performance of the work, and one in the amount of One Hundred Percent (100%) of the Contract price to guarantee payment of all claims for labor and materials furnished. This Contract shall not become effective until such bonds are supplied to and approved by the CITY. CONTRACTOR shall, prior to the release of the performance and payment bonds or the retention payment, furnish a warranty performance and payment bond equal to at least ten percent of the final contract price or \$1,000, whichever is greater.

CONSTRUCTION CONTRACT/AGREEMENT

Fog Seal Coating And Striping Of City Parking Lots JOB NO. 7627

Page 3 of 3

IN WITNESS WHEREOF, the said CONTRACTOR and the CITY ADMINISTRATOR and CITY CLERK of the CITY have caused the names of said parties to be affixed hereto, each in triplicate, the day and year first above written.

CONTRACTOR

BY _____

Title

BY _____

Title

CITY OF SAN FERNANDO
A Municipal Corporation

NICK KIMBALL

CITY MANAGER

ATTEST:

JULIA FRITZ
CITY CLERK

APPROVED AS TO FORM:

RICK R. OLIVAREZ
CITY ATTORNEY
OLIVAREZ MADRUGA, P.C.

PERFORMANCE BOND

KNOW ALL MEN BY THESE PRESENTS: that we, _____
as Principal, and _____ as Surety,
are held and firmly bound unto the CITY OF SAN FERNANDO, hereinafter called the Owner,
in the sum of _____ (\$ _____)
for the payment of which sum well and truly to be made, we bind ourselves, our heirs,
executors, administrators and successors, jointly and severally, firmly by these presents.

The conditions of this obligation are such that whereas the Principal entered into a
contract, attached hereto, with the Owner dated _____ for _____
_____.

NOW, THEREFORE, if the principal shall well and truly perform and fulfill all the
undertakings, covenants, terms, conditions and agreements of said contract during the
original term thereof, and any extensions thereof that may be granted by the Owner with
or without notice of the Surety, and during the life of any guaranty required under the
contract, and shall also well and truly perform and fulfill all the undertakings, covenants,
terms, conditions and agreements of any and all duly authorized modifications of said
contract that may hereafter be made, then this obligation shall be void; otherwise this
obligation shall remain in full force and virtue.

Further, the said Surety, for value received, hereby stipulates and agrees that no change,
extension of time, alteration or modification of the contract documents or of the work to be
performed thereunder shall in any way affect its obligations on this bond; and it hereby
waives notice of any and all such changes, extensions of time; and alterations or
modifications of the contract documents and/or of the work to be performed thereunder.
IN WITNESS WHEREOF, the above bounden parties have executed this instrument under
their several seals the _____ day of _____, 2024, the name and
corporate seal of each corporate party being hereto affixed and these presents duly signed
by each party's undersigned representative, pursuant to authority of its governing body.

(Principal)

ATTEST:

(Address)

(By)

(Title)

(Surety)

ATTEST:

(Address)

(By)

(Title)

(To be filled in by Surety)

Rate of premium on this bond is \$_____ per thousand.

Total amount of premium charge is \$_____.

Surety signatures on this bond must be acknowledged before Notary Publics, and a sufficiently power of attorney must be attached to the bond to verify the authority of any party signing on behalf of a surety.

All notices and demands to the surety shall be delivered via first class mail to the following:

PAYMENT (LABOR AND MATERIAL) BOND

KNOW ALL MEN BY THESE PRESENTS: that we, _____
as Principal, and _____ as Surety,
are held and firmly bound unto the CITY OF SAN FERNANDO, hereinafter called the Owner,
in the sum of _____ (\$ _____)
for the payment of which sum well and truly to be made, we bind ourselves, our heirs,
executors, administrators and successors, jointly and severally, firmly by these presents.

The conditions of this obligation are such that whereas the Principal entered into a
contract, attached hereto, with the Owner dated _____ for _____
_____.

NOW, THEREFORE, if the Principal shall promptly make payment to all persons supplying
labor and material in the prosecution of the work provided for in said contract, and any and
all duly authorized modifications of each contract that may hereafter be made, then this
obligation shall be void, otherwise this obligation shall remain in full force and virtue.

The condition of this obligation is such that, if said Principal or his or its subcontractors, or
the heirs, executors, administrators, successors or assigns thereof, shall fail to pay any of
the persons named in Section 3181 of the Civil Code of the State of California for any
materials, provisions, provender or other supplies used in, upon, for or about the
performance of the work or labor performed by any such claimant or any amounts required
to be deducted, withheld, and paid over to the Franchise Tax Board from the wages of
employees of the contractor and his subcontractors pursuant to Section 18806 of the
Revenue and Taxation Code, with respect to such work and labor, then said Surety will pay
for the same, in the amount not exceeding the sum set forth hereinabove and also, in case
suit is brought upon the bond, will pay a reasonable attorney's fee to be fixed by the court.

This bond shall insure to the benefit of any and all persons named in the aforesaid Civil
Code Section 3131 so as to give a right of action to them or their assigns in any suit
brought upon the bond.

Further, the said Surety, for value received, hereby stipulates and agrees that no change,
extension of time, alteration or modification of the contract documents or of the work to be
performed thereunder shall in any way affect its obligations on this bond; and it hereby
waives notice of any and all such changes, extensions of time; and alterations or
modifications of the contract documents and/or of the work to be performed thereunder.

IN WITNESS WHEREOF, the above bounden parties have executed this instrument under their several seals the _____ day of _____, 2024, the name and corporate seal of each corporate party being hereto affixed and these presents duly signed by each party's undersigned representative, pursuant to authority of its governing body.

(Principal)

ATTEST:

(Address)

(By)

(Title)

(Surety)

ATTEST:

(Address)

(By)

(Title)

(To be filled in by Surety)

Rate of premium on this bond is \$ _____ per thousand.

Total amount of premium charge is \$ _____.

Surety signatures on this bond must be acknowledged before Notary Publics, and a sufficiently power of attorney must be attached to the bond to verify the authority of any party signing on behalf of a surety.

All notices and demands to the surety shall be delivered via first class mail to the following:

WARRANTY PERFORMANCE AND PAYMENT BOND

KNOW ALL MEN BY THESE PRESENTS: that _____ as Principal, hereinafter called Contractor, and _____, licensed and domiciled in the state of California as Surety, hereinafter called Surety, are held and firmly bound unto CITY OF SAN FERNANDO as Obligee, hereinafter called Owner, in the amount of _____ (\$ _____) for the payment whereof Contractor and Surety bind themselves, their heirs, executors, administrators, successors and assigns, jointly and severally, firmly by these presents.

WHEREAS, _____ as Contractor, has by written agreement dated _____, 2024, entered into a contract with Owner for FOG SEAL COATING AND STRIPING OF CITY PARKING LOTS, JOB NO. 7627 in accordance with Drawings and Specifications contained in a written and executed contract, which contract is by reference made a part hereof, and is hereinafter referred to as the Contract.

WHEREAS, said contract provides that the Principal shall furnish a bond which shall remain in force for a period of **one** year after the date of the notice of completion and which shall be conditioned to guarantee against all defects in workmanship and materials which shall become apparent during said period.

NOW THEREFORE, the condition of this obligation is such that, if Contractor shall promptly and faithfully perform said Contract, then this obligation shall be null and void; otherwise it shall remain in full force and effect.

The Surety hereby waives notices of any alteration or extension of time made by the Owner.

Whenever Contractor shall be, and declared by Owner to be in default under the Contract, the Owner having performed Owner's obligations thereunder, the Surety may promptly remedy the default, or shall promptly:

- (1) Complete the Contract in accordance with its terms and conditions, or;
- (2) Obtain a bid or bids for completing the Contract in accordance with its terms and conditions, and upon determination by Surety of the lowest responsible bidder, arrange for a contract between such bidder and Owner, and make available as work progresses (even though there should be a default or a succession of defaults under the contract or contracts of completion arranged under this paragraph) sufficient funds to pay the cost of completion less the balance of the contract price, but not exceeding, including other costs and damages for which the Surety may be liable hereunder, the amount set forth in the first paragraph hereof. The term "balance of the contract price," as used in this paragraph, shall mean the total amount payable by Owner to Contractor under the Contract and any amendments thereto, less the amount properly paid by Owner to Contractor.

The transaction of insurance as evidenced by this bond is agreed by all parties to have taken place in the State of California in conformance with the laws therein, the Surety hereby accepts jurisdiction for adjudication of all claims in the state wherein the claims have occurred.

This bond is for the protection of the owner and gives no protection to any claimant other than those provided for by statute in the state wherein the claim occurs. The owner hereby agrees that no payments shall be made in excess or advance of any work specifically performed under the contract without the express written consent of the Surety.

For claims regarding non-payment for services provided or materials supplied under the contract, a claimant is defined herein as one having a direct contract with the Principal and/or subcontractor of the Principal. No suit or action shall be commenced hereunder by any claimant unless claimant shall:

1. Notify the Surety of the direct contract with the Principal or Subcontractor of the Principal within 30 days of entering into such contract and;

2. Notify the Surety of any demands for payment under such direct contracts concurrently with the Principal and/or Subcontractor of the Principal and;
3. Notify the Surety by certified mail within 15 days of any payment not made when due, or within 30 days of demand.

As the purpose of this bond is to warrant work previously performed by the Principal in the contract specified herein, the Owner shall notify Surety immediately by certified mail upon demand for work to be performed under this bond.

IN WITNESS WHEREOF, the above bounden parties have executed this instrument under their several seals the _____ day of _____, 2024, the name and corporate seal of each corporate party being hereto affixed and these presents duly signed by each party's undersigned representative, pursuant to authority of its governing body.

(Principal)

ATTEST:

(Address)

(By)

(Title)

(Surety)

ATTEST:

(Address)

(By)

(Title)

(To be filled in by Surety)

Rate of premium on this bond is \$ _____ per thousand.

Total amount of premium charge is \$ _____.

Surety signatures on this bond must be acknowledged before Notary Publics, and a sufficiently power of attorney must be attached to the bond to verify the authority of any party signing on behalf of a surety.

All notices and demands to the surety shall be delivered via first class mail to the following:

GENERAL PROVISIONS

PART I

The documents that control construction, work performed, and materials furnished hereunder are the Contract Documents. The Contract Documents include the Notice Inviting Bids, Contractor's Proposal, Contract/Agreement, Bonds, Specifications, and the documents in the Appendix, if any, all of which are hereby incorporated and made a part of these Contract Documents. The Specifications include the Standard Specifications, these Special Provisions which supplement or modify the Standard Specifications, Plans, Standard Plans, and the Technical Specifications.

STANDARD SPECIFICATIONS

The Standard Specifications is the latest edition of the Standard Specifications for Public Works Construction (SSPWC or "Greenbook"), including supplements, written and promulgated by the Southern California Chapter of the American Public Works Association and the Southern California Districts of the Associated General Contractors of California, and the American Water Works Association (AWWA) Standards.

In case of conflict between documents, the precedence of documents shall follow Subsection 3-7.2 of the Standard Specifications, except that the Technical Provisions precede the Special Provisions. However, for any other precedence of documents, the Technical Provisions shall be considered part of the Special Provisions.

For the convenience of the Contractor, the section and subsection numbering system used in these Special Provisions corresponds to that used in the Standard Specifications.

SECTION 1 - TERMS, DEFINITIONS, ABBREVIATIONS, AND SYMBOLS

Subsection 1-2 Terms and Definitions

Add the following to the provisions of Subsection 1-2, "Terms and Definitions":

The Standard Specifications, Standard Plans, and Manual of Traffic Controls, latest edition of each, of the State of California, Department of Transportation, and the Los Angeles County Department of Public Works Standard Plans, the City of San Fernando Standard Plans, and the American Water Works Association (AWWA) are incorporated herein by reference and are hereby accepted as Reference Specifications. These Reference Specifications are intended to govern certain construction materials, methods, and details except as modified herein or are inconsistent with the provisions herein. In case of conflict between the Reference Specifications and the Technical Provisions, the Technical Provisions shall govern. In case of a conflict between drawings and Technical Provisions, Technical Provisions shall prevail.

Subsection 1-7 Award and Execution of the Contract

Add the following to the provisions of Subsection 1-7, "Award and Execution of the Contract":

By mutual consent in writing of the parties signatory to the contract, alterations or deviations, increase or decreases, additions or omissions, in the plans and specifications may be made and the same shall in no way affect or make void the contract.

Add the following to the provisions of Subsection 1-7.2, "Contract Bonds":

The performance bond shall remain in effect at least until the date of substantial completion/notice of completion, except as otherwise provided. The contractor warrants and guarantees to the City that all work will not be defective. The contractor shall furnish a warranty performance and payment bond equal to at least one hundred percent of the final contract price or \$1,000, whichever is greater, before the contract performance and payment bonds can be released or the retention payment paid. The warranty performance and payment bond shall be in effect until at least one year after the date of the notice of completion, except that utility work shall require it to be in effect for three years.

SECTION 2 - SCOPE OF THE WORK

Subsection 2-2 Permits

Add the following to the provisions of Subsection 2-2, "Permits":

The Contractor shall procure all permits and licenses, pay all charges and fees, and give all notices necessary and incidental to the due and lawful prosecution of the work

Pursuant to State Bill 854, the following new requirements apply to all public works projects:

A contractor or subcontractor shall not be qualified to bid on, be listed in a bid proposal, subject to the requirements of Section 4104 of the Public Contract Code, or engage in the performance of any contract for public work, as defined in this chapter, unless currently registered and qualified to perform public work pursuant to Section 1725.5. It is not a violation of this section for an unregistered contractor to submit a bid that is authorized by Section 7029.1 of the Business and Professions Code or by Section 10164 or 20103.5 of the Public Contract Code, provided the contractor is registered to perform public work pursuant to Section 1725.5 at the time the contract is awarded. The website for contractor registration with the Department of Industrial Relations (DIR) is <https://efiling.dir.ca.gov/PWCR>; the annual non-refundable fee, valid July 1 through June 30 (state fiscal year), is \$300.

Contractors who are awarded a public works project must submit electronic payroll records to the DIR's Compliance Monitoring Unit (CMU) in addition to providing wet-ink original copies to the City or its designated labor compliance enforcement officer.

Subsection 2-8 Extra Work

Add the following to the provisions of Subsection 2-8, "Extra Work":

Change Order (C/O) requests must be on company letterhead and within the letter provide detailed information for what C/O consists of and what triggered C/O.

All C/O requests, even if still within contingency, needs to be submitted to City in manner stated above. Additionally, no work related to C/O can be done until letter request has been received by City and funds available to cover C/O have been confirmed.

When extra work is determined to be warranted by the Contractor, due to any type of problems, such as changed conditions, plan interpretations, progress billing, or others, the following procedure shall be followed:

- 1) The Contractor shall notify the inspector and follow up in writing to the Engineer
- 2) Inspector informs the Engineer, and Engineer investigates the matter
- 3) Engineer reviews and submits findings to the City Engineering, including recommendations for approving/denying Contractor's request
- 4) Engineer notifies Contractor with the City decision in writing.

The contractor shall proceed with extra work only upon written order from the Engineer. For such extra work the contractor shall receive payment as agreed upon in writing, or he shall be paid on force account. The contractor shall not exceed any of the quantities in the proposal unless prior authorization from the engineer is obtained in writing.

The Contractor shall notify in writing the Engineer within three (3) working days following the discovery of potential extra work or change order. Failing to notify the Engineer within the time required shall constitute a waiver of any potential change order.

Subsection 2-9 Changed Conditions

The Contractor's failure to provide written notice of changed conditions within 48 hours upon their discovery to the Engineer and before they are disturbed shall constitute a waiver of compensation and claims in connection therewith.

The contractor shall proceed with extra work only upon written order from the Engineer. For such extra work the contractor shall receive payment as agreed upon in writing, or he shall be paid on force account. The contractor shall not exceed any of the quantities in the proposal unless prior authorization from the engineer is obtained in writing.

Subsection 2-10 Disputed Work

Add the following to the provisions of Subsection 2-10, "Disputed Work":

- A. In accordance with Public Contract Code Section 20104, and for the purposes of Paragraphs B only, the term "Defined Claim" shall mean a separate demand by the Contractor to the Owner of a value of \$375,000 or less, for any of the following: (a) a time extension, (b) payment of money or damages arising from work done by the Contractor pursuant to the Contract Documents and payment of which is not otherwise expressly provided for or the Contractor is not otherwise entitled to, or (c) an amount of payment which is disputed by the Owner.
- B. RESOLUTION OF DEFINED CLAIMS Pursuant to Sections 20104 et seq., of the Public Contracts Code, the provisions of this Paragraph B shall apply to all "Defined Claims," as such term is defined in Paragraph A (i.e., claims that are in the amount of \$375,000 or less).

Filing and Response to Defined Claim

The Defined Claim shall be in writing, include the documents necessary to substantiate the Defined Claim, and be filed with the Owner on or before the date of the final payment for the work.

If the Defined Claim is less than \$50,000, the new Owner shall respond in writing to the Defined Claim within 45 days of its receipt; or the Owner may request in writing within 30 days of receipt of the Defined Claim any additional documentation supporting the Defined Claim or relating to defenses or claims the Owner may have against the Contractor, and in such event the Owner's response shall be submitted to the Contractor within the later of 15 days after the receipt of the further documentation, or the time taken by the Contractor in producing the additional information.

If the Defined Claim is over \$50,000, the Owner shall respond in writing to the Defined Claim within 60 days of its receipt, or the Owner may request in writing within 30 days of receipt of the Defined Claim any additional documentation supporting the Defined Claim or relating to defenses or claims the Owner may have against the Contractor, and in such event the Owner's response shall be submitted to the Contractor within the later of 30 days after the receipt of the further documentation, or the time taken by the Contractor in producing the additional information or requested documentation.

Meet and Confer Regarding Defined Claim

If the Contractor disputes the Owner's written response, or if the Owner fails to respond within the prescribed time, to the Defined Claim, the Contractor may notify the Owner in writing within 15 days, and demand an informal conference to meet and confer for settlement of the issues in dispute. Upon receipt of the demand, the Owner shall schedule a meet and confer conference within 30 days. If the claim or any portion thereof remains in dispute following the meet and confer conference, the Contractor may file a claim pursuant to Government Code Section 900, et seq. For purposes of this Paragraph B, the running of the period of time within which a claim must be filed shall be tolled from the time the Contractor submits the Defined Claim until the time such Defined Claim is denied, including any period of time utilized by the meet and confer conference.

Procedures for Civil Actions Filed to Resolve Defined Claims

The following procedures shall apply to any civil action filed pursuant to this Paragraph B:

Non-Binding Mediation Within 60 days, but no earlier than 30 days, following the filing of responsive pleadings, the court shall submit the matter to non-binding mediation unless waived by mutual stipulation of both parties. The mediation process shall provide for the selection within 15 days by both parties of a disinterested third person as mediator, and shall be commenced within 30 days of the submittal and shall be concluded within 15 days from the commencement of the mediation unless a time requirement is extended upon a good cause showing to the court.

Judicial Arbitration If the matter remains in dispute, the case shall be submitted to judicial arbitration pursuant to Section 1141.10, et seq., of the Code of Civil Procedure, notwithstanding Code of Civil Procedure Section 1141.11. The civil discovery procedures of Code of Civil Procedure Section 2016, et seq., shall apply, consistent with the rules pertaining to judicial arbitration. In addition to the provisions of Code of Civil Procedure Section 1141.10, et seq., (a) arbitrators shall, upon stipulation of the parties, be experienced in construction law, and (b) any party appealing an arbitration award who does not obtain a more favorable judgment shall, in addition to payment of costs and fees, also pay the attorneys fees on appeal of the other party.

Interest on Award of Judgment In any suit filed pursuant to Paragraph (G)3.2, the Owner shall pay interest at the legal rate on any arbitration award or judgment, which interest shall begin to accrue on the date the suit is filed in a court of law.

- C. RESOLUTION OF CLAIMS OTHER THAN DEFINED CLAIMS The provisions of this Paragraph C shall apply to all claims that are not "Defined Claims," as such term is defined in Paragraph A (i.e., claims that are in excess of \$375,000.00).

Written Claim

If the Contractor is not satisfied with any action by the City Council to resolve the protest of any claim other than a Defined Claim, it shall file with the City Council, within fifteen (15) days after such determination, a written claim which shall comply with the requirements for a claim under Division 3.6 of Title 1 (commencing with Section 810) of the California Government Code. The City Council shall take action with respect to any such claim as provided in Division 3.6 of Title 1 of the Government Code. Denial of such claim by the City Council shall be a prerequisite to the institution of any legal proceeding challenging the action of the City Council. If the Contractor fails to file a claim within the time specified herein, it shall be deemed satisfied with the action of the City Council with respect to its protests, and such failure to file a claim shall be deemed to be a waiver of all claims and demands arising out of or relating to this Contract.

Limitation Period

Demand for Arbitration of any claim other than a Defined Claim shall be served upon the Owner within the time limits set forth in Division 3.6 of the California Government Code for commencement of legal proceedings against a local public agency.

Arbitration

Except as provided to the contrary herein, arbitration of any claim other than a Defined Claim may be initiated by the Contractor and shall be conducted in accordance with the provisions of California Code of Civil Procedure Sections 1280, et seq. The parties hereto agree that there shall be a single neutral Arbitrator who shall be selected in the following manner: (1) The Demand for Arbitration shall include a list of five names of persons acceptable to the Contractor to be appointed as Arbitrator. The Owner shall determine if any of the names submitted by Contractor are acceptable and, if so, such person will be designated as Arbitrator; (2) In the event that none of the names submitted by Contractor are acceptable to Owner or if for any reasons the Arbitrator selected in Step (1) is unable to serve, the Owner shall submit to Contractor a list of the five names of persons acceptable to Owner for appointment as Arbitrator to Contractor who shall in turn have 10 days in which to determine if one such person is acceptable; (3) If after Steps (1) and (2) the parties are unable to mutually agree upon a neutral Arbitrator, the matter of selection of an Arbitrator shall be submitted to the Los Angeles County Superior Court pursuant to Code of Civil Procedure Section 1281.6.

SECTION 3 – CONTROL OF THE WORK

Subsection 3-4 Authority of The Board and The Engineer

Add the following to the provisions of Subsection 3-4, "Authority of The Board and The Engineer":

The Engineer shall retain all written protests filed, and, upon completion of the work, shall submit all such protests to the City Council, together with a copy of the Engineer's prior written decisions for consideration by the City Council at the time of final acceptance of the work. The Contractor or its representative may appear and be heard by the City Council concerning any such protests. In connection with acceptance of the work and final payment under the Contract, the City Council shall make its determination with respect to each protest filed with the Engineer. The decision of the City Council shall be final.

Subsection 3-5 Inspection

Add the following to the provisions of Subsection 3-5, "Inspection":

Inspection work requested by the contractor outside of the prescribed working hours shall be paid by the contractor at the City's overtime rate.

Subsection 3-7 Contract Documents

Add the following to the provisions of Subsection 3-7, "Contract Documents":

All authorized alterations affecting the requirements and information given on the approved plans shall be in writing. No changes shall be made of any plan or drawing after the same has been approved by the Engineer, except by written direction of the Engineer. Should it appear that the work to be done, or any matter relative thereto is not sufficiently detailed or explained in these Specifications, Special Provisions, Technical Provisions, or Plans, the contractor shall apply to the Engineer for such further explanations as may be necessary and shall conform to such explanation or interpretation as part of the original specifications. In the event of doubt or questions relative to the true meaning of the specifications, reference shall be made to the City Council, whose decision thereon shall be final.

Record Drawings:

All corrections on record drawings shall be done in red ink. Record drawings shall be a control set of the construction plans kept on the site for daily recording of "as built" conditions. Show dimensioned location of all buried facilities, such as drains, sumps, pipe, valves, electrical conduit, and irrigation wire.

Dimensions must be taken from above ground permanent, architectural objects, not plants or irrigation heads. All dimensions, notes, etc., shall be legible.

Record drawing shall be reviewed prior to all progress payment requests and submitted prior to final inspection.

Subsection 3-10 Surveying

Add the following:

The Contractor shall preserve all benchmarks, monuments, survey marks, centerline ties and stakes and, in case of their impending removal or destruction by his/her operations he/she shall be responsible for notifying the City Engineer **prior** to their removal. Failure to provide such notification will result in the Contractor being liable for all costs associated with their replacement.

Permanent Survey Markers

The Contractor shall retain a Licensed Land Surveyor or a Registered Civil Engineer authorized to practice land surveying within the State to Reset Survey Monuments. The Contractor is responsible for the filing and recording of the Survey Monuments.

Survey Service

The Contractor shall retain a Licensed Land Surveyor or a Registered Civil Engineer authorized to practice land surveying within the State to provide construction staking. The Contractor is responsible for the accuracy of surveying adequate for construction.

Measurement and Payment. The following section is hereby added:

Full compensation for Construction Survey, including furnishing all labor, materials, tools, equipment, surveyor, supervision, and incidentals for doing all the work involved shall be considered as included in the other items of work.

Payment for monumentation restoration shall be paid at the contract unit price bid per intersection, including furnishing all labor, materials, tools, equipment, surveyor supervision, filing and recordation and other incidental for doing all the work involved and no separate payment shall be made thereof.

Subsection 3-12 Work Site Maintenance

Add the following to the provisions of Subsection 3-12, "Work Site Maintenance":

All excess dirt and construction debris shall be hauled away from job site each day.

Subsection 3-12.4 Storage of Equipment and Materials

Add the following to the provisions of Subsection 3-12.4, "Storage of Equipment and Materials":

Overnight stockpiling of construction debris or excavated materials is not allowed. Contractor must obtain written approval from the Engineer prior to storage of construction materials and equipment on the street where improvements are planned. Adequate flashing barricades shall be provided.

Subsection 3-13 Completion, Acceptance, and Warranty

Add the following to the provisions of Subsection 3-13, "Completion, Acceptance, and Warranty":

Final inspection and recommendation of completion by the Engineer does not constitute acceptance of the project. The contractor remains responsible for the project until acceptance of the work by the City Council.

SECTION 4 - CONTROL OF MATERIALS

Subsection 4-3 Inspection

Add the following to the provisions of Subsection 4-3, "Inspection":

At the option of the Engineer, the source of supply of each of the materials shall be approved by the

Engineer before delivery is started and before such material is used in the work. Representative preliminary samples of the character and quality prescribed shall be submitted by the contractor or producer of material to be used in the work, for testing or examination as desired by the Engineer. All tests of industry materials furnished by the contractor shall be made in accordance with commonly recognized industry standards or special methods and tests as prescribed in these specifications.

The Contractor shall furnish such samples of materials as are requested by the Engineer, without charge. No material shall be used until it has been approved by the Engineer. Samples will be secured and tested whenever necessary to determine the quality of material.

SECTION 5 – LEGAL RELATIONS AND RESPONSIBILITIES

Subsection 5-3 Labor

Add the following to the provisions of Subsection 5-3, "Labor":

Attention is directed to the provisions in Sections 1777.5 (Chapter 1411, Statutes of 1968) and 1777.6 of the Labor Code concerning the employment of apprentices by the contractor or any subcontractor under him.

Section 1777.5, as amended, requires the contractor or subcontractor employing tradesmen in any apprenticeable occupation to apply to the joint apprenticeship committee nearest the site of the public works project and which administers the apprenticeship program in that trade for a certificate of approval. The certificate will also fix the ratio of apprentices to journeymen that will be used in the performance of the contract. The ratio of apprentices to journeymen in such cases shall not be less than one to five except:

1. When unemployment in the area of coverage by the joint apprenticeship committee has exceeded an average of 15 percent in the 90 days prior to the request for certificate, or
2. When the number of apprentices in training in the area exceeds a ratio of one to five, or
3. When the trade can show that it is replacing at least 1/30 of its membership through apprenticeship training on an annual basis statewide or locally, or
4. When the contractor provides evidence that he employs registered apprentices on all of his contracts on an annual average of not less than one apprentice to eight journeymen.

The contractor is required to make contributions to funds established for the administration of apprenticeship programs if he employs registered apprentices or journeymen in any apprenticeable trade on such contracts and if other contractors on the public works site are making such contributions.

The contractor and any subcontractor under him shall apply with the requirements of Sections 1777.5 and 1777.6 in the employment of apprentices.

Information relative to apprenticeship standards, wage schedules, and other requirements may be

obtained from the Director of Industrial Relations, ex officio the Administrator of Apprenticeship, San Francisco, California, or from the Division of Apprenticeship Standards and its branch offices.

Subsection 5-3.4 Hours of Labor

Add the following to the provisions of Subsection 5-3.4, "Hours of Labor":

Eight hours constitutes a legal days' work. The contractor shall forfeit, as a penalty to the City of San Fernando, \$50.00 for each workman employed in the execution of the contract by the contractor is required or permitted to work more than eight hours in any one calendar day and 40 hours in any one calendar week in violation of the provisions of the Labor Code, and in particular, Sections 1810 to 1815, thereof, inclusive, except that work performed by employees of contractors in excess of eight hours per day, and 40 hours during any one week, shall be permitted upon compensation for all hours worked in excess of eight hours per day at not less than one-and-one-half times the basic rate of pay as provided in said Section 1815.

The contractor shall comply with Labor Code Section 1775 in accordance with said Section 1775, the contractor shall forfeit as a penalty to the City of San Fernando, \$50.00 for each calendar day or portion thereof, for each workman paid less than the stipulated prevailing rates for such work or craft in which such workman is employed for any work under the contract by him or by any subcontractor under him in violation of the provisions of the Labor Code and in particular, Labor Code Sections 1770 to 1780, inclusive. In addition to said penalty and pursuant to said Section 1775, the difference between such stipulated prevailing wage rates and the amount paid to each workman for each calendar day or portion thereof for which each workman was paid less than the stipulated prevailing wage rate shall be paid to each workman by the contractor.

In accordance with the provisions of Section 1770 to 1777 inclusive, of the Labor Code of the State of California, the City Council of San Fernando has adopted the general prevailing rates of per diem wages applicable to the work to be done as have been determined by the Director of the Department of Industrial Relations for the State of California.

Subsection 5-4 Insurance

Add the following to the provisions of Subsection 5-4, "Insurance":

The public liability insurance shall include protection from claims caused by automobiles, trucks, or other vehicles of the contractor or any subcontractor while in use both within and outside the contract premises. The property damage insurance shall cover damage or destruction of any and all property other than that which is owned, leased, or in the care, custody or control of the Contractor or any subcontractor, with the liability limit applying to any one (1) accident, disaster or claim. All coverage provided by Contractor shall be considered primary and shall be completely exhausted before City coverage, if any and to be considered secondary, is exercised.

By appropriate endorsement, such policies of insurance required shall name the City of San Fernando as additionally insured with the Contractor with respect to the construction project described in these specifications and shall provide that such insurance coverage shall not be canceled or reduced without thirty (30) days prior written notice to the City of San Fernando. Said endorsement shall be a separate document. Certificates of the insurance carried evidencing such insurance coverage shall be delivered to the City of San Fernando concurrently with the execution of the contract by the Contractor.

Subsection 5-7 Safety

Add the following to the provisions of Subsection 5-7, "Safety":

In the event that the Contractor fails to adequately provide for the public safety during the course of construction under this contract, and the City is required to provide for said public safety, the Contractor shall pay the City the cost of each service call, which will include all direct labor and material costs including fringe benefits, overhead, and applicable rental rates for the various pieces of equipment. Any and all costs incurred by the City as a result of the failure of the Contractor to provide for the public safety will be deducted from the amount due to the Contractor for the work done under this contract.

SECTION 6 – PROSECUTION AND PROGRESS OF THE WORK

Subsection 6-1 Construction Schedule and Commencement of Work

Add the following to the provisions of Subsection 6-1, "Construction Schedule and Commencement of Work":

The Contractor shall begin work within three (3) days of the commencement date stated in the Notice to Proceed and shall diligently prosecute the same to completion before the time required to complete the work stated in the Contractor's Proposal expires.

Construction work is limited to normal working hours unless prior written approval is obtained from the Engineer. Normal working hours for construction are between 7 a.m. and 6 p.m. Night time work is an option for this project. Post parking restrictions at least 72 hours before work begins.

Contractor shall provide a schedule, which may include the staggering of the work in parking lots that have multiple ingress/egress locations in order to keep lots accessible.

Subsection 6-3 Time of Completion

Add the following to the provisions of Subsection 6-3, "Time of Completion":

Where a single shift is worked, eight (8) consecutive hours between 7 a.m. and 5 p.m. shall constitute a day's work at straight time for all workers. Forty (40) hours between Monday, 7 a.m., and Friday, 5 p.m. shall constitute a week's work at straight time. Holidays as herein referred to shall be deemed to be:

- | | |
|---------------------------|--------------------------|
| ▶ New Year's Day | ▶ Independence Day |
| ▶ Martin Luther King Day | ▶ Labor Day |
| ▶ President's Day | ▶ Veterans Day |
| ▶ Cesar Chavez's Birthday | ▶ Thanksgiving Day |
| ▶ Memorial Day | ▶ Day after Thanksgiving |
| ▶ Juneteenth | ▶ Christmas |

Subsection 6-4 Delays and Extensions of Time

Add the following to the provisions of Subsection 6-4, "Delays and Extensions of Time":

The Contractor shall not be assessed with liquidated damages nor the cost of engineering and

inspection during any delay in the completion of the work caused by Acts of God or of war, acts of the City, fire, floods, epidemics, quarantine restrictions, strikes, freight embargoes, and weather or delays of subcontractors due to such causes, provided that the Contractor shall within ten (10) days from the beginning of any such delay notify the Engineer in writing of the cause of delay, who shall ascertain the facts and the extent of the delay, and his findings of the facts thereon shall be final and conclusive.

Subsection 6-9 Liquidated Damages

Add the following to the provisions of Subsection 6-9, "Liquidated Damages":

It is agreed by the parties to the contract that liquidated damages for work under this contract is the sum of One Thousand Dollars (\$1,000.00) per day for each and every day's delay beyond the time prescribed to complete the work. Contractor agrees to pay such liquidated damages as herein provided, and in case the same are not paid, Contractor agrees that the City of San Fernando may deduct the amount thereof from any money due or that may become due the Contractor under the contract.

It is further agreed that in case the work called for under the contract is not finished and completed in all parts and requirements within the time specified, the City Council shall have the right to extend the time for completion or not, as may seem best to serve the interest of the City; and if it decides to extend the time limit for the completion of the contract, it shall further have the right to charge to the Contractor, his heirs, assigns or sureties; and to deduct from the final payment for the work, all or any part, as it may deem proper, of the actual cost of engineering, inspection, superintendence, and other overhead expenses which are directly chargeable to the contract, and which accrue during the period of such extension, except that the cost of final surveys and preparation of final estimates shall not be included in such charges.

SECTION 7 - MEASUREMENT AND PAYMENT

Subsection 7-3 Payment

Add the following to the provisions of Subsection 7-3, "Payment":

It is mutually agreed between the parties to the contract that no certificate given or payments made under the contract, except the final project acceptance, shall be conclusive evidence of the performance of the contract, either wholly or in part, against any claim of the party of the first part, and no payment shall be construed to be an acceptance of any defective work or improper materials.

The Contractor further agrees that the payment of the final amount due under the contract, and the adjustment and payment for any work done in accordance with any alterations of the same, shall release the City of San Fernando, City Council, and the Engineer from any and all claims of liability on account of work performed under the contract or any alteration thereof.

Subsection 7-3.2 Partial and Final Payment

Add the following to the provisions of Subsection 7-3.2, "Partial and Final Payment":

The City shall, once in each month, cause an estimate in writing to be made by the Engineer of the total amount of work done and the acceptable materials furnished and delivered by the Contractor on the ground and not used, at the time of such estimate; and the value thereof. The City of San

Fernando shall retain five percent (5%) of such estimated value of the work done and fifty percent (50%) of the value of the materials so estimated to have been furnished and delivered and unused as aforesaid as part security for the fulfillment of the contract by the Contractor, and shall monthly pay the Contractor, while carrying on the work, the balance not retained, as aforesaid, after deducting therefrom all previous payments and all sums to be kept or retained under the provisions of the contract. No such estimate or payment shall be required to be made, when, in the judgment of the Engineer, the work is not proceeding in accordance with the provisions of the contract, or when in his judgment, the total value of the work done since the last estimate amounts to less than Three Hundred Dollars (\$300.00).

The Contractor may be required to submit updated work schedules and current record drawings (as-built) with requests for progress payments.

Subsection 7-4.3 Markup

Add the following to the provisions of Subsection 7-4.3, "Markup":

Work by Contractor. The following percentages shall be added to the contractor's costs and shall constitute the markup for all supervision and management (direct or indirect); home office and field overhead and all profits, which shall be deemed to include all items of expense not specifically designated as materials or tool and equipment rental as in sections 7-4.2.2, "Materials", and 7-4.2.3, "Tool and Equipment Rental".

Labor	20%
Materials	15%
Equipment Rental	15%
Other Items and Expenditures	15%

To the sum of the costs and markups provided for in this subsection, a maximum of one percent (1%) shall be added as compensation for bonding upon proof of actual payment to the suret(ies).

Add the following to the provisions of Subsection 7-4.3.2, "Work by a Subcontractor":

When all or any part of the extra work is performed by a subcontractor, the markup established in subsection 7-4.3 shall be applied to the subcontractor's actual cost of such work, to which a markup of 10 percent on the first \$2,000 of the subcontracted portion of the extra work and a markup of 5 percent on work in excess of \$2,000 of the subcontracted portion of the extra work may be added by the contractor.

SECTION 8 - FACILITIES FOR AGENCY PERSONNEL

No field offices for AGENCY personnel shall be required; however, the AGENCY's personnel shall have the right to enter upon the project at all times and shall be admitted to the offices of the Contractor if so provided by the Contractor for his own personnel.

SECTION 400 PROTECTION AND RESTORATION OF EXISTING IMPROVEMENTS

Add the following to the provisions of subsection 400-1, "General"

Existing improvements damaged or removed without written authorization shall be replaced by the contractor at no cost to the City. The contractor shall leave the work area in the same or better condition as compared to before beginning contract work.

SECTION 402 - UTILITIES

Subsection 402-1 Location

Add the following to the provisions of Subsection 402-1, "Location":

Utilities for the purpose of these Special Provisions shall be considered as including but not limited to; pipelines; conduits; transmission lines; appurtenance of both public utilities and private industries, business, or individual; storm drains; sanitary sewers; and street lighting conduits.

The City has endeavored to locate and indicate on the drawings all underground utilities, facilities, and obstructions within the limit of the work under this contract or so nearly adjacent thereto as to interfere with the execution of the work. However, the accuracy and completeness of the utilities location indicated on the plans is not guaranteed. Sewer service lines, gas service connections, and street lights and traffic signal conduits may not be shown on the plans.

The contractor is responsible to determine the exact location of utilities and its service connections during construction. The contractor shall notify the City of the exact location of any utility or service connection which is not shown or incorrectly shown on the plans.

The contractor shall be expected to maintain liaison with the affected utility company representatives, and shall notify them prior to beginning of the job and each time the particular utility is or could possibly be affected at least 24 hours in advance:

1.	Frontier Communications	800-483-1000
2.	Southern California Edison Company	800-611-1911
3.	Southern California Gas Company	800-427-2200
4.	San Fernando Water Department	818-898-1293
5.	L.A. City Municipal Services	800-342-5397
6.	L.A. Metropolitan Water Dist.	626-844-5610
7.	Spectrum Cable	818-700-6500
8.	Plains All America Pipeline	800-708-5071

SECTION 601 TEMPORARY TRAFFIC CONTROL FOR CONSTRUCTION AND MAINTENANCE WORK ZONES

Add the following to the provisions of Section 601, "Temporary Traffic Control for Construction and Maintenance Work Zones":

In the event that any street must be closed, request must be received by the Engineer for approval and the following parties shall be notified at least 48 hours in advance.

a.	Public Works Department	818-898-1293
----	-------------------------	--------------

- | | | |
|----|-------------------|--------------|
| b. | Police Department | 818-898-1267 |
| c. | Fire Department | 818-989-8561 |
| d. | Mauran Ambulance | 818-365-3182 |

The Contractor may choose to comply with the requirements of W.A.T.C.H. (Work Area Traffic Control Handbook) in providing devices and signage for pedestrian and vehicular traffic. The Contractor shall provide flagmen as necessary.

Overnight parking of construction equipment in the project site shall comply with the City parking restriction/regulations. Contractor shall provide adequate flashing barricades.

SPECIAL PROVISIONS

PART 1

SEAL COATS & CRACK TREATMENT

PART 1 – GENERAL

1.01 SUMMARY OF WORK

- A. Crack Treatments ("Crack Sealing") shall conform to Section 37-6 of the Caltrans Standard Specifications (Standard Specifications) and these Special Provisions.
- B. The scope of work shall include and not be limited to:
 - 1. Crack treatment shall occur to cracks occurring within the project limits, full length and width as deemed necessary for crack treatment.
 - 2. Cracks 1/2" wide and wider shall be filled before surface treatment is applied. Cracks shall be routed to a depth and width of 1/2" prior to sealing.
 - 3. Crack sealing shall be performed after any required pavement repairs or grinding operations and prior to placing flexible pavement coatings, pavement reinforcing fabric, or overlays.
- C. Fog Seal shall conform to Section 37-4 of the Standard Specifications and these Special Provisions.
- D. The scope or work shall include, but not be limited to:
 - 1. Surface preparation of the area to be receive the conventional fog seal.
 - 2. Crack treatment prior to conventional fog seal application.
 - 3. Inspection of area to be treated prior to application of conventional fog seal and reworking any areas noted to be deficient by Engineer.
 - 4. Application of conventional fog seal including inspection and repairs of any deficient areas

1.02 SUBMITTALS

- A. Submittals for Crack Treatments shall conform to Section 37-6.01 of the Standard Specifications and submittals for Fog Seal shall conform to Section 37-4.01 of the Standard Specifications and these Special Provisions.
- B. Submit Safety Data Sheets (SDS), certificates of compliance, and test results as required in the Standard Specifications, for the review and approval of the Engineer.
- C. Prior to disposal of excess material submit requests in writing for approval of the Engineer.
- D. Sand gradation test results, for the crack treatment material, under California Test 202.

1.03 CONSTRUCTION

- A. Construction for Crack Treatment shall comply with the provisions set forth in Section 37-6.03 "Construction", and construction for Fog Seal shall comply with the provisions set forth in Section 37-4.02C "Construction" of the Standard Specifications and these special provisions.
- B. Construction notices shall receive the approval and authorization of the Engineer before the Contractor sends the notice to property owners and these notices shall contain the following:

1. Describe the work to be performed.
2. Detail streets and limits of activities.
3. Indicate dates and work hours.

1.04 QUALITY ASSURANCE AND QUALITY CONTROL

- A. Comply with Section 37-1.01D(1) "General" and Section 37-6.01D "Quality Assurance" for Crack Treatment and with Section 37-4.02A(4) including its subparts of the Standard Specifications and these Special Provisions.
- B. The County reserves the right to sample components at the mixing site for testing and acceptance.

1.05 AMBIENT CONDITIONS.

- A. The Conventional Fog Seal shall not be placed when rain is likely prior to curing of the product or when freezing conditions are expected within 24 hours of application. Both ambient temperature and roadway surface temperature shall be minimum 50° F (10° C) and rising before beginning application.

PART 2 – PRODUCTS

2.01 MATERIALS

- A. Comply with Section 37-6.02B "Crack Treatment Material" of the Standard Specifications and these Special Provisions.
- B. Crack treatment materials shall Maxwell Gap Filler for sealing cracks larger than 1/2" and CRAFCO Crack Sealer for sealing cracks smaller than 1/2" or approved alternate material.
- C. The asphalt emulsion shall be designated CQS-1H and meet the specification as listed in AASHTO M 208. The asphalt emulsion shall contain asphalt and water and shall be diluted 1:1 with water at the point of manufacture. The asphalt emulsion shall be tested prior to dilution to ensure compliance with applicable specifications. Asphalt emulsion delivered to the project shall be accompanied by a laboratory certification of analysis and any other certifications as deemed necessary or advisable. Aggregate is used only as a blotting agent in areas of excess emulsion application. The aggregate shall be any suitable manufactured or natural sand with top-sized material of less than 0.25 inch (0.635 cm).

PART 3 – EXECUTION

3.01 SEQUENCE OF WORK

- A. Prior to beginning work, the Contractor shall stake the limits of work for the review and approval of the Engineer. Adjust limits of work as instructed by the Engineer to meet the design intent.
- B. The edge lines of the limits of the resurfacing application on both sides of the street shall be maintained in a neat uniform line.
- C. Contractor shall furnish and maintain in good working condition all tools and equipment necessary to do the work with personnel efficiently and skillfully.
- D. Sweeping shall be done before the end of the day to remove any excess material or debris from the roadway. Sweeping shall be performed at driveways, gutters, sidewalks, and other locations with public access in the project limits, at the end of each day during resurfacing activities.

3.02 SURFACE PREPARATION

- A. Immediately prior to performing crack sealing, cracks shall be cleaned by the use of high pressure compressed air, such that all vegetation, dirt, and other objectionable materials are removed. The compressed air shall be filtered of moisture and oils. Under damp conditions, a hot compressed air lance shall be utilized to dry the cracks as well.
 - 1. Route large cracks (0.25 inch and larger). The width of the routing should be 0.25 inch (5 mm) wider than the crack width. The depth shall be equal to the width of routing, plus 0.25 inch (5 mm) or deeper if debris is still observed.
 - 2. Wider and deeper cracks may be partially filled with coarse sand or other granular materials, a backing rod (to reduce the volume of asphalt emulsion), or other fill material needed to restore the asphalt surface.
 - 3. Sealant material shall be applied at the temperature and rate recommended by the manufacturer.
 - 4. Sealant shall be applied to a slightly overfilled condition, then struck off with a guideshoe, plate, or squeegee to produce a band of material two (2) inches to four (4) inches in width, centered over the crack. Strike-off height shall be less than 1/8-inch above the pavement surface, to alleviate the potential bump in the overlay from crack sealant.
 - 5. Extensively cracked pavement areas (alligator cracking) shall not be crack sealed unless specifically directed by the Engineer. Where the Engineer determines excessive coating or thickness of pavement crack sealant by the Contractor, the Contractor shall perform the necessary pavement base repairs to correct the problem prior to placement of any flexible pavement coating, pavement reinforcing fabric, or overlay.
- B. Contractor shall remove any and all vegetation within the road resurfacing limits by an acceptable and approved means (i.e. manual and/or mechanical) ensuring that dirt and debris are removed from cracks and voids.
- C. Contractor shall be responsible for performing supplemental cleaning, hand sweeping, and brooming, as necessary, until the roadway is free of hazards and obstructions. Contractor shall be liable for claims or damages related to roadway debris. Roadway shall be clear and safe for traffic at all times.
- D. Contractor shall set references to and record locations of each utility to be recovered and raised after paving operations.
- E. Before applying the crack sealant, cover manholes, valves, monument covers, grates, and other exposed facilities located within the area of application, using plastic or oil resistant construction paper secured by tape or adhesive to the facility being covered. All traces of plastic and residual shall be removed from all manhole covers, drain inlet covers, and all other utility covers as quickly as possible, after the application of the crack sealant and prior to overlaying with Hot Mix Asphalt in accordance with Section 39 of these Special Provisions.

3.03 PAVEMENT STRIPING AND MARKINGS

- A. Contractor shall prepare the road surface before any seal coat related activities take place, by removing all existing paint striping (if any) as well as sweeping or brooming the surfaces with a power broom.
 - 1. Should the asphalt surface be damaged during removal, the Engineer may request a leveling course of HMA to be placed prior to application of the surface treatment at no additional cost to the contract.

- B. Lane lines and pavement markings, with the exception of crosswalks and stop bars, may be removed up to 72 hours in advance of the surface treatment. Crosswalks and stop bars may be removed 24 hours in advance of the surface treatment.
- C. All lane lines and pavement markings shall be referenced with temporary lane markers (tabs) according to the manufacturer's recommendations. Maintain the markers by replacing lost or damaged markers daily.
- D. Temporary lane line markers used for centerlines shall have yellow bodies and yellow reflective sheeting on both sides.
- E. Temporary lane markers used for lane lines or edge lines shall have the same body and reflector color as required for the permanent striping and the reflective sheeting shall only be required on the side that faces oncoming traffic.
- F. The patterns and spacing for the temporary pavement markers shall be as follows:
 - 1. Long Lines: Place one (1) marker at 50-foot intervals.
 - 2. Broken Lines: Place one (1) marker at the beginning of each broken line.
 - 3. Double Yellow Lines: Place two (2) markers side by side with a four (4) inch separation between markers at 50-foot intervals.
 - 4. Stop Bar: Place one (1) marker, on either side of the stop bar, across the travel lanes.
- G. The Engineer shall approve the surface preparation prior to sealing activities.

3.04 APPLICATION RATES

- A. The asphalt emulsion shall be applied by means of a pressure distributor. Application shall be a uniform, continuous, full coverage spread and under such pressure as to thoroughly coat the surface at the specified rate. The temperature of the asphalt emulsion during application shall be maintained between 100 - 160° F (37.8 - 71.1° C).
- B. Application rate shall be within the range of 0.08-0.10 gal/sq yd at 50/50 dilution. If fog seal becomes tacky sprinkle with water as required.

3.05 EQUIPMENT

- A. Contractor's sealing equipment shall adhere to the requirements of Section 37-1.03B "Equipment" of the Standard Specifications and these Special Provisions.
- B. The distributor shall be self-powered and capable of providing a uniform application rate of asphalt binder varying from .05-1.00 gal/yd² over a variable width up to 16 feet in a single pass. Nozzles on the distributor bar shall be fully operational and of the size suggested by the manufacturer to apply the intended application rate. Coverage shall be full with no overlapping areas or bare spots. The distributor shall be self-powered and include computerized application controls and be capable of heating material to 160° F (71° C).

3.06 FINISHING

- A. Crack seal areas shall be protected from traffic until the material has sufficiently cured and does not track. Any damage or loss of material from freshly placed crack seal material shall be replaced by the Contractor.

3.07 LIMITATIONS – NOT USED

PART 4- MEASUREMENT AND PAYMENT

- A. The contract lump sum price paid for "Crack Sealing" shall include full compensation for

furnishing all labor, materials, tools, equipment and incidentals, and for doing all the work, as shown on the Plans, as specified in the Standard Specifications, these Special Provisions, and as directed by the Engineer and no additional compensation will be allowed.

- B. The payment at the Contract unit price per square yard (SY) for "Fog Seal", shall include full compensation for furnishing all labor, materials, tools, equipment, and incidentals, and for doing all the work involved, as shown on the plans, as specified in the Standard Specifications and these Special Provisions, and as directed by the Engineer and no additional compensation will be allowed, therefore

SPECIAL PROVISIONS

PART 2

SIGNING, STRIPING, AND PAVEMENT MARKERS

All equipment, materials, and components for signing and striping, and the installation thereof, shall conform to the 2010 Caltrans Standard Plans, and Standard Specifications, Section 56, "Signs," Section 84, "Traffic Stripes and Pavement Markings," and Section 85, "Pavement Markers," unless otherwise noted in these Special Provisions and on the Plans. These Plans and Specifications are hereinafter referred to as State Standard Plans and State Standard Specifications. Copies of these documents are available from Caltrans, District 7 office at 100 South Main Street, Los Angeles, California 90012 or from Caltrans, 6002 Folsom Boulevard, Sacramento, California 95819, (916) 445-3520.

The plans provided may not reflect existing conditions. Contractor may use other means of resources such as Google Maps to identify existing striping and pavement markings.

All materials required for the completion of work as shown on the Plans shall be provided by the Contractor.

SECTION 56 - SIGNS

56-4 ROADSIDE SIGNS

56-4.03 Construction. Relocated signs shall be installed using existing posts at new locations and shall be set at a minimum 30-inch depth and at a minimum 12-inch square portland cement concrete (PCC). The post depth of the concrete footing shall be sufficient to extend at least 6-inches below the bottom of the posts. ¼-inch expansion paper shall be placed between the sign foundation and sidewalk.

New signs shall be installed using metal posts set at a minimum of 30-inch depth in a minimum 12-inch square PCC, except as specified otherwise, the metal post shall be a 2-inch square, galvanized steel "Quick Punch" post. The length of the metal post shall be sufficient to extend from the top of the sign to 30-inches below the top of the concrete footing and provide a 7-foot clearance between the finished grade and the bottom of the sign. The depth of the concrete footings shall be sufficient to extend at least 6-inches below the bottom of the posts. ¼-inch expansion paper shall be placed between the sign foundation and sidewalk.

Marker and delineators shall conform to the provision in Section 82, "Markers and Delineators."

56-4.04 Payment. Payment for signing shall be included in the bid price for signing and striping, and no additional compensation will be allowed therefor.

SECTION 84 - TRAFFIC STRIPES AND PAVEMENT MARKINGS

84-1 GENERAL

84-1.02 Materials. Traffic stripes, pavement markings, crosswalks, and arrows shall be thermoplastic unless otherwise shown on the Plans. Curb markings shall be paint, 2 coats. Contractor shall repaint all curb markings within the project limits.

84-1.03A Tolerances and Appearance. The Contractor shall furnish the necessary control points for all striping and markings, and shall be responsible for the completeness and accuracy thereof to the satisfaction of the Engineer.

The Contractor shall establish all traffic striping between these points by stringline or other method to provide striping that will vary less than ½-inch in 50-feet from the specified alignment.

When no previously applied figures, markings, or traffic striping are available to serve as a guide, suitable layouts shall be spotted in advance of the permanent paint application. Traffic lines may be spotted by using a rope as a guide for marking spots every 5-feet, by using a marking wheel mounted on a vehicle, or by any other means satisfactory to the Engineer.

The Contractor shall mark or otherwise delineate the traffic lanes in the new roadway or portion of roadway, or detour before opening it to traffic.

The Contractor shall provide an experienced technician to supervise the location, alignment, layout, dimensions, and application of the paint.

Spotting shall be completed prior to the removal of any existing stripes. Existing stripes and markings shall be removed prior to painting new stripes and markings, but in no case shall any section of street be left without the proper striping for more than 24 hours, or over weekends or holidays.

Existing traffic stripes (including raised pavement markers), pavement legends, and markings that do not conform to the plans shall be removed by wet sandblasting per Section 15-2.02C, "Remove Traffic Stripes and Pavement Markings," and Section 15-2.02D, "Remove Pavement Markers," of the State Standard Specifications.

84-2 THERMOPLASTIC TRAFFIC STRIPES AND PAVEMENT MARKINGS

84-2.02 Materials. Traffic striping shall be thermoplastic including crosswalks, arrows and other pavement legends.

The installation of traffic stripes includes placement of raised pavement markers when called for on the plans.

Adhesive for raised pavement markers shall be per Section 85, "Pavement Markers." Epoxy shall be the Rapid Set type.

84-2.04 Payment. Payment for striping details, pavement markings, and curb marking shall be included in the price bid for signing and striping, and no additional compensation will be allowed.

84-3 PAINTED TRAFFIC STRIPES AND PAVEMENT MARKINGS

84-3.02 Materials. Paint for curb markings shall be ready-mixed rapid dry type.

84-3.03 Construction. Paint shall be applied in two coats.

The second coat of paint shall be applied no less than 24 hours from application of the first coat.

84-3.07 Payment. Payment for striping details, pavement markings, and curb marking and repainting existing painted curb shall be included in the price bid for signing and striping, and no additional compensation will be allowed.

SECTION 85 – PAVEMENT MARKERS

85-1.03C Epoxy Adhesive. Adhesive for raised pavement markers shall be rapid set type epoxy.

Removal of pavement markers shall be per Section 15-2.02D, "Remove Pavement Markers."

85-1.04 Payment. Payment for pavement markers shall be included in the lump-sum price bid for signing and striping, and no additional compensation will be allowed therefor.

SPECIAL PROVISIONS

PART 3

ASPHALT WORK

Excavation:

1. Remove existing damaged HMA.
2. Remove existing aggregate base material necessary to provide for a sub-grade with a minimum of 95% compaction.
3. Any substandard soils that do not meet minimum compaction will be excavated and replaced until the sub-grade meets a minimum of 90% compaction.
4. All edges of excavation areas will be saw cut.

Aggregate Base Placement:

1. AB will be compacted to a minimum of 95% compaction.

HMA Placement:

1. Contractor will install a minimum of 3 inches in depth of HMA.
2. Unless otherwise approved by the Project Manager each course of pavement shall not exceed 2 inches compacted thickness. Where compacted thickness of any pavement course is more than 2 inches, the paving material shall be compacted in two or more layers each of not less than 1-inch compacted thickness.

Spread and compact minor HMA by methods that produce an HMA surfacing:

1. Textured uniformly
2. Compacted firmly
3. Free of depressions, humps, and irregularities

Compact minor HMA with a vibratory roller providing a minimum of 7,000 pounds centrifugal force. With the vibrator on, compact at least 3 complete coverages over each layer, overlapping to prevent displacement. The speed of the vibratory roller in miles per hour must not exceed the vibrations per minute divided by 1,000. If the HMA layer thickness is less than 0.08 foot, turn the vibrator off. Complete the first coverage before the mixture's temperature drops below 250 °F.

The owner or his designated representative will inspect all excavations, soil compaction and sub base before HMA placement.

SPECIAL PROVISIONS

PART 4

MOBILIZATION

PART I – GENERAL

1.01 DESCRIPTION

- A. Mobilization shall consist of the following work:
 - 1. Bonds and Insurance.
 - 2. Schedule of values.
 - 3. Mobilization of materials and equipment to the site.
 - 4. Providing construction fencing, office trailers, temporary sheds, temporary utilities, temporary facilities, and all preparatory work prior to the commencement of productive work at the site required under this Contract.
 - 5. Provide construction utilities. The Contractor shall locate utility connection points and make necessary arrangements with utility agencies for construction, water, power, and communication, etc. In the event that such utilities are not easily available, then the Contractor shall provide such utilities at no additional cost to the City.
 - 6. Preparation of all necessary permits, submittals, notifications, record drawings, and other documentation.
 - 7. Coordination and any other items required to complete the construction not otherwise measured and paid for.
 - 8. Demobilization of all of materials and equipment from the site.
 - 9. On-going and final site clean-up.
- B. Ground-disturbing activities may only occur between April 1st to October 15th, unless otherwise approved by the Engineer
- C. Paving work is expected to occur during favorable weather conditions.

PART 2 – PRODUCTS – NOT USED

PART 3 – EXECUTION

3.01 MOBILIZATION AND DEMOBILIZATION

- A. The Contractor shall inspect the site to observe actual field conditions prior to bidding the project.
- B. Mobilization shall also include finish work and operations, (demobilization) including, but not limited to, removal of personnel, equipment, supplies, and incidentals from the project site and clean-up of the project site. The Contractor shall not demobilize equipment from the site until the project is accepted as complete, unless directed otherwise in writing by the Engineer.
- C. Mobilization shall also include preparation of all necessary permits, submittals, notifications, and other documentation necessary for the performance of the work.
- D. Contractor shall clean all equipment of dirt, mud, and plant material, prior to entering the work areas, to prevent the introduction of invasive plants.

3.02 PERMITS AND REGULATIONS

- A. The Contractor shall obtain all other permits required for the performance of the work.
- B. The Contractor shall comply with the SWRCB requirements.
- C. The Contractor shall comply with County's and the Regional Water Quality Control Boards Erosion and Sediment Control Best Management Practices (BMP).

3.03 PROTECTION OF EXISTING PROPERTY AND CONDITIONS

- A. Protection of Work and Property:
 - 1. Confine the storage of materials and workmen's operations to the limits established on the Contract Documents and by law, permits, and/or directions of the Engineer. Do not unreasonably encumber the premises with materials.
 - 2. Contractor is responsible for the protection and preservation of all materials and equipment located on the construction site.
 - 3. Provide watchman services as may be deemed necessary to safeguard properly all materials, tools, appliances, and work. The City will not assume any responsibility for the loss of or damage to materials, tools, appliances, or work arising from acts of theft, vandalism, malicious mischief, or other causes which may occur during or after working hours.
 - 4. Contractor shall promptly comply with all reasonable requests of the Engineer to protect the site.
 - 5. Contractor shall repair or replace all work performed or materials, supplies, or equipment furnished which may be damaged or lost by any cause, during the construction of the project, other than acts of God, to the satisfaction of the Engineer. Costs for such repairs or replacement shall be considered as part of the unit cost for all working being performed and is not eligible for additional reimbursement.
- B. Contractor shall be responsible for any damage to all roads, existing vegetation, existing buildings, utilities, and other property and improvements resulting from the Contractor's use and shall repair all damage resulting from such use to the satisfaction of the Engineer and at no cost to City.
- C. Contractor's Staging Area: Store construction materials and equipment within boundaries of designated staging and storage areas approved by the Engineer.
- D. Tree and Plant Protection:
 - 1. Do not store materials or equipment or operate or park equipment under the branches of any existing plant, to remain, except as actually required for construction in those areas.
 - 2. Provide barricades, fences, or other barriers as necessary at the drip line to protect existing plants and trees from damage during construction.
 - 3. Notify Engineer where Contractor presumes grading or other construction called for by Contract Documents may damage existing plants/trees to remain.
 - 4. If existing plants to remain are damaged during construction, Contractor shall replace such plants with others of the same species and size as those damaged or as directed by Engineer, at no cost to the County.

3.04 EXISTING UTILITIES

- A. The Contractor shall identify, locate, and protect all existing utilities within the limits of work, including onsite and offsite access routes.
- B. The location of existing utilities and underground facilities known to the City are shown in their approximate location based on information available at the time of

preparing the Contract Documents. The actual location, size, type, and number of utilities and underground facilities may differ from that shown, and utilities or underground facilities may be present that are not shown.

- C. Obtain from the respective agencies the best available current information on location, identification, and marking of existing utilities, piping, conduits, and other underground facilities before beginning any excavation. Call Underground Service Alert at 811 for information at least 48 hours in advance of beginning work.
- D. The Contractor will have to coordinate location, connection points for construction power, water, communication etc., with respective utility.



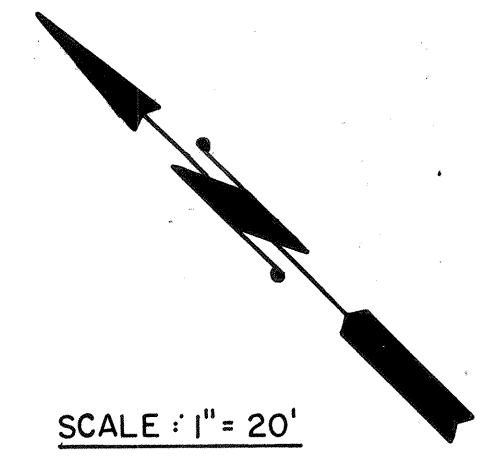
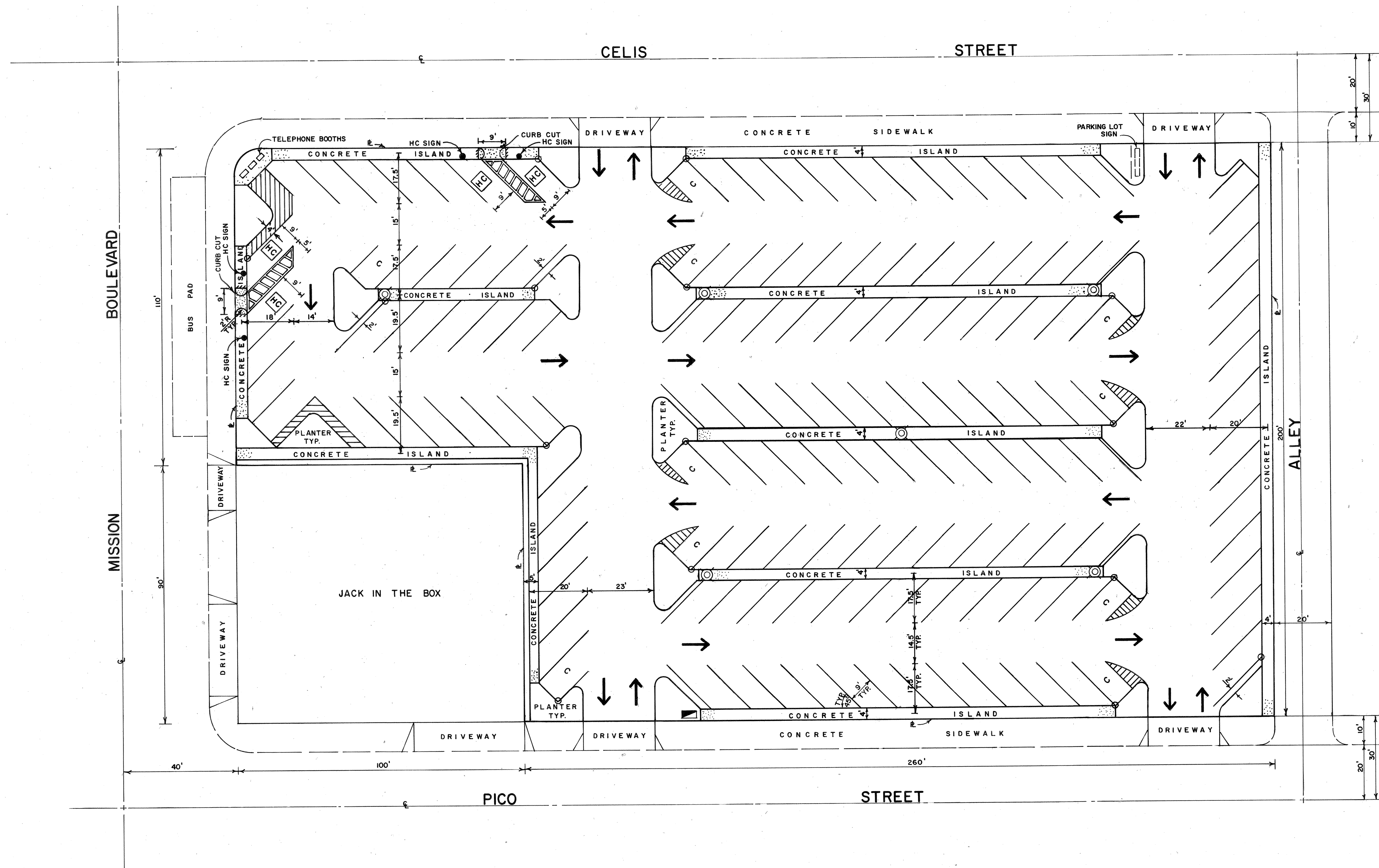

3.06 ACCESS TO THE PROJECT SITE

- A. Access to the site is over public roads. Exercise care in the use of such roads and repair any damage to the satisfaction of the City or agency having jurisdiction over the road.
- B. Under no circumstances shall the Contractor use any other private roads that are not designated for access.
- C. Do not track mud onto private or public roads. The Contractor shall employ a street sweeper as needed to keep all paved surfaces free of tracked mud or dirt.

PARKING LOT MAPS





LEGEND

-  ELECTRICAL CONTROLLER
-  PARKING LOT LIGHT
-  PARKING STALL FOR COMPACT CAR
-  CONTROLLING POINT FOR STRIPING.

NOTE

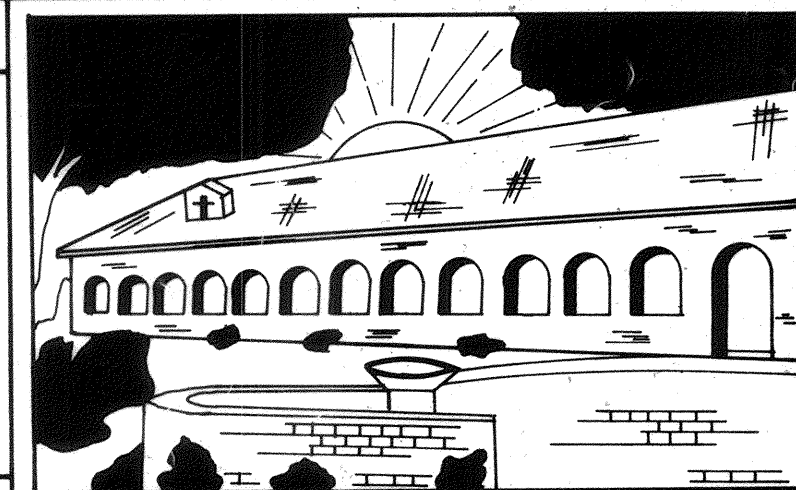
CUT IN CONCRETE SIDEWALK FOR HANDICAP SIGNS SHALL BE AT THE SCORE LINES. CUT IN CONCRETE ISLAND SHALL BE SQUARE (WIDTH OF ISLAND PAVEMENT).

JOB NO. 7332		
SAN FERNANDO, CALIFORNIA		
SLURRY SEAL, COATING, STRIPING AND MARKING OF PARKING LOT NO. 3		
 CITY ENGINEER	22122 R.C.E. NO.	4-13-90 DATE
R. A. NAVARRO - ASST. CITY ENGINEER		SHEET 2 OF 8
DESIGN R. A. NAVARRO	DRN. SAM IBRAHIM	DATE FEBRUARY, 1990
		PLAN MS-532

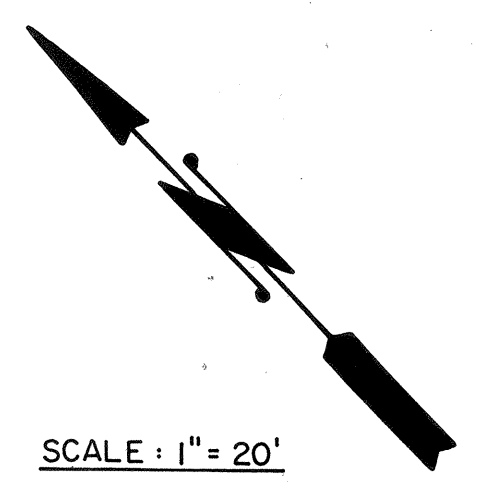
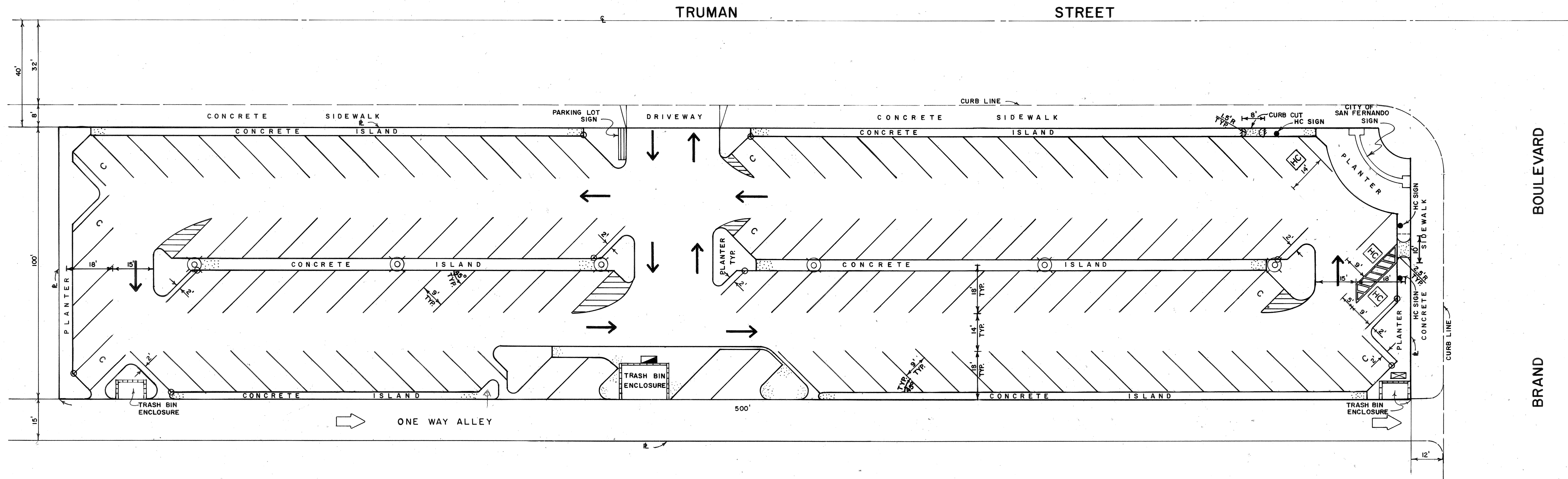

SCALE: 1" = 20'

LEGEND

- ELECTRICAL CONTROLLER
- PARKING LOT LIGHT
- IRRIGATION CONTROLLER
- PARKING STALL FOR COMPACT CAR
- CONTROLLING POINT FOR STRIPING

NOTE

CUT IN CONCRETE SIDEWALK FOR HANDICAP SIGNS SHALL BE AT THE SCORE LINES. CUT IN CONCRETE ISLAND SHALL BE SQUARE (WIDTH OF ISLAND PAVEMENT).

JOB NO. 7332

SAN FERNANDO, CALIFORNIA

**SLURRY SEAL, COATING,
STRIPING AND MARKING OF
PARKING LOT NO. 4**

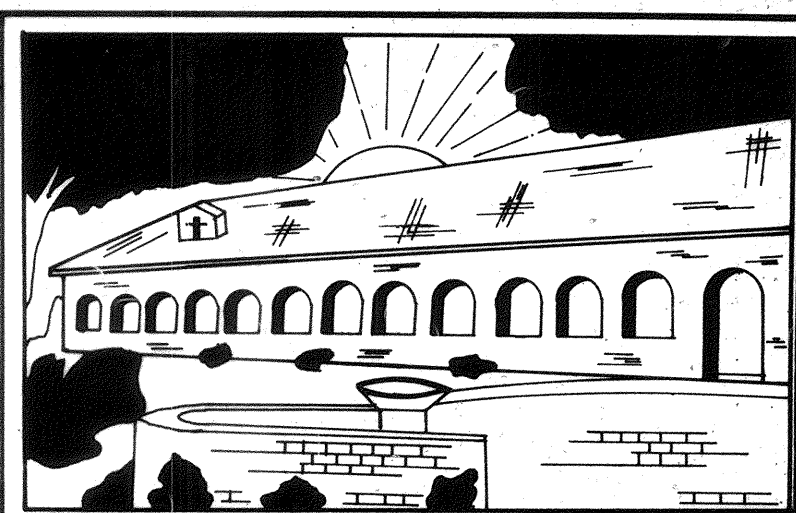

R. A. Navarro
CITY ENGINEER R.C.E. NO. 221328 DATE 4-13-90

R. A. NAVARRO - ASST. CITY ENGINEER

SHEET 3 OF 8





DESIGN
R. A. NAVARRO

DRN.
SAM IBRAHIM

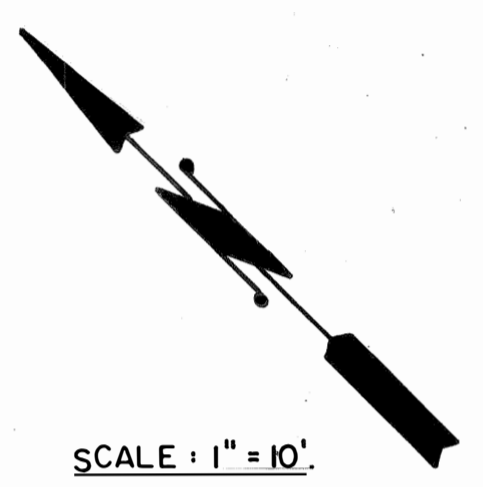
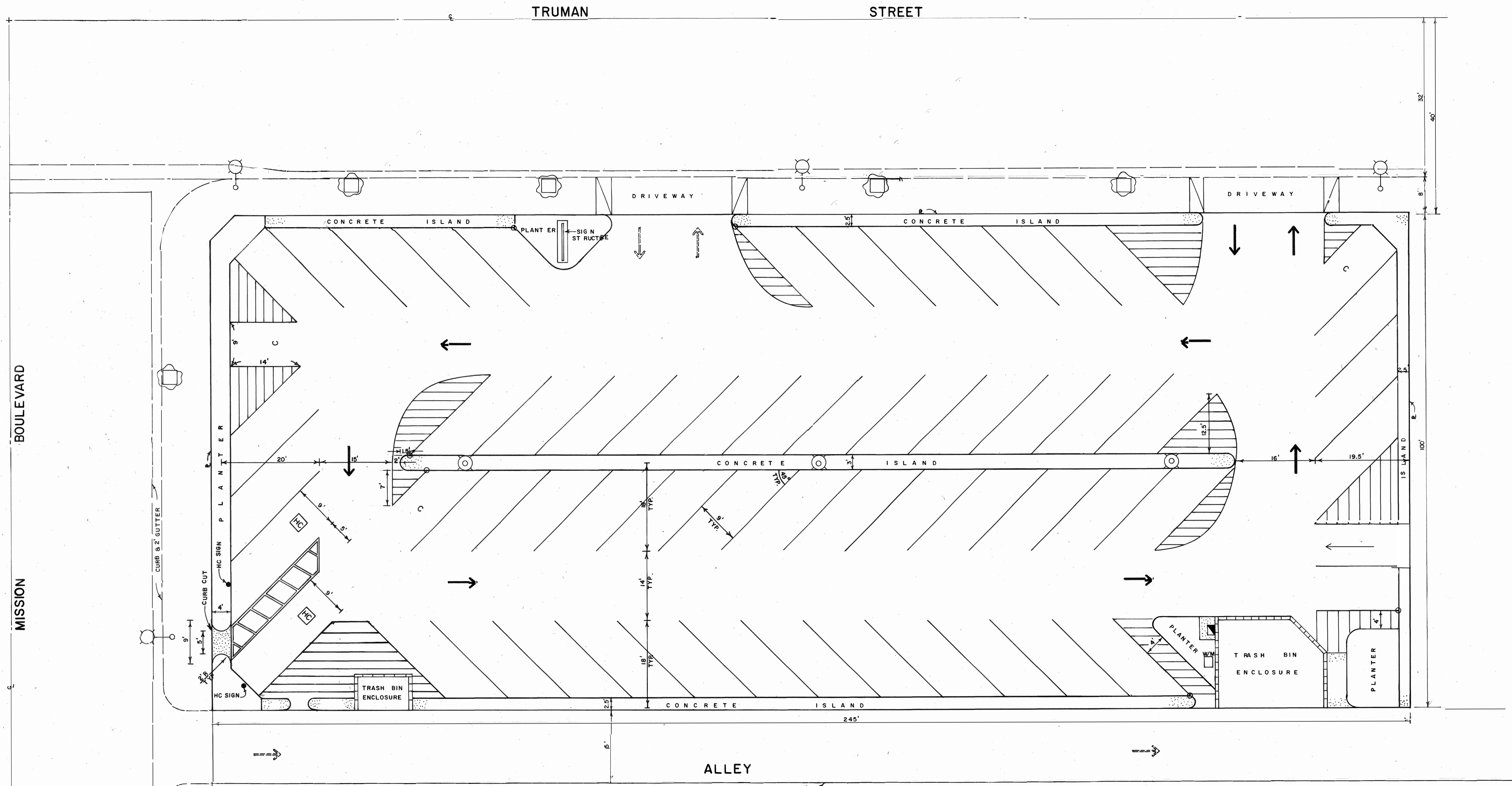
DATE
FEBRUARY, 1990

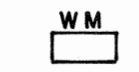
PLAN
MS - 532

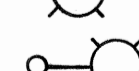

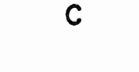
- LEGEND**
-  ELECTRICAL CONTROLLER
 -  WATER METER
 -  PARKING LOT LIGHT
 -  STREET LIGHT
 -  PARKWAY TREE
 -  PARKING STALL FOR COMPACT CAR
 -  CONTROLLING POINT FOR STRIPING

REFERENCE: PLAN NO. P-402 A
JOB NO. 7332

SAN FERNANDO, CALIFORNIA

SLURRY SEAL, COATING,
STRIPING AND MARKING OF
PARKING LOT NO. 5

R.A. Navarro 22132 4-18-90
CITY ENGINEER R.C.E. NO. DATE

R. A. NAVARRO - ASST. CITY ENGINEER SHEET 4 OF 8

DESIGN R. A. NAVARRO	DRN. SAM IBRAHIM	DATE FEBRUARY, 1990	PLAN MS - 532
-------------------------	---------------------	------------------------	------------------

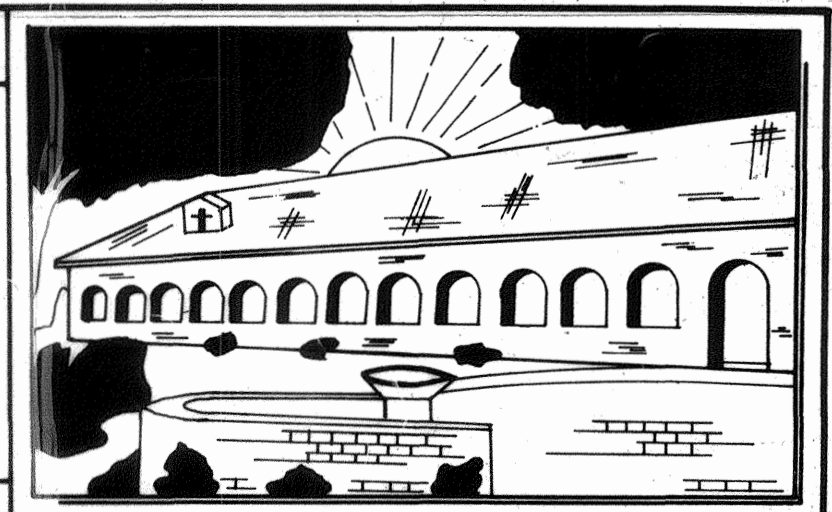

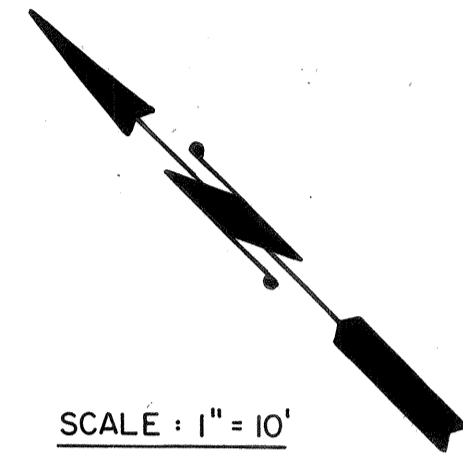

LEGEND

- ELECTRICAL CONTROLLER
- PARKING LOT LIGHT
- PARKWAY TREES
- CONCRETE
- PARKING METER

NOTES

1. THE PARKING LOT IS METERED AND WITH CONCRETE BUMPER (GUARD) STOPS.
2. REMOVE CONCRETE BUMPER STOPS AND SALVAGE TO CITY.

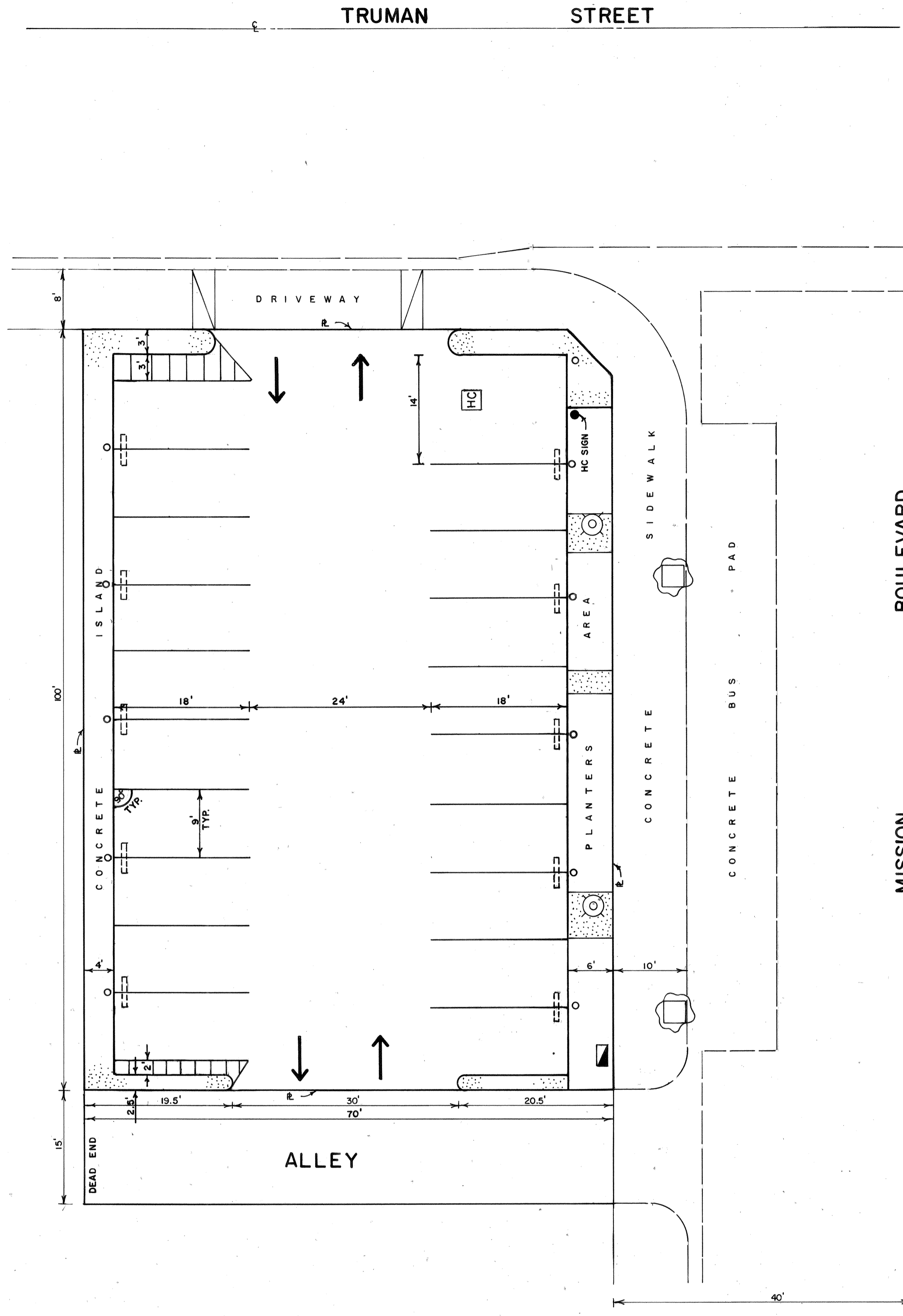

JOB NO. 7332



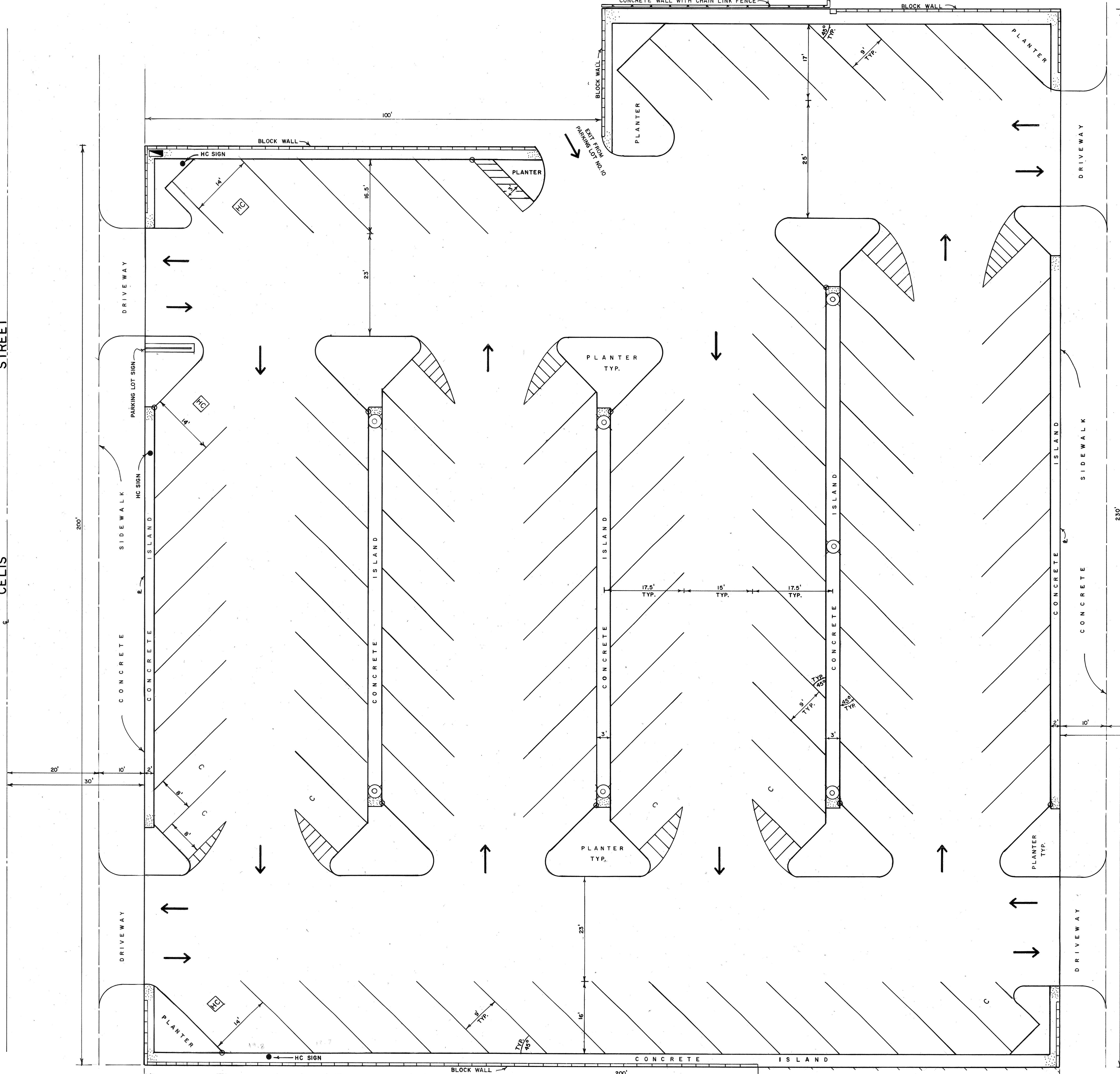

SAN FERNANDO, CALIFORNIA		
SLURRY SEAL, COATING, STRIPING AND MARKING OF		
PARKING LOT NO. 7		
	21328	4-13-90
ENGINEER	R.C.E. NO.	DATE
R. A. NAVARRO - ASST. CITY ENGINEER		
DESIGN	DRN.	DATE
R. A. NAVARRO	SAM IBRAHIM	FEBRUARY, 1990
SHEET 5 OF 8		PLAN
		MS - 532

CELIS STREET

PICO STREET



LEGEND

-  ELECTRICAL CONTROLLER
-  PARKING LOT LIGHT
-  PARKING STALLS FOR COMPACT CARS
-  CONTROLLING POINT FOR STRIPING

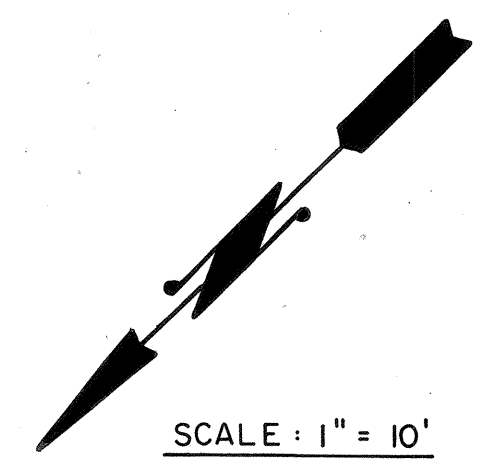

NOTE
 CUT IN CONCRETE SIDEWALK FOR HANDICAP SIGNS SHALL BE AT THE SCORE LINES. CUT IN CONCRETE ISLAND SHALL BE SQUARE (WIDTH OF ISLAND PAVEMENT).

JOB NO. 7332

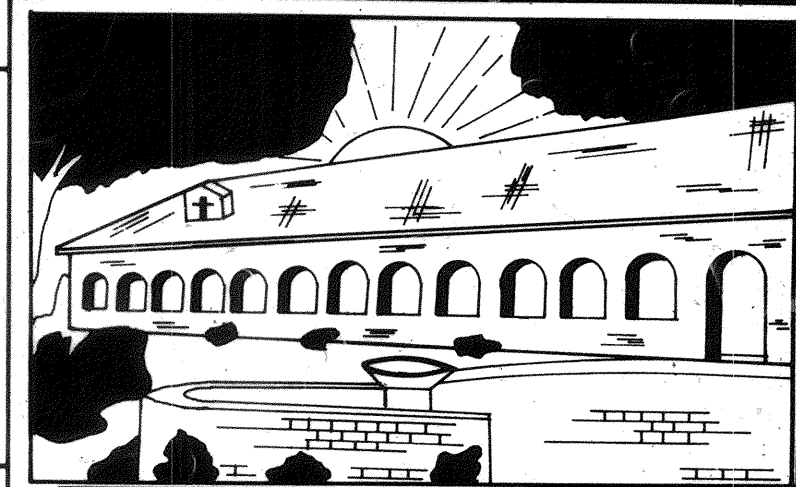
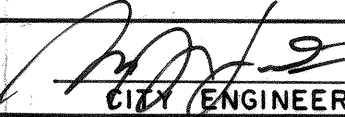
SAN FERNANDO, CALIFORNIA		
SLURRY SEAL, COATING, STRIPING AND MARKING OF		
PARKING LOT NO. 8		
 CITY ENGINEER	21328 R.C.E. NO.	4-18-90 DATE
R. A. NAVARRO - ASST. CITY ENGINEER		SHEET 6 OF 8
DESIGN R. A. NAVARRO	DRN. SAM IBRAHIM	DATE FEBRUARY, 1990
		PLAN MS-532

PARKING LOT NO. 8

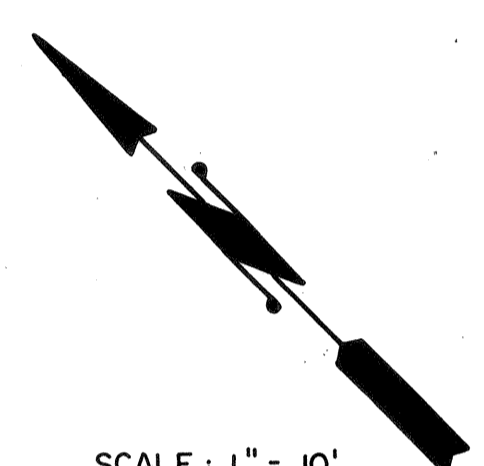
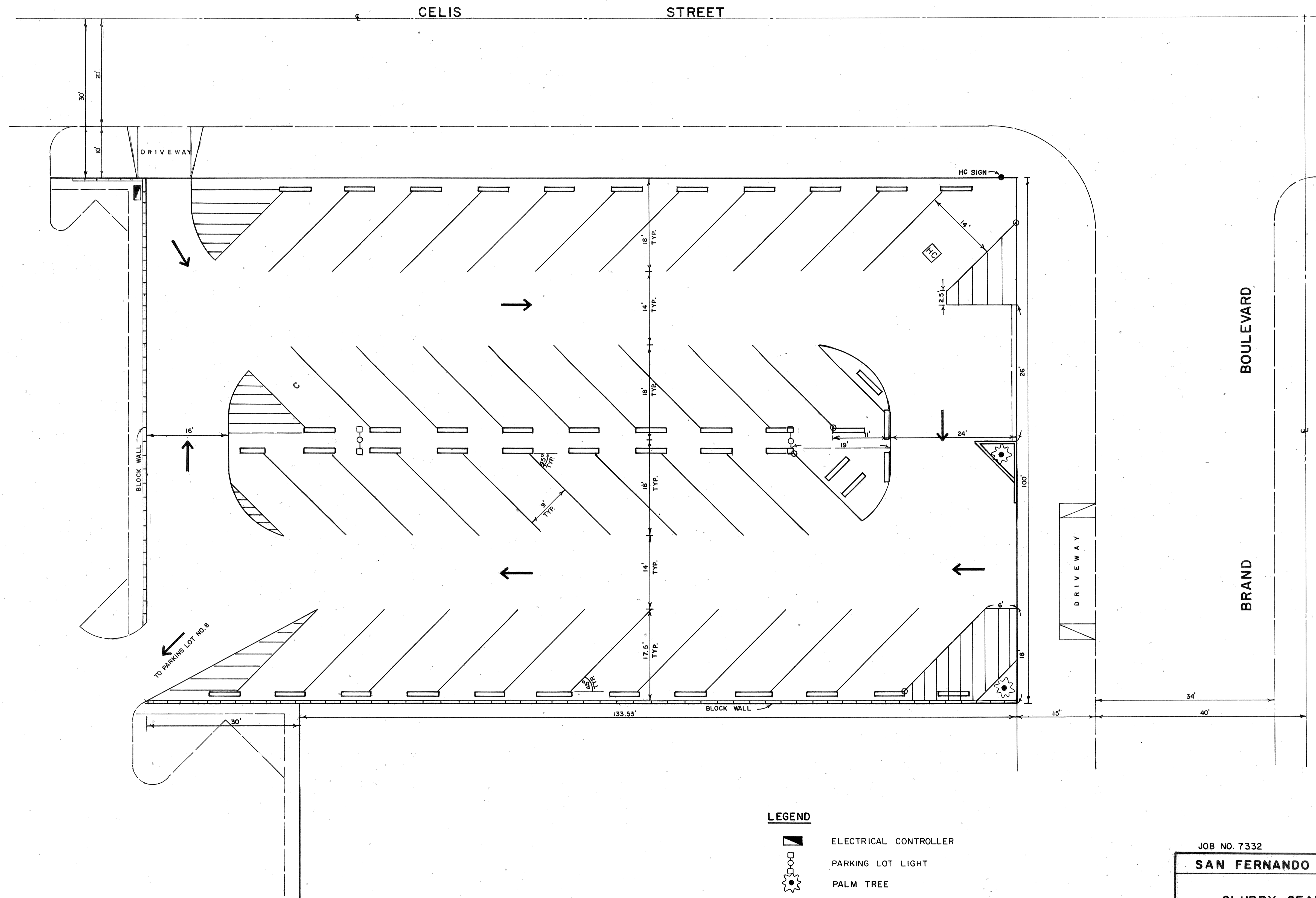

SCALE: 1" = 10'

- NOTES**
1. REMOVE CONCRETE BUMPER STOPS PRIOR TO SLURRY SEAL AND REINSTALL AFTER SLURRY SEAL COATING IS COMPLETED.
 2. CUT IN CONCRETE SIDEWALK FOR HANDICAP SIGNS SHALL BE AT THE SCORE LINES. CUT IN CONCRETE ISLAND SHALL BE SQUARE (WIDTH OF ISLAND PAVEMENT).

LEGEND

- ELECTRICAL CONTROLLER
- PARKING LOT LIGHT
- PALM TREE
- CONCRETE BUMPER (GUARD) STOP
- CONTROLLING POINT FOR STRIPING
- PARKING STALL FOR COMPACT CAR

JOB NO. 7332		
SAN FERNANDO, CALIFORNIA		
SLURRY SEAL, COATING STRIPING AND MARKING OF PARKING LOT NO. 10		
	C21328 R.C.E. NO.	1-13-90 DATE
R. A. NAVARRO - ASST. CITY ENGINEER		SHEET 7 OF 8
DESIGN R. A. NAVARRO	DRN. SAM IBRAHIM	DATE FEBRUARY, 1990
		PLAN MS - 532